

# Educators' Guide for Mathematics

***Grade 1***



West Virginia DEPARTMENT OF  
**EDUCATION**

# Grade One

## Mathematics Instruction

In grade one, students begin to develop the concept of place value by viewing 10 ones as a unit called a ten. This basic but essential idea is the underpinning of the base ten number system. In kindergarten, students learn to count in order, count to find out “how many,” and to add and subtract with small sets of numbers in different situations. They also develop fluency with addition and subtraction within 5. They view teen numbers as composed of a group of 10 ones and more ones. Additionally, kindergarten students identify and describe geometric shapes and create and compose shapes (adapted from Charles A. Dana Center 2012).

In grade one, instructional time focuses on four critical areas: (1) developing understanding of addition, subtraction, and strategies for addition and subtraction within 20; (2) developing understanding of whole number relationships and place value, including grouping of tens and ones; (3) developing understanding of linear measurement and measuring lengths as iterating length units; and (4) reasoning about attributes of and composing and decomposing geometric shapes. Students work toward fluency in addition and subtraction with whole numbers within 10.

## Mathematical Fluency

Students demonstrate fluency of mathematical standards when they exhibit the following:

- » Accuracy – ability to produce an accurate answer
- » Efficiency – ability to choose an appropriate expedient strategy for a specific computation problem
- » Flexibility – ability to use number relationships with ease in computation.

## West Virginia College- and Career-Readiness Standards for Mathematics

The West Virginia College- and Career-Readiness Standards for Mathematics (WVBE Policy 2520.2B) emphasize key content, skills, and practices at each grade level and support three major principles:

- » Instruction is focused on grade level standards.
- » Instruction is attentive to learning across grades and to linking major topics within grades.
- » Instruction develops conceptual understanding, procedural skill and fluency, and application.

Grade level examples of these three major principles are indicated throughout this document.

Cluster headings can be viewed as the most effective way to communicate the focus and coherence of the standards. The instructional focus must be based on the depth of the ideas, the time needed to master the clusters, and their importance to future mathematics or the later demands of preparing for college and careers.

Teachers and administrators alike understand that the standards are not topics to be checked off after being covered in isolated units of instruction; rather, they provide content to be developed throughout the school year through rich instructional experiences presented in a coherent manner. West Virginia College- and Career-Readiness Standards for Mathematics are learning goals for students that must be mastered by the end of the first-grade academic year for students to be prepared for the mathematics content at the grade two level.

### Connecting Mathematical Habits of Mind and Content

The Mathematical Habits of Mind are developed throughout each grade and, together with the content standards, prescribe that students experience mathematics as a useful and logical subject that adds value and meaning to daily interactions in their lives. The Mathematical Habits of Mind represent a picture of what it looks like for students to understand and do mathematics in the classroom. The Mathematical Habits of Mind are the behaviors and dispositions of mathematics and should be integrated into every mathematics lesson for all students and are part of the comprehensive approach to early and elementary learning per *WVBE Policy, 2510, Assuring Quality of Education: Regulations for Education Programs*.

Although the description of the Mathematical Habits of Mind remains the same at all grade levels, the way these standards look as students engage with and master new and more advanced mathematical ideas does change. The following chart presents examples of how the Mathematical Habits of Mind may be integrated into tasks appropriate for students in grade one.

#### Mathematical Habits of Mind—Explanation and Examples for Grade One

| Mathematical Habits of Mind  | Explanation and Examples  |
|--|---|
| <p><b>MHM1</b><br/>Make sense of problems and persevere in solving them.</p> | <p>In first grade, students realize that doing mathematics involves solving problems and discussing how they solved them. Students explain to themselves and others the meaning of a problem and look for ways to solve it. Students may use concrete objects or math drawings to help them conceptualize and solve problems. They may check their thinking by asking themselves, “Does this make sense?” They are willing to try other approaches.</p>   |
| <p><b>MHM2</b><br/>Reason abstractly and quantitatively.</p>                 | <p>Students recognize that a number represents a specific quantity. They connect the quantity to written symbols. Quantitative reasoning entails creating a representation of a problem while attending to the meanings of the quantities.</p> <p>Grade one students make sense of quantities and relationships while solving tasks. They represent situations by decontextualizing tasks into numbers and symbols. For example, “There are 14 children on the playground, and some children go line up. If there are 8 children still playing, how many children lined up?” Students translate the problem into the situation equation <math>14 - \_\_\_ = 8</math>, then into the related equation <math>8 + \_\_\_ = 14</math>, and then solve the task. Students also contextualize situations during the problem-solving process. For example, students refer to the context of the task to determine they need to subtract 8 from 14, because the number of children in line is the total number less the 8 who are still playing. To reinforce students’ reasoning and understanding, teachers might ask, “How do you know” or “What is the relationship of the quantities?” Students might also reason about ways to partition two-dimensional geometric figures into halves and fourths.</p> |

| <b>Mathematical Habits of Mind</b>  | <b>Explanation and Examples</b>  |
|---|--|
| <p><b>MHM3</b><br/>Construct viable arguments and critique the reasoning of others.</p> | <p>Grade one students construct arguments using concrete referents, such as objects, pictures, drawings, and actions. They practice mathematical communication skills as they participate in mathematical discussions involving questions such as “How did you get that?” or “Explain your thinking” and “Why is that true?” They explain their own thinking and listen to the explanations of others. For example, “There are 9 books on the shelf. If you put more books on the shelf and there are now 15 books on the shelf, how many books did you put on the shelf?” Students may use a variety of strategies to solve the task and then share and discuss their problem-solving strategies with their classmates.</p>   |
| <p><b>MHM4</b><br/>Model with mathematics.</p>  | <p>In the early grades, students experiment with representing problem situations in multiple ways, including writing numbers, using words (mathematical language), drawing pictures, using objects, acting out, making a chart or list, or creating equations. Students need opportunities to connect the different representations and explain the connections. They are able to use any of these representations as needed.</p> <p>Grade one students model real-life mathematical situations with an equation and check to make sure equations accurately match the problem context. Students use concrete models and pictorial representations while solving tasks and also write an equation to model problem situations. For example, to solve the problem, “There are 11 bananas on the counter. If you eat 4 bananas, how many are left?”, students could write the equation <math>11 - 4 = 7</math>. Students are encouraged to answer questions such as “What math drawing or diagram could you make and label to represent the problem?” or “What are some ways to represent the quantities?”</p> |
| <p><b>MHM5</b><br/>Use appropriate tools strategically.</p>                             | <p>Students begin to consider the available tools (including estimation) when solving a mathematical problem and decide when tools might be helpful. For instance, grade one students decide it might be best to use colored chips to model an addition problem.</p> <p>Students use tools such as counters, place value (base ten) blocks, hundreds number boards, concrete geometric shapes (e.g., pattern blocks or three-dimensional solids), and virtual representations to support conceptual understanding and mathematical thinking. Students determine which tools are appropriate to use. For example, when solving <math>12 + 8 = \underline{\quad}</math>, students might explain why place-value blocks are appropriate to use to solve the problem. Students are encouraged to answer questions such as “Why was it helpful to use...?”</p>  |
| <p><b>MHM6</b><br/>Attend to precision.</p>   | <p>As young children begin to develop their mathematical communication skills, they try to use clear and precise language in their discussions with others and when they explain their own reasoning.</p> <p>In grade one, students use precise communication, calculation, and measurement skills. Students are able to describe their solution strategies for mathematical tasks using grade level appropriate vocabulary, precise explanations, and mathematical reasoning. When students measure objects iteratively (repetitively), they check to make sure there are no gaps or overlaps. Students regularly check their work to ensure the accuracy and reasonableness of solutions.</p>  |

| <b>Mathematical Habits of Mind</b>  | <b>Explanation and Examples</b>   |
|---|---|
| <p><b>MHM7</b><br/>Look for and make use of structure.</p>                    | <p>Grade one students look for patterns and structures in the number system and other areas of mathematics. While solving addition problems, students begin to recognize the commutative property—for example, <math>7 + 4 = 11</math>, and <math>4 + 7 = 11</math>. While decomposing two-digit numbers, students realize that any two-digit number can be broken up into tens and ones (e.g., <math>35 = 30 + 5</math>, <math>76 = 70 + 6</math>). Grade one students make use of structure when they work with subtraction as an unknown addend problem. For example, <math>13 - 7 = \underline{\quad}</math> can be written as <math>7 + \underline{\quad} = 13</math> and can be thought of as “How much more do I need to add to 7 to get to 13?”</p>   |
| <p><b>MHM8</b><br/>Look for and express regularity in repeated reasoning.</p> | <p>In the early grades, students notice repetitive actions in counting and computation. When children have multiple opportunities to add and subtract 10 and multiples of 10, they notice the pattern and gain a better understanding of place value. Students continually check their work by asking themselves, “Does this make sense?”</p> <p>Grade one students begin to look for regularity in problem structures when solving mathematical tasks. For example, students add three one-digit numbers by using strategies such as “make a ten” or doubles. Students recognize when and how to use strategies to solve similar problems. For example, when evaluating <math>8 + 7 + 2</math>, a student may say, “I know that 8 and 2 equals 10, then I add 7 to get to 17. It helps if I can make a ten out of two numbers when I start.” Students use repeated reasoning while solving a task with multiple correct answers—for example, the problem “There are 12 crayons in the box. Some are red and some are blue. How many of each color could there be?” For this particular problem, students use repeated reasoning to find pairs of numbers that add up to 12 (e.g., the 12 crayons could include 6 of each color [<math>6 + 6 = 12</math>], 7 of one color and 5 of another [<math>7 + 5 = 12</math>], and so on). Students are encouraged to answer questions such as “What is happening in this situation?” or “What predictions or generalizations can this pattern support?”</p> |

*Adapted from Arizona Department of Education (ADE) 2010 and North Carolina Department of Public Instruction (NCDPI) 2013b.*

## Standards-Based Learning at Grade One

The following document is organized by the domains in the West Virginia College- and Career-Readiness Standards for Mathematics and highlights some necessary foundational skills from previous grade levels. It also provides exemplars to explain the content standards, highlight connections to the Mathematical Habits of Mind (**MHM**), and demonstrate the importance of developing conceptual understanding, procedural skill and fluency, and application.

# Domain: Operations and Algebraic Thinking

In kindergarten, students add and subtract numbers within 10 and develop fluency with these operations with whole numbers within 5. A critical area of instruction for students in grade one is to develop an understanding of and strategies for addition and subtraction within 20. Grade one students also become fluent with these operations within 10.

Students in grade one will represent word problems (e.g., using objects, drawings, and equations) and relate strategies to a written method to solve addition and subtraction word problems within 20 (**M.1.1–2**). To solve word problems, students learn to apply various computational methods, as summarized in the table below.

| Methods Used for Solving Single-Digit Addition and Subtraction Problems   |
|---|
| <p><b>Level 1: Direct Modeling by Counting All or Taking Away</b><br/>Represent the situation or numerical problem with groups of objects, a drawing, or fingers. Model the situation by composing two addend groups or decomposing a total group. Solve addition and subtraction word problems in situations of adding to, taking from, putting together, taking apart, and comparing numbers.</p>   |
| <p><b>Level 2: Counting On</b><br/>Embed an addend within the total (the addend is identified as both an addend and as part of the total). Count this total but abbreviate the counting by omitting the count of this addend; instead, begin with the number word of this addend. The count is tracked and monitored in some way (e.g., with fingers, objects, mental images of objects, body motions, or other count words).</p> <p>For addition, the count is stopped when the amount of the remaining addend has been counted. The last number word is the total. For subtraction, the count is stopped when the total occurs in the count. The tracking method indicates the difference (seen as the unknown addend).</p> |
| <p><b>Level 3: Converting to an Easier Equivalent Problem</b><br/>Decompose an addend and compose a part with another addend.</p>   |

*Adapted from UA Progressions Documents 2011a*

Grade one students extend their prior work in three major and interrelated ways:

- » They use Level 2 and Level 3 problem solving methods to extend addition and subtraction problem solving from within 10, to problems within 20.
- » They represent and solve for all unknowns in all three problem types: add to, take from, and put together/take apart.
- » They represent and solve a new problem type: “compare”.

Kindergarten students may use Level 1 methods, and students in grades one and two use Level 2 and Level 3 methods.

Teachers need to be aware of grade one students who only use the counting all strategy (Level 1) to solve addition problems. Teachers need to provide additional support for these students to develop strategies for solving addition and subtraction problems.

## Operations and Algebraic Thinking

### Represent and solve problems involving addition and subtraction.

#### M.1.1

Use addition and subtraction within 20 to solve word problems involving situations of adding to, taking from, putting together, taking apart, and comparing, with unknowns in all positions (e.g., by using objects, drawings, and equations with a symbol for the unknown number to represent the problem).

#### M.1.2

Solve word problems that call for addition of three whole numbers whose sum is less than or equal to 20 (e.g., by using objects, drawings, and equations with a symbol for the unknown number to represent the problem).

In kindergarten, students work with the following types of addition and subtraction situations: **add to** (with result unknown); **take from** (with result unknown); and **put together/take apart** (with total unknown or both addends unknown). Grade one students extend this work to include problems with larger numbers and unknowns in all positions. In grade one, students are also introduced to a new type of addition and subtraction problem—“**compare**” problems.

Students in grade one add and subtract within 20 (**M.1.1–M.1.2**) to solve problems (**MHM1, MHM2, MHM3, MHM4, MHM5, MHM6**). A major goal for grade one students is the use of “**Level 2: Counting On**” methods for addition (find the total) and subtraction (find the unknown addend). Level 2 methods represent a new challenge for students, because when students “count on,” an addend is already embedded in the total to be found; it is the named starting number of the “counting on” sequence. The new problem subtypes with which grade one students work support the development of this “counting on” strategy. In particular, “compare” problems that are solved with tape diagrams can serve as a visual support for this strategy, and they are helpful as students move away from representing all objects in a problem to representing the quantities solely with numbers (*adapted from UA Progressions Documents 2011a*).

Initially, addition and subtraction problems include numbers that are small enough for students to make math drawings to solve problems that include all the objects. Later, students will use other strategies such as counting on, counting back, and/or number lines, to solve problems represented solely with numbers. Students also use the addition symbol (+) to represent “add to” and “put together” situations, the subtraction symbol (-) to represent “take from” and “take apart” situations, and the equal sign (=) to represent a relationship regarding equality between one side of the equation and the other.

## Grade One Addition and Subtraction Problem Types (Excluding “Compare” Problems)

| Type of Problem  | Result Unknown   | Change Unknown   | Start Unknown  |
|------------------|--|--|--|
| <b>Add to</b>    | <p>Chris has 11 toy cars. José gave him 5 more. How many does Chris have now?</p> <p>This problem could be represented by <math>11+5=\square</math>.</p> <p>General Case: <math>A+B=\square</math>.</p>                                      | <p>Bill had 5 toy robots. His mom gave him some more. Now he has 9 robots. How many toy robots did his mom give him?</p> <p>In this problem, the starting quantity is provided (5 robots), a second quantity is added to that amount (some robots), and the result quantity is given (9 robots). This question type is more algebraic and challenging than the “result unknown” problems and can be modeled by a situational equation (<math>5+\square=9</math>), which can be solved by counting on from 5 to 9. [Refer to standard <b>M.1.6</b> for examples of addition and subtraction strategies that students use to solve problems.]</p> <p>General Case: <math>A+\square=C</math>.</p> | <p>Some children were playing on the playground, and 5 more children joined them. Now there are 12 children. How many children were playing in the beginning?</p> <p>This problem can be represented by <math>\square+5=12</math>. The “start unknown” problems are difficult for students to solve because the initial quantity is unknown and therefore cannot be represented. Children need to see both addends as making the total, and then some children can solve this by <math>5+\square=12</math>.</p> <p>General Case: <math>\square+B=C</math>.</p>                           |
| <b>Take from</b> | <p>There were 20 oranges in the bowl. The family ate 5 oranges from the bowl. How many oranges are left in the bowl?</p> <p>This problem can be represented by <math>20-5=\square</math>.</p> <p>General Case: <math>C-B=\square</math>.</p> | <p>Andrea had 8 stickers. She gave some stickers away. Now she has 2 stickers. How many stickers did she give away?</p> <p>This question can be modeled by a situational equation (<math>8-\square=2</math>) or a solution equation (<math>8-2=\square</math>). Both the “take from” and “add to” questions involve actions.</p> <p>General Case: <math>C-\square=A</math>.</p>  | <p>Some children were lining up for lunch in a classroom. 4 children left the room. There were 6 children still waiting in line. How many children were there in the beginning?</p> <p>This problem can be modeled by <math>\square-4=6</math>. Similar to the previous “add to (start unknown)” problem, the “take from” problems with the start unknown require a high level of conceptual understanding. Children need to see both addends as making the total, and then some children can solve this by <math>4+6=\square</math>.</p> <p>General Case: <math>\square-B=A</math>.</p> |



|  | Total Unknown  | Addend Unknown   | Both Addends Unknown <sup>†</sup>   |
|--|--|--|---|
| Put together/<br>Take apart <sup>‡</sup> | There are 6 blue blocks and 7 red blocks in the box. How many blocks are there?                                    | Roger puts 10 apples in a fruit basket. Four (4) are red and the rest are green. How many are green?   | Grandma has 9 flowers. How many can she put in her green vase and how many in her purple vase?  |
|  | <p>This problem can be represented by <math>7+6=\square</math>.</p> <p>General Case: <math>A+B=\square</math>.</p> | <p>There is no direct or implied action. The problem involves a set and its subsets. It can be modeled by <math>10-4=\square</math> or <math>4+\square=10</math>. This type of problem provides students with opportunities to understand addends that are hiding inside a total and also to relate subtraction and an unknown-addend problem.</p> <p>General Case: <math>A+\square=C</math>.</p> <p>General Case: <math>C-A=\square</math>.</p> | <p>Students will name all the combinations of pairs that add to nine:</p> <p><math>9 = 0 + 9</math>      <math>9 = 9 + 0</math><br/> <math>9 = 1 + 8</math>      <math>9 = 8 + 1</math><br/> <math>9 = 2 + 7</math>      <math>9 = 7 + 2</math><br/> <math>9 = 3 + 6</math>      <math>9 = 6 + 3</math><br/> <math>9 = 4 + 5</math>      <math>9 = 5 + 4</math></p> <p>Being systematic while naming the pairs is efficient. Students should notice that the pattern repeats after <math>5 + 4</math> and know that they have named all possible combinations.</p> <p>General Case: <math>C=\square+\square</math>.</p> |

Note: In this table, the “Difference Unknown” section indicates the problem subtypes introduced in kindergarten. Grade one and grade two students work with all problem subtypes. The “Addend Unknown” and “Both Addends Unknown” problems are the most difficult subtypes that students work with in grade one, but students need not master these problems until grade two.

<sup>†</sup>These take-apart situations can be used to show all the decompositions of a given number. The associated equations, which have the total on the left of the equal sign (=), help children understand that the = sign does not always mean makes or results in, but does always mean is the same number as.

<sup>‡</sup>Either addend can be unknown, so there are three variation of these problem situations. “Both Addends Unknown” is a productive extension of this basic situation, especially for small numbers less than or equal to 10.

“Compare” problems are introduced in grade one (see the following table). In a compare situation, two quantities are compared to find “How many more” or “How many less.” One reason “compare” problems are more advanced than the other two major problem types is that in “compare” problems, one of the quantities (the difference) is not present in the situation physically; it must be conceptualized and constructed in a representation by showing the “extra” that, when added to the smaller unknown, makes the total equal to the bigger unknown, or by finding this quantity embedded in the bigger unknown.

## Grade One Addition and Subtraction Problem Types (Excluding “Compare” Problems)

|                | Difference Unknown  | Bigger Unknown  | Smaller Unknown   |
|----------------|---|---|---|
| <b>Compare</b> | <p>Pat has 9 peaches. Lynda has 4 peaches. How many more peaches does Lynda have than Pat?</p> <p>“Compare” problems involve relationships between quantities. Although most adults might use subtraction to solve this type of Compare problem (<math>9-4=\square</math>), students will often solve this problem as an unknown-addend problem (<math>4+\square=9</math>) or by using a “counting up” or matching strategy. In all mathematical problem solving, what matters is the explanation a student gives to relate a representation to a context—not the representation separated from its context.</p> <p>General Case: <math>A+\square=C</math>.<br/>General Case: <math>C-A=\square</math>.</p> | <p><b>“More” version:</b> Theo has 7 action figures. Rosa has 2 more action figures than Theo. How many action figures does Rosa have? This problem can be modeled by <math>7+2=\square</math>.</p> <p><b>“Fewer” version—with misleading language:</b> Lucy has 8 apples. She has 2 fewer apples than Marcus. How many apples does Marcus have?</p> <p>This problem can be modeled as <math>8+2=\square</math>. The misleading word <i>fewer</i> may lead students to choose the wrong operation.</p> <p>General Case: <math>A+B=\square</math>.</p> | <p><b>“Fewer” version:</b> Bill has 8 stamps. Lisa has 2 fewer stamps than Bill. How many stamps does Lisa have?</p> <p>This problem can be modeled as <math>8-2=\square</math>.</p> <p><b>“More” version—with misleading language:</b> David has 7 more bunnies than Keisha. David has 8 bunnies. How many bunnies does Keisha have?</p> <p>This problem can be modeled as <math>8-7=\square</math>. The misleading word <i>more</i> may lead students to choose the wrong operation.</p> <p>General Case: <math>C-B=\square</math>.<br/>General Case: <math>\square+B=C</math>.</p> |

*Note: This table shows that grade one and grade-two students work with all “compare” problem types. The unshaded problems are the most difficult problem types that students work with in grade one, but students need not master these problems until grade two. Adapted from NGA/CCSSO 2010d and UA Progressions Documents 2011a.*

The language of these problems may also be difficult for students. For example, “Julie has 3 more apples than Lucy” states that both (a) Julie has more apples and (b) the difference is 3. Many students “hear” the part of the sentence about who has more, but do not initially hear the part about how many more. Students need experience hearing and saying a separate sentence for each of the two parts to help them comprehend and say the one-sentence form.

---

**Example: Strategies for Solving “Compare” Problems****M.1.1**

---

Abel has 9 balls. Susan has 3 balls. How many more balls does Abel have than Susan?

---

Students use objects to represent the two sets of balls and compare them.



Teachers may also ask the related question, “How many fewer balls does Susan have than Abel?”

---

Students also use comparison bars. Rather than representing the actual objects with manipulatives or drawings, they use the numbers in the problem to represent the quantities.

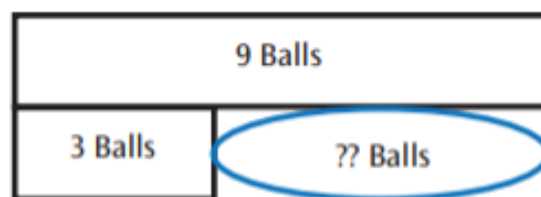

---

Finally, students also work with number-bond diagrams, such as those shown below. They might use drawings that represent quantities or drawings that show only the numbers presented in a problem.

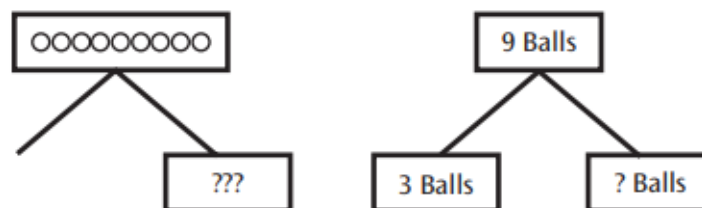

---

Although most adults know to solve “compare” problems with subtraction, students may represent these problems as missing-addend problems (e.g., representing the previous example involving Abel and Susan as  $3 + \square = 9$ ). Student methods such as these should be explored, and the connection between addition and subtraction made explicit (adapted from UA Progressions Documents 2011a).

As mentioned previously, the language and conceptual demands of “compare” problems are challenging for students in grade one. Some students may also have difficulty with the conceptual demands of “start unknown” problems. Grade one students can solve and discuss such problems, but proficiency with these most difficult subtypes is not expected until grade two.

Literature can be incorporated into problem solving with young students. Many literature books include mathematical ideas and concepts. Books that contain problem situations involving addition and subtraction with the numbers 0 through 20 would be appropriate for students (Kansas Association of Teachers of Mathematics [KATM] 2012, 1st Grade Flipbook).

## Instructional Focus

Problems that provide opportunities for students to explain their thinking and use objects and drawings to represent word problems also reinforce the Standards for Mathematical Practice, such as making sense of problems (**MHM1**), reasoning quantitatively to make sense of quantities and their relationships in problems (**MHM2**) and justifying conclusions (**MHM3**).

### Common Misconceptions

- » Some students misunderstand the meaning of the equal sign. The equal sign means has the same value as, but many primary students think the equal sign means the answer is coming up to the right of the equal sign. When students are introduced only to examples of number sentences with the operation to the left of the equal sign and the answer to the right, they overgeneralize the meaning of the equal sign, which creates this misconception. Students should see equations written in multiple ways — for example,  $5 + 7 = 12$  and  $12 = 5 + 7$ . The put together/take apart (with both addends unknown) problems are particularly helpful for eliciting equations such as  $12 = 5 + 7$  (with the sum to the left of the equal sign). Consider this problem: “Robbie puts 12 balls in a basket. Some of the balls are orange and the rest are black. How many are orange and how many are black?” These equations can be introduced in kindergarten with small numbers (e.g.,  $5 = 4 + 1$ ), and they are used throughout grade one.
- » Many students assume key words or phrases in a problem suggest the same operation every time. For example, students might assume the word left always means they need to subtract to find a solution. To help students avoid this misconception, include problems in which key words represent different operations. For example, “Joe took 8 stickers he no longer wanted and gave them to Anna. Now Joe has 11 stickers left. How many stickers did Joe have to begin with?” Facilitate students’ understanding of scenarios represented in word problems. Students analyze word problems (**MHM1, MHM2**) and not rely on key words.

*Adapted from KATM 2012, 1st Grade Flipbook.*

Grade one students solve word problems that call for addition of three whole numbers whose sum is less than or equal to 20 (**M.1.2**). Students can collaborate in small groups to develop problem solving strategies. Students use a variety of strategies and models—such as drawings, words, and equations with symbols for the unknown numbers—to find solutions. Students explain, write, and reflect on their problem-solving strategies (**MHM1, MHM2, MHM3, MHM4, MHM6**). For example, each student may write or draw a problem in which three groups of items (whose sum is within 20) are to be combined. Students might exchange their problems with other students, solve them individually, and then discuss their models and solution strategies. The students work together to solve each problem using a different strategy. The level of difficulty for these problems also may be differentiated by using smaller numbers (up to 10) or larger numbers (up to 20).

## Operations and Algebraic Thinking

### Understand and apply properties of operations and the relationship between addition and subtraction.

#### M.1.3

Apply properties of operations as strategies to add and subtract (e.g., If  $8 + 3 = 11$  is known, then  $3 + 8 = 11$  is also known: Commutative Property of Addition. To add  $2 + 6 + 4$ , the second two numbers can be added to make a ten, so  $2 + 6 + 4 = 2 + 10 = 12$ : Associative Property of Addition).  
Instructional Note: Students need not use formal terms for these properties.

#### M.1.4

Understand subtraction as an unknown-addend problem (e.g., subtract  $10 - 8$  by finding the number that makes 10 when added to 8).

Grade one students build their understanding of the relationship between addition and subtraction. Instruction includes opportunities for students to investigate, identify, and then apply a pattern or structure in mathematics. For example, pose a string of addition and subtraction problems involving the same three numbers chosen from the numbers 0 to 20 (e.g.,  $4 + 6 = 10$  and  $6 + 4 = 10$ ; or  $10 - 6 = 4$  and  $10 - 4 = 6$ ). These are related facts—a set of three numbers that can be expressed with an addition or subtraction equation. Related facts help develop an understanding of the relationship between addition and subtraction and the commutative and associative properties.

Students apply properties of operations as strategies to add and subtract (**M.1.3**). Although it is not necessary for students to learn the names of the properties, students need to understand the important ideas of the following properties:

- **Identity property of addition** (e.g.,  $6 = 6 + 0$ ) — adding 0 to a number results in the same number.
- **Identity property of subtraction** (e.g.,  $9 - 0 = 9$ ) — subtracting 0 from a number results in the same number.
- **Commutative property of addition** (e.g.,  $4 + 5 = 5 + 4$ ) — the order in which you add numbers does not matter.
- **Associative property of addition** (e.g.,  $(3 + 9) + 1 = 3 + (9 + 1) = 3 + 10 = 13$ ) — when adding more than two numbers, it does not matter which numbers are added together first.

---

### Example

**M.1.3**

To show that order does not change the result in the operation of addition, students build a tower of 8 green cubes and 3 yellow cubes, and another tower of 3 yellow cubes and 8 green cubes. Students can also use cubes of 3 different colors to demonstrate that  $(2 + 6) + 4$  is equivalent to  $2 + (6 + 4)$  and then to prove  $2 + (6 + 4) = 2 + 10$ .

---

*Adapted from KATM 2012, 1st Grade Flipbook*

## Focus, Coherence, and Rigor

Students apply the commutative and associative properties as strategies to solve addition problems (**M.1.3**); these properties do not apply to subtraction. They use mathematical tools, such as cubes and counters, and visual models (e.g., drawings and a 100 chart) to model and explain their thinking. Students can share, discuss, and compare their strategies as a class (**MHM2, MHM7, MHM8**).

Students understand subtraction as an unknown-addend problem (**M.1.4**). Word problems such as **put together/take apart** (with addend unknown) afford students a context to see subtraction as the opposite of addition by finding an unknown addend. Understanding subtraction as an unknown-addend addition problem is one of the essential understandings students will need in middle school to extend arithmetic to negative rational numbers (adapted from ADE 2010 and UA Progressions Documents 2011a).

### Common Misconceptions

» Students may assume that the commutative property applies to subtraction. After students have discovered and applied the commutative property of addition, ask them to investigate whether this property works for subtraction. Have students share and discuss their reasoning with each other; guide them to conclude that the commutative property does not apply to subtraction (adapted from KATM 2012, 1st Grade Flipbook). This may be challenging. Students might think they can switch the addends in subtraction equations because of their work with related-fact equations using the commutative property for addition. Although  $10 - 2 = 8$  and  $10 - 8 = 2$  are related equations, they do not constitute an example of the commutative property because the differences are not the same. Students also need to understand that they cannot switch the total and an addend (for example:  $10 - 2$  and  $2 - 10$ ) and get the same difference.

## Add and subtract within 20.

### Understand and apply properties of operations and the relationship between addition and subtraction.

#### M.1.5

Relate counting to addition and subtraction (e.g., by counting on 2 to add 2, by counting backwards 3 to subtract 3).

#### M.1.6

Add and subtract within 20, demonstrating fluency for addition and subtraction within 10 and use strategies such as · counting on; · making ten (e.g.,  $8 + 6 = 8 + 2 + 4 = 10 + 4 = 14$ ); · decomposing a number leading to a ten (e.g.,  $13 - 4 = 13 - 3 - 1 = 10 - 1 = 9$ ); · using the relationship between addition and subtraction (e.g., knowing that  $8 + 4 = 12$ , one knows  $12 - 8 = 4$ ); and · creating equivalent but easier or known sums (e.g., adding  $6 + 7$  by creating the known equivalent  $6 + 6 + 1 = 12 + 1 = 13$ ).

Primary students come to understand addition and subtraction as they connect counting and number sequence to these operations (**M.1.5**). Students connect counting on and counting back to addition and subtraction. For example, students count on (3) from 4 to solve the addition problem  $4 + 3 = 7$ . Similarly, students count back (3) from 7 to solve the subtraction problem  $7 - 3 = 4$ . The “counting all” strategy requires students to count an entire set. The “counting on” and “counting back” strategies occur when students can hold the start number in their head and count on from that number. Students generally have difficulty knowing where to begin their count when counting backward, so it is much better to restate the subtraction as an unknown addend and solve by counting on: “ $7 - 3$  means  $3 + \square = 7$ , so 4, 5, 6, 7 ... I counted on 4 more to get to 7, so 4 is the answer.” Solving subtraction problems by counting on helps to reinforce the concept that subtraction problems are missing-addend problems, which is important for students’ later understanding of operations with rational numbers.

Students will use different strategies to solve problems if given the time and space to do so. It is important that teachers explore the various methods that arise as students work to understand general properties of operations.

---

**Example: Students use different strategies to solve a problem**

**M.1.6**

There are crayons in a box. There are 4 green crayons, 5 blue crayons, and 6 red crayons. How many crayons are in the box? Explain to others how you found your answer.

**Student 1**

I put 4 counters on a 10-frame for the green crayons. Then I put 5 different-colored counters on the 10-frame for the blue crayons. And then I put another 6 color counters out for the red crayons. Only one of the crayons fit, so I had 5 left over. One 10-frame and 5 left over make 15 crayons (**MHM2, MHM3, MHM5**) (**M.1.2**).

**Student 2**

I know that 4 and 6 equal 10, so the green and red equal 10 crayons. Then I added the 5 blue crayons to get 15 total crayons (**MHM2, MHM6**) (**M.1.3**).

**Student 3**

I counted on from 6, first counting on 5 to get 11 and then counting on 4 to get 15. I used my fingers to keep track of the 5 and the 4. But now I see that because 5 and 4 make 9, I could have counted on 6 from 9. So, there were 15 total crayons (**MHM1, MHM2**) (**M.1.6**).

---

Grade one students use various strategies to add and subtract within 20 (**M.1.6**). Students need many opportunities to model operations using various strategies and explain their thinking (**MHM2, MHM7, MHM8**).

**Example:  $8 + 7 = \underline{\quad}$**

**M.1.6**

**Student 1 (Making 10 and decomposing a number)**

I know that 8 plus 2 is 10, so I decomposed (broke up) the 7 into a 2 and a 5. First, I added 8 and 2 to get 10, and then I added the 5 to get 15.

$$8 + 7 = (8 + 2) + 5 = 10 + 5 = 15$$

**Student 2 (Creating an easier problem with known sums)**

I know 8 is  $7 + 1$ . I also know that 7 and 7 equal 14. Then I added 1 more to get 15.

$$8 + 7 = (7 + 7) + 1 = 15$$

**Example:  $14 - 6 = \underline{\quad}$**

**M.1.6**

**Student 1 (Decomposing the number you subtract)**

I know that 14 minus 4 is 10, so I broke up the 6 into a 4 and a 2. 14 minus 4 is 10. Then I take away 2 more to get 8.

$$14 - 6 = (14 - 4) - 2 = 10 - 2 = 8$$

**Student 2 (Relationship between addition and subtraction)**

I know that 6 plus 8 is 14, so that means that 14 minus 6 is 8.  $6 + 8 = 14$ , so  $14 - 6 = 8$ .

If I did not know  $6 + 8 = 14$ , I could start by making a ten:  $6 + 4$  is 10, and 4 more is 14, and 4 plus 4 is 8.

*Adapted from ADE 2010 and Georgia Department of Education (GaDOE) 2011.*

Students begin to develop algebraic understanding when they create equivalent expressions to solve a problem (such as when they write a situation equation and then write a solution equation from that) or use addition or subtraction combinations they know to solve more difficult problems.

## FLUENCY

In the standards for kindergarten through grade six, there are individual content standards that set expectations for fluency in computation (e.g., fluently add and subtract within 10) [M.1.6]. Such standards are culminations of progressions of learning, often spanning several grades, involving conceptual understanding, thoughtful practice, and extra support where necessary. The word fluent is used in the standards to mean “reasonably fast and accurate” and possessing the ability to use certain facts and procedures with enough facility that using such knowledge does not slow down or derail the problem solver as he or she works on more complex problems.

Procedural fluency requires skill in carrying out procedures flexibly, accurately, efficiently, and appropriately. Developing fluency in each grade may involve a mixture of knowing some answers, knowing some answers from patterns, and knowing some answers through the use of strategies.

*Adapted from UA Progressions Documents 2011a.*

Some strategies to help students develop understanding and fluency with addition and subtraction include the use of 10-frames or math drawings, comparison bars, number-bond diagrams and number relationships. The use of visuals (e.g., hundreds charts and base-ten representations) also support fluency and number sense.



Students continue to develop meanings for addition and subtraction as they encounter problem situations in kindergarten through grade two. They expand their ability to represent problems, and they use increasingly sophisticated computation methods to find answers. In each grade, the situations, representations, and methods foster growth from one grade to the next.

## Operations and Algebraic Thinking

### Work with addition and subtraction equations.

#### **M.1.7**

Understand the meaning of the equal sign, and determine if equations involving addition and subtraction are true or false (e.g., Which of the following equations are true and which are false?  $6 = 6$ ,  $7 = 8 - 1$ ,  $5 + 2 = 2 + 5$ ,  $4 + 1 = 5 + 2$ ). Recognize the difference between an expression ( $3 + 5$ ) and an equation ( $3 + 5 = 8$ ).

#### **M.1.8**

Determine the unknown whole number in an addition or subtraction equation relating three whole numbers (e.g., Determine the unknown number that makes the equation true in each of the equations.  $8 + ? = 11$ ,  $5 = ? - 3$ ,  $6 + 6 = ?$ ).

Students need to understand the meaning of the equal sign (**M.1.7**) and know that the quantity on one side of the equal sign must have the same value as on the other side of the equal sign. Interchanging the language of equal to and has the same value as, as well as not equal to and does not have the same value as, will help students grasp the meaning of the equal sign.

To avoid common pitfalls such as the equal sign meaning “to do something” or the equal sign meaning “the answer is,” students are able to:

- express their understanding of the meaning of the equal sign;
- realize that sentences other than  $a + b = c$  are true (e.g.,  $a = a$ ,  $c = a + b$ ,  $a = a + 0$ ,  $a + b = b + a$ );
- know the equal sign represents a relationship between two equal quantities;
- compare expressions without calculating. For example, a student evaluates “ $3 + 4 = 3 + 3 + 2$ ”. She says, “I know this statement is false because there is a 3 on both sides of the equal sign, but the right side has  $3 + 2$ , and that makes 5, which is more than 4. So, the two sides can’t be equal.”

**True/False** Statements for Developing Understanding of the Equal Sign**M.1.7**

|                   |                         |
|-------------------|-------------------------|
| $7 = 8 - 1$       | $9 + 3 = 10$            |
| $8 = 8$           | $5 + 3 = 10 - 2$        |
| $1 + 1 + 3 = 7$   | $3 + 4 + 5 = 3 + 5 + 4$ |
| $4 + 3 = 3 + 4$   | $3 + 4 + 5 = 7 + 5$     |
| $6 - 1 = 1 - 6$   | $13 = 10 + 4$           |
| $12 + 2 - 2 = 12$ | $10 + 9 + 1 = 19$       |
| $5 + 2 = 7 + 1$   | $5 - 2 = 3 - 1$         |

Initially, students develop an understanding of the meaning of equality using models. Students can justify their answers, make conjectures (e.g., if you start with zero and add a number and then subtract that same number, you always get zero), and use estimation to support their understanding of equality (adapted from ADE 2010 and KATM 2012, 1st Grade Flipbook).

# Domain: Number and Operations in Base Ten

In kindergarten, students develop an important foundation for understanding the base ten system: they view “teen” numbers as composed of 10 ones and some more ones. A critical area of instruction in grade one is to extend students’ place value understanding to view 10 ones as a unit called a ten and two-digit numbers as amounts of tens and ones (UA Progressions Documents 2012b).

## Number and Operations in Base Ten

### Extend the counting sequence.

#### M.1.9

Count to 120, starting at any number less than 120. In this range, read and write numerals and represent a number of objects with a written numeral. Skip count to 120 by 2’s. Skip count to 120 by 5’s and 10’s.

Grade one students extend reading and writing numerals beyond 20—to 120 (**M.1.9**). Students use objects, words, and symbols to express their understanding of numbers. For a given numeral, students count out the given number of objects, identify the quantity that each digit represents, and write and read the numeral (**MHM2, MHM7, MHM8**). For example:

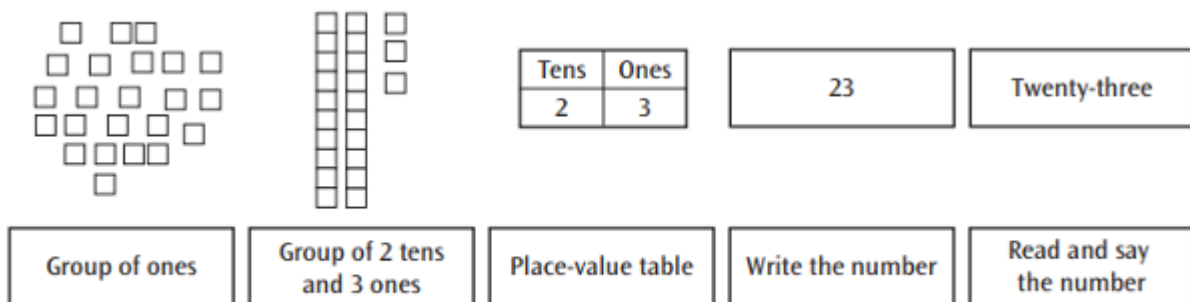

Source: Ohio Department of Education (ODE) 2011.

Seeing different representations can help students develop an understanding of numbers. Posting the number words in the classroom helps students to read and write the words. Extending hundreds charts to 120 and displaying them in the classroom can help students connect place value to the numerals and the words for the numbers 1 to 120. Students may need extra support with decade and century numbers when they orally count to 120. These transitions will be signaled by a 9 and require new rules to generate the next set of numbers. Students need experience counting from different starting points (e.g., start at 83 and count to 120).

### Place-value cards

|               | layered   | separated     |              |      |      |   |               |      |   |              |      |
|---------------|---|---------------|--------------|------|------|---|---------------|------|---|--------------|------|
| front:        | <table border="1"><tr><td><sup>10</sup></td><td><sup>7</sup></td></tr><tr><td>1</td><td>7</td></tr></table> | <sup>10</sup> | <sup>7</sup> | 1    | 7    | <table border="1"><tr><td><sup>10</sup></td></tr><tr><td>10</td></tr></table> | <sup>10</sup> | 10   | <table border="1"><tr><td><sup>7</sup></td></tr><tr><td>7</td></tr></table> | <sup>7</sup> | 7    |
| <sup>10</sup> | <sup>7</sup>  |               |              |      |      |   |               |      |   |              |      |
| 1             | 7   |               |              |      |      |   |               |      |   |              |      |
| <sup>10</sup> |   |               |              |      |      |   |               |      |   |              |      |
| 10            |   |               |              |      |      |   |               |      |   |              |      |
| <sup>7</sup>  |   |               |              |      |      |   |               |      |   |              |      |
| 7             |   |               |              |      |      |   |               |      |   |              |      |
| back:         | <table border="1"><tr><td>●●●●</td><td>●●●●</td></tr><tr><td>●●●●</td><td>●●●●</td></tr></table>            | ●●●●          | ●●●●         | ●●●● | ●●●● | <table border="1"><tr><td>●●●●</td></tr><tr><td>●●●●</td></tr></table>        | ●●●●          | ●●●● | <table border="1"><tr><td>●●●●</td></tr><tr><td>●●●●</td></tr></table>      | ●●●●         | ●●●● |
| ●●●●          | ●●●●  |               |              |      |      |   |               |      |   |              |      |
| ●●●●          | ●●●●  |               |              |      |      |   |               |      |   |              |      |
| ●●●●          |   |               |              |      |      |   |               |      |   |              |      |
| ●●●●          |   |               |              |      |      |   |               |      |   |              |      |
| ●●●●          |   |               |              |      |      |   |               |      |   |              |      |
| ●●●●          |   |               |              |      |      |   |               |      |   |              |      |

Children can use layered place value cards to see the 10 “hiding” inside any teen number. Such decompositions can be connected to numbers represented with objects and math drawings.

Notice the power of the vertical hundreds chart: You can see all 9 of the tens in the numbers 91 to 99.

|     |     |     |
|-----|-----|-----|
| 91  | 101 | 111 |
| 92  | 102 | 112 |
| 93  | 103 | 113 |
| 94  | 104 | 114 |
| 95  | 105 | 115 |
| 96  | 106 | 116 |
| 97  | 107 | 117 |
| 98  | 108 | 118 |
| 99  | 109 | 119 |
| 100 | 110 | 120 |

In the classroom, a list of the numerals from 1 to 120 can be shown in columns of 10 to help highlight the base-ten structure. The numbers 101, . . . , 120 may be especially difficult for children to write.

Source: UA Progressions Documents 2012b.

## Number and Operations in Base Ten

### Understand place value.

#### M.1.10

Understand the two digits of a two-digit number represent amounts of tens and ones. Understand the following as special cases:

- 10 can be thought of as a bundle of ten ones — called a “ten.” (e.g., A group of ten pennies is equivalent to a dime.)
- The numbers from 11 to 19 are composed of a ten and one, two, three, four, five, six, seven, eight or nine ones.
- The numbers 10, 20, 30, 40, 50, 60, 70, 80, 90 refer to one, two, three, four, five, six, seven, eight or nine tens (and 0 ones).

#### M.1.11

Compare and order two two-digit numbers based on meanings of the tens and ones digits, recording the results of comparisons with the symbols  $>$ ,  $=$ , and  $<$ .

Grade one students learn that the two digits of a two-digit number represent amounts of tens and ones (e.g., 67 represents 6 tens and 7 ones) (**M.1.10**).

Understanding the concept of a ten is fundamental to young students’ mathematical development. This is the foundation of the place value system. In kindergarten, students think of a group of 10 cubes as 10 individual cubes. Students understand 10 cubes as a bundle of 10 ones, or a ten (**M.1.10a**). Students can demonstrate this concept by counting 10 objects and “bundling” them into one group of 10 (**MHM2, MHM6, MHM7, MHM8**).

Students count between 10 and 20 objects and can make a bundle of 10 with or without some left over, which can help students write teen numbers (**M.1.10b**). They can continue counting any number of objects up to 99, making bundles of tens with or without leftovers (**M.1.10c**). For example, a student represents the number 14 as one bundle (one group of 10) with four left over.

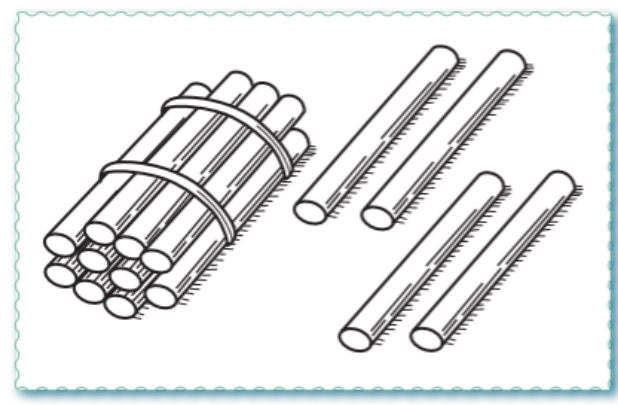

Students can also use models to express larger numbers as bundles of tens and 0 ones or some leftover ones. Students explain their thinking in different ways. For example:

**Teacher:** For the number 42, do you have enough to make 4 tens? Would you have any left? If so, how many would you have left?

**Student 1:** I filled 4 10-frames to make 4 tens and had 2 counters left over. I had enough to make 4 tens with some left over. The number 42 has 4 tens and 2 ones.

**Student 2:** I counted out 42 place value cubes. I traded each group of 10 cubes for a 10-rod (stick). I now have 4 10-rods and 2 cubes left over. So, the number 42 has 4 tens and 2 ones (adapted from ADE 2010).

### Common Misconception

» Students learn to read 53 as *fifty-three* as well as 5 tens and 3 ones. However, some number words require extra attention at grade one because of their irregularities. Students learn that the decade words (*e.g., twenty, thirty, forty, and so on*) indicate 2 tens, 3 tens, 4 tens, and so on. They also realize many decade number words sound much like teen number words. For example, *fourteen* and *forty* sound similar, as do *fifteen* and *fifty*, and so on to *nineteen* and *ninety*. Students learn that the number words from 13 to 19 give the number of ones before the number of tens. Students also frequently make counting errors such as “*twenty-nine, twenty- ten, twenty-eleven, twenty-twelve*” (UA Progressions Documents 2012b). Because of these complexities, it can be helpful for students to use regular tens words as well as English words — for example, “The number 53 is 5 tens, 3 ones, and also fifty-three.”

Grade one students use base ten understanding to recognize that the digit in the tens place is more important than the digit in the ones place for determining the size of a two-digit number (**M.1.11**). Students use models that represent two sets of numbers to compare numbers. Students attend to the number of tens and then, if necessary, to the number of ones. Students may also use math drawings of tens and ones and spoken or written words to compare two numbers. Comparative language includes but is not limited to more than, less than, greater than, most, greatest, least, same as, equal to, and not equal to (**MHM2, MHM6, MHM7 MHM8**) [adapted from ADE 2010].

## Number and Operations in Base Ten

### Use place value understanding and properties of operations to add and subtract.

#### **M.1.12**

Add within 100, including adding a two-digit number and a one-digit number and adding a two-digit number and a multiple of 10, using concrete models or drawings and strategies based on place value, properties of operations and/or the relationship between addition and subtraction. Relate the strategy to a written method and explain the reasoning used. Understand that in adding two-digit numbers, one adds tens and tens, ones and ones, and sometimes it is necessary to compose a ten.

#### **M.1.13**

Given a two-digit number, mentally find 10 more or 10 less than the number, without having to count and explain the reasoning used.

#### **M.1.14**

Subtract multiples of 10 in the range 10-90 from multiples of 10 in the range 10-90 (positive or zero differences) using concrete models or drawings and strategies based on place value, properties of operations and/or the relationship between addition and subtraction. Relate the strategy to a written method and explain the reasoning used.

Students develop understandings and strategies to add within 100 using visual models to support understanding (**M.1.12**). In grade one, students focus on discussing and using efficient, accurate, and generalizable methods to add within 100, and they subtract multiples of 10. Students might also use strategies they invent that are not generalizable.



## Instructional Focus

Grade one students develop understanding of addition and subtraction within 20 using various strategies (**M.1.6**), and they generalize their methods to add within 100 using concrete models and drawings (**M.1.12**). Reasoning about strategies and selecting appropriate strategies are critical to developing conceptual understanding of addition and subtraction in all situations (**MHM1, MHM2, MHM3**) [adapted from Charles A. Dana Center 2012].

Students are exposed to problems that are in and out of context and presented in horizontal and vertical forms. Students solve problems using language associated with proper place value, and they explain and justify their mathematical thinking (**MHM2, MHM6, MHM7, MHM8**).

Students use various strategies and models for addition. Students relate the strategy to a written method and explain the reasoning used (**MHM2, MHM7, MHM8**).

1. Solve  $43 + 36$ . Students may total the tens and then the ones. Place value blocks or other counters support understanding of how to record the written method:

|   |   |  |
|---|---|--|
| 43  | 36  | $43 + 36 = (40 + 30) + (3 + 6) = 70 + 9 = 79$                                      |
|  |  |  |

Students circle like units in the drawings and represent the results numerically.

2. Find the sum.

$$\begin{array}{r} 28 \\ + 34 \\ \hline \end{array}$$



Student thinks: “Adding the tens gives me 2 tens plus 3 tens, which is 5 tens. Counting the ones, I get 10 plus 2 more. Finally, 5 tens plus 1 more ten is 6 tens, or 60, and 2 more makes 62.”

3. Add  $45 + 18$ .

Student thinks: “Four (4) tens and 1 ten is 5 tens, which is 50. To add the ones, I can make a ten by thinking of 5 as  $3 + 2$ , then the 2 combines with the 8 to make 1 ten. So now I have 6 tens altogether, or 60, and 3 ones left — so the total is 63.”

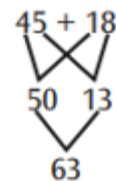

4. Add  $29 + 14$ .

Student thinks: “Since 29 is 1 away from 30, I’ll just think of it as 30. Since  $30 + 14 = 44$ , I know that the answer is 1 too many, so the answer is 43.”

*Adapted from ADE 2010.*

Grade one students engage in mental calculations, such as mentally finding 10 more or 10 less than a given two-digit number without counting by ones (**M.1.13**). Drawings and place value cards can illustrate connections between place value and written numbers. Prior use of models (such as connecting cubes, base ten blocks, and hundreds charts) helps facilitate this understanding. It also helps students see the pattern involved when adding or subtracting 10. For example:

- 10 more than 43 is 53 because 53 is 1 more ten than 43.
- 10 less than 43 is 33 because 33 is 1 ten less than 43.

Students may use interactive or electronic versions of models (base-ten blocks, hundreds charts, and so forth) to develop conceptual understanding (adapted from ADE 2010).

Students need opportunities to represent numbers that are multiples of 10 (e.g., 90) with models or drawings and to subtract multiples of 10 (e.g., 20) using these representations or strategies based on place value (**M.1.13**). These opportunities help develop fluency with addition and subtraction facts and reinforce counting on and counting back by tens. As with single-digit numbers, counting back is difficult — so initially, forward methods of counting on by tens are emphasized rather than counting back.



# Domain: Measurement and Data

A critical area of instruction for students is to develop an understanding of linear measurement and that lengths are measured by iterating length units.

## Measurement and Data

### Measure lengths indirectly and by iterating length units.

#### M.1.15

Order three objects by length and compare the lengths of two objects indirectly by using a third object.

#### M.1.16

Express the length of an object as a whole number of length units, by laying multiple copies of a shorter object (the length unit) end to end; understand that the length measurement of an object is the number of same-size length units that span it with no gaps or overlaps. Instructional Note: Limit to contexts where the object being measured is spanned by a whole number of length units with no gaps or overlaps.

In grade one, students order three objects by length and compare the lengths of two objects indirectly by using a third object (**M.1.15**). Students indirectly compare the lengths of two objects by comparing each to a benchmark object of intermediate length. This concept is referred to as transitivity.

To compare objects, students learn that length is measured from one endpoint to another endpoint. They measure objects to determine which of two objects is longer, by physically aligning the objects. Based on length, students might describe objects as taller, shorter, longer, or higher. If students use less precise words such as bigger or smaller to describe a comparison, they are to be encouraged to further explain what they mean (**MHM6, MHM7**). If objects have more than one measurable length, students also need to identify the length(s) they are measuring. For example, both the length and the width of an object are measurements of lengths.

---

### Examples: Comparing Lengths

**M.1.15**

**Direct Comparisons.** Students can place three items in order, according to length:

- Three students are ordered by height.
- Pencils, crayons, or markers are ordered by length.
- Towers built with cubes are ordered from shortest to tallest.
- Three students draw line segments and then order the segments from shortest to longest.

---

**Indirect Comparisons.** Students make clay “snakes.” Given a tower of cubes, each student compares his or her snake to the tower. Then students make statements such as, “My snake is longer than the cube tower, and your snake is shorter than the cube tower. So, my snake is longer than your snake.”

---

*Adapted from ADE 2010.*

Students gain their first experience with measuring length as the iteration of a smaller, uniform length called a length unit (**M.1.16**). Students learn that measuring the length of an object in this way requires placing length units (manipulatives of the same size) end to end without gaps or overlaps, and then counting the number of units to determine the length. The University of Arizona’s Geometric Measurement Progression recommends beginning with actual standard units (e.g., 1-inch cubes or centimeter cubes, referred to as length units) to measure length (UA Progressions Documents 2012c). In order to fully understand the subtlety of using non-standard units, students need to understand relationships between units of measure, a concept that will appear in the curriculum in later grades.

Standard **M.1.16** limits measurement to whole numbers of length, though not all objects will measure to an exact whole unit. Students will need to adjust their answers because of this. For example, if a pencil actually measures between 6 and 7 centimeter cubes long, the students could state the pencil is “about [6 or 7] centimeter cubes long”; they would choose the closer of the two numbers. As students measure objects (M.1.15–16), they also reinforce counting skills and understandings that are part of the major work at grade one in the Number and Operations in Base Ten domain.

## Measurement and Data

### Tell and write time.

#### **M.1.17**

Tell and write time in hours and half-hours using analog and digital clocks.

#### **M.1.18**

Identify the value of coins and use dimes and pennies to model the relationship between money and place value (e.g., exchange 10 pennies for 1 dime or exchange 10 dimes for 1 dollar).

Grade one students understand several concepts related to telling time (**M.1.17**), such as:

- Within a day, the hour hand goes around a clock twice (the hand moves only in one direction). A day starts with both hands of the clock pointing up.
- When the hour hand of a clock points exactly to a number, the time is exactly on the hour.
- Time on the hour is written in the same manner as it appears on a digital clock.
- The hour hand on a clock moves as time passes, so when it is halfway between two numbers, it is at the half hour.
- There are 60 minutes in one hour, so when the hour hand is halfway between two hours, 30 minutes have passed.
- A half-hour is indicated in written form by using “30” after the colon.

Students need experiences exploring how to tell time in half hours and hours. For example, the clock at the left in the following illustration shows that the time is 8:30. The hour hand is between the 8 and 9, but the hour is 8 since it is not yet on the 9.

---

**Examples: Telling Time****M.1.17**

“The hour hand is halfway between 8 o’clock and 9 o’clock. It is 8:30.”



“It is 4 o’clock because the hour hand points to 4.”



---

The idea that 30 minutes is “halfway” is a difficult concept for students because they have to choose the hour that has passed. Understanding that two 30s make 60 is easy if students make drawings of tens or think about 3 tens and 6 tens. Students can also explore the concept of half on a clock when they work on standard **M.1.21**, finding half of a circle (adapted from ADE 2010; KATM 2012, 1st Grade Flipbook; and NCDPI 2013b).

Grade one students understand several concepts related to counting money (**M.1.18**), such as identifying the value of pennies and dimes by looking at a picture of a single or group of coins. Model coin value relationships based on place value (**M.1.10a**). Students will answer:

| Type of Problem  | Result Unknown   | Change Unknown   | Start Unknown  |
|------------------|--|--|--|
| <b>Add to</b>    | <p>Example 1:<br/>Sally has 2 dimes, she finds 3 more dimes. How much money does Sally have in all?</p> <p>General Case: <math>A+B=C</math></p> <p>Example 2:<br/>Bob has 5 pennies and 1 dime. How much money does Bob have in total? (<b>M.1.10b</b>).</p> <p>General Case: <math>A+B(10)=C</math></p> <p>Example 3:<br/>(By looking at a picture)<br/>How much money does peter have in his piggy bank?</p> <p>General Case: <math>A+B=C</math></p> | <p>Example 1:<br/>Mary has 11 cents, she finds more pennies on the floor. She now has 17 cents. How much money did she find?</p> <p>General Case: <math>11 + \square = 17</math></p> <p>Example 2:<br/>Use skip counting students have learned to determine (<b>M.1.9</b>)<br/>How many dimes will it take to make one dollar?</p> <p>General Case: (skip-count)<br/><math>A+B+C\dots=100</math></p> | <p>This relates to the concepts in <b>M.1.12</b> and <b>M.1.14</b>. Students will need to understand that they can add/subtract groups of 1's, or a group(s) of 10 and 1's to identify smaller/larger numbers.</p> <p>Example 1:<br/>How many pennies do I need to add to 2 cents to have 8 cents in all?</p> <p>General Case: <math>2 + \square = 8</math></p> <p>Example 2:<br/>How many dimes are equivalent to one dollar? (<b>M.1.12</b> and <b>M.1.14</b>)</p> <p>General Case: <math>\square = 100</math></p> <p>Example 3: (understanding place/coin values)<br/>How many pennies are equivalent to a dime?</p> <p>General Case: <math>\square = 10</math></p> |
| <b>Take from</b> | <p>Use base 10 concepts to create student connections that 1 dime can be divided into 10 pennies without changing value.</p> <p>Example:<br/>If I have 10 cents and spend 4 cents, How much money do I have left?</p> <p>General Case: <math>10-4= \square</math></p>  | <p>Use skip counting skills that students have learned to demonstrate understanding of place value and counting back (<b>M.1.9</b>).</p> <p>Example:<br/>Mario has 7 dimes, he spends 4 dimes at the store. How many dimes (Or, how much money) does Mario have left?</p> <p>General Case: <math>7(10)-4(10)= \square</math></p>   | <p>Help students understand 1:10 correspondence with pennies and pennies dimes.</p> <p>Example:<br/>How many dimes (or pennies) do I need to pay for a toy that costs 20 cents?</p> <p>General Case:<br/>Dimes: <math>A+A=20</math><br/>Or <math>A+A+A\dots=20</math></p>  |

## Measurement and Data

### Represent and interpret data.

#### M.1.19

Organize, represent, interpret data with up to three categories; ask and answer questions about the total number of data points, how many in each category and how many more or less are in one category than in another.

Students can use graphs and charts to organize and represent data (**M.1.19**) about things in their lives (e.g., favorite colors, pets, shoe types, and so on).

### Examples: Telling Time

M.1.17

#### Tally Chart

| Shoes We Wear   |       |       |
|---|-------|-------|
| Shoes   | Tally | Total |
|  |       | 5     |
|  |       | 3     |
|  |       | 4     |

#### Picture Chart

| Shoes We Wear   |   |  |   |   |   |
|---|---|--|---|---|---|
|  |  |  |  |  |  |
|  |  |  |  |   |   |
|  |  |  |  |  |   |

Charts may be constructed by groups of students as well as by individual students. These activities will help prepare students for work in grade two when they draw picture graphs and bar graphs (adapted from ADE 2010; GaDOE 2011; and KATM 2012, 1st Grade Flipbook).

When students collect, represent, and interpret data, they reinforce number sense and counting skills. When students ask and answer questions about information in charts or graphs, they sort and compare data. Students use addition and subtraction and comparative language and symbols to interpret graphs and charts (**MHM2, MHM3, MHM4, MHM5, MHM6**).

### Focus, Coherence, and Rigor

When working in the cluster “Represent and interpret data,” students organize, represent, and interpret data with up to three categories (**M.1.19**). This work can also connect to student work with geometric shapes (**M.1.20**) as students collect and sort different shapes and pose and answer related questions—such as, How many triangles are in the collection? How many rectangles are there? How many triangles and rectangles are there? Which category has the most items? How many more? Which category has the least? How many less? Students’ work with data also supports work in the cluster “Represent and solve problems involving addition and subtraction” as students solve problems involving addition and subtraction with three whole numbers (**M.1.1–M.1.2**).

# Domain: Geometry

In grade one, a critical area of instruction is for students to reason about attributes of geometric shapes and about composing and decomposing these shapes.

## Geometry

### Reason with shapes and their attributes.

#### M.1.20

Distinguish between defining attributes (e.g., triangles are closed and three-sided) versus non-defining attributes (e.g., color, orientation, and/or overall size); build and draw shapes to possess defining attributes.

#### M.1.21

Compose two-dimensional shapes (rectangles, squares, trapezoids, triangles, half-circles, and quarter-circles) or three-dimensional shapes (cubes, right rectangular prisms, right circular cones, and right circular cylinders) to create a composite shape and compose new shapes from the composite shape. Instructional Note: Students do not need to learn formal names such as, “right rectangular prism.”

#### M.1.22

Partition circles and rectangles into two and four equal shares, describe the shares using the words halves, fourths and quarters and use the phrases half of, fourth of and quarter of. Describe the whole as two of, or four of the shares and understand for these examples that decomposing into more equal shares creates smaller shares.

#### M.1.23

Create a recognizable pattern following a given rule, using colors, shapes, sizes, and sounds.

Grade one students describe and classify shapes by geometric attributes, and they explain why a shape belongs to a given category (e.g., squares, triangles, circles, rectangles, rhombuses, hexagons, and trapezoids). Students differentiate between defining attributes (e.g., “hexagons have six straight sides”) and non-defining attributes such as color, overall size, and orientation (**M.1.19**) (**MHM1, MHM3, MHM4, MHM7**) [adapted from UA Progressions Documents 2012c].

An *attribute* refers to any characteristic of a shape. Students learn to use attribute language to describe two-dimensional shapes (e.g., number of sides, number of vertices/points, straight sides, closed figures). A student might describe a triangle as “right side up” or “red,” but students learn these are not defining attributes because they are not relevant to whether a shape is a triangle or not.

---

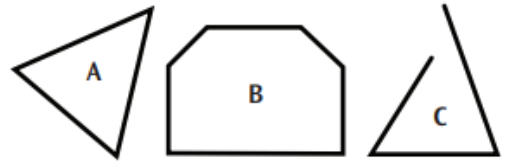
**Examples: Comparing Lengths****M.1.15****Teacher:** “Which figure is a triangle? How do you know?”**Student:** “I know that shape A has three sides and the shape is closed up, so it is a triangle. Shape B has too many sides, and shape C has an opening, so it’s not closed.”**Teacher:** “Are both figures presented here squares? Explain how you know.”**Student:** “I know that a square has right angles and 4 sides, and that each side has the same length. Even though figure E has a point facing down, it is still a square.”

---

Students are exposed to both regular and irregular shapes. In grade one, students use attribute language to describe why the following shapes are not triangles.



Students need opportunities to use appropriate language to describe a given three-dimensional shape (e.g., number of faces, number of vertices/points, and number of edges). For example, a cylinder is a three-dimensional shape that has two circular faces connected by a curved surface (which is not considered a face), but a student might say, “It looks like a can.” Teachers can support learning by defining and using appropriate mathematical terms.

Students need opportunities to compare and contrast two- and three-dimensional figures using defining attributes. The following examples were adapted from ADE 2010:

- Students find two things that are the same and two things that are different between a rectangle and a cube.
- Given a circle and a sphere, students identify the sphere as three-dimensional and both shapes as round.

The ability to describe, use, and visualize the effect of composing and decomposing shapes is an important mathematical skill (**M.1.21**). It is not only relevant to geometry, but also to children’s ability to compose and decompose numbers.

Students may use pattern blocks, plastic shapes, tangrams, or computer environments to make new shapes. Teachers can provide students with cutouts of shapes and ask them to combine the cutouts to make a particular shape. Composing with squares and rectangles and with pairs of right triangles that make squares and rectangles is especially important for future geometric thinking.

Students need experiences with different-sized circles and rectangles to recognize that when they cut something into two equal pieces, each piece will equal one half of its original whole (**M.1.22**). Children recognize that the halves of two different wholes are not necessarily the same size. They also reason that decomposing equal shares into more equal shares results in smaller equal shares.

## Instructional Focus

As grade one students partition circles and rectangles into two and four equal shares and use related language (halves, fourths and quarters (**M.1.22**), they build understanding of part-whole relationships and are introduced to fractional language. Fraction notation will first be introduced in grade three.

### Example: Recognizing and Creating Patterns.

**M.1.23 (MHM4, MHM7)**

#### Example 1: Traditional Shapes or objects

When presented with standardized objects such as colors, shapes, or size variations, students will be able to identify patterns and construct new patterns based on a provided rule.

Ex: ABAB= red, blue, red, blue

#### Example 2: Non-standard objects

When students are given a selection of materials. The students will be able to continue a modeled pattern.

ex. AABAAB= rock, rock, stick, rock, rock, stick

#### Example 3: Auditory Models

Students will be able to recognize and repeat a demonstrated auditory pattern.  
Ex. clap- clap- snap.  
Students will be able to construct their own sound pattern.

Ex: stomp-clap-clap.

## Essential Learning for the Next Grade

In kindergarten through grade five, the focus is on the addition, subtraction, multiplication, and division of whole numbers, fractions, and decimals, with a balance of concepts, skills, and problem solving. Arithmetic is viewed as an important set of skills and also as a thinking subject that, done thoughtfully, prepares students for algebra. Measurement and geometry develop alongside number and operations and are tied specifically to arithmetic along the way.

In kindergarten through grade two, students focus on addition and subtraction and measurement using whole numbers. To be prepared for grade two mathematics, students should be able to demonstrate that they have acquired particular mathematical concepts and procedural skills by the end of grade one and have met the fluency expectations for the grade. For students, the expected fluencies are to add and subtract within 10 (**M.1.6**). These fluencies and the conceptual understandings that support them are foundational for work in later grades.

It is particularly important for students in grade one to attain the concepts, skills, and understandings necessary to:

- » represent and solve problems involving addition and subtraction (**M.1.1–M.1.2**)
- » understand and apply properties of operations and the relationship between addition and subtraction (**M.1.3–M.1.4**)
- » add and subtract within 20 (**M.1.5–M.1.6**)
- » work with addition and subtraction equations (**M.1.7–8**)
- » extend the counting sequence (**M.1.9**)
- » understand place value and use place-value understanding and properties of operations to add and subtract (**M.1.10–M.1.14**)
- » measure lengths indirectly and by iterating length units (**M.1.15–M.1.16**).



## Place Value

By the end of grade one, students are expected to count to 120 (starting from any number), compare whole numbers (at least to 100), and read and write numerals in the same range. Students need to think of whole numbers between 10 and 100 in terms of tens and ones (especially recognizing the numbers 11 to 19 as composed of a ten and some ones). Counting to 120 and reading and representing these numbers with numerals will prepare students to count, read, and write numbers within 1000 in grade two.

## Addition and Subtraction

By the end of grade one, students are expected to add and subtract within 20 and demonstrate fluency with these operations within 10 (**M.1.6**). Students can represent and solve word problems involving add-to, take-from, put-together, take-apart, and compare situations, including addend-unknown situations. They know how to apply properties of addition (associative and commutative) and strategies based on these properties (e.g., “making tens”) to solve addition and subtraction problems. Students use a variety of methods to add within 100, subtract multiples of 10 (using various strategies), and mentally find 10 more or 10 less without counting. Students understand how to solve addition and subtraction equations.

Addition and subtraction are major instructional foci for kindergarten through grade two. Students who have met the standards for addition and subtraction will be prepared to meet the grade two standards of adding and subtracting within 1000 (using concrete models, drawings, and strategies); fluently adding and subtracting within 100 (using various strategies) and within 20 (using mental strategies); and knowing from memory all sums of two one-digit numbers.

## Measurement of Lengths

By the end of grade one, students are expected to order three objects by length (using non-standard units). Students indirectly measure objects, comparing the lengths of two objects by using a third object as a measuring tool. Mastering measurement standards will prepare students to measure and estimate lengths (in standard units) as required in grade two.





Michele L. Blatt  
West Virginia Superintendent of Schools

 /WVEducation  @wveducation

[wvde.us](http://wvde.us)