



SOURCE BOOK

2010



**WEST VIRGINIA BOARD OF EDUCATION
2010-2011**

Priscilla M. Haden, President
Jenny N. Phillips, Vice President
Robert W. Dunlevy, Secretary

Michael I. Green, Member
Burma Hatfield, Member
Lowell E. Johnson, Member
L. Wade Linger Jr., Member
Gayle C. Manchin, Member
William M. White, Member

Brian E. Noland, Ex Officio
Chancellor
West Virginia Higher Education Policy Commission

James L. Skidmore, Ex Officio
Chancellor
West Virginia Council for Community and Technical College Education

Jorea M. Marple, Ex Officio
State Superintendent of Schools
West Virginia Department of Education

*Public Education
In West Virginia*

Source Book 2010

*March 2011
No. 30*

*Jorea M. Marple, Ed.D.
State Superintendent of Schools
West Virginia Department of Education*

Foreword

The 2010 edition of the West Virginia Department of Education Source Book contains current information about education in West Virginia. A comprehensive index is provided at the beginning of the document, followed by five color-coded sections:

- *Education facts at-a-glance (white), beginning with page iii*
- *Finance (blue), beginning with page 1*
- *Student enrollment (pink), beginning with page 55*
- *Personnel (green), beginning with page 65*
- *Programs (gold), beginning with page 103*

These statistical data are the most recent available and provide important information about public education. For further information about the data, please feel free to contact the Office of Communications at 304-558-2699 or any of the following:

- *Jorea Marple, Deputy Superintendent
304-558-3762*
- *Robert Hull, Assistant State Superintendent
Division of Curriculum and Instructional Services
304-558-8098*
- *Amelia Courts, Assistant State Superintendent
Division of Educator Quality and System Support
304-558-0200*
- *Joe Panetta, Assistant State Superintendent
Division of Student Support Services
304-558-2691*
- *Kathy D'Antoni, Assistant State Superintendent
Division of Technical, Adult and Institutional Education
304-558-2346*

Sincerely,

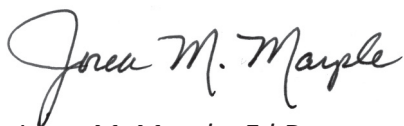

Jorea M. Marple, Ed.D.

State Superintendent of Schools



QUICK FACTS ON EDUCATION IN WEST VIRGINIA

Public School Enrollment

(Second month, 2009-10)

Prekindergarten	13,876
Kindergarten.....	21,446
Elementary (Grades 1-8).....	164,774
Secondary (Grades 9-12).....	81,732
TOTAL.....	281,828

Technical and Adult

Education Enrollments 2008-09

Secondary.....	97,016
----------------	--------

Adult Technical:

Full Time.....	3,583
Part Time.....	133,031
Adult Basic Education	32,996
TOTAL	266,626

Public High School Graduates

(2008-09)	17,677
-----------------	--------

General Education Development (GED)

Certificates Earned

(2008-09)	4,493
-----------------	-------

Number of Public Schools

(September 2010)

Elementary	574
Secondary.....	160
TOTAL.....	734

Revenues by Source (2008-09)

Local	\$969,389,001	32.7%
State	\$1,646,777,672.....	55.5%
Federal	\$351,250,717.....	11.8%
TOTAL \$2,967,417,390	100.0%	

Total Expenditures (2008-09)

Current operations.....	\$2,790,489,892
Capital outlay	\$145,537,640
Debt service	\$34,595,484
TOTAL.....	\$2,970,623,016

Per Pupil Expenditure (2008-09)

Based on student enrollment.....	\$9,675.41
----------------------------------	------------

Public Staff Ratios (2009-10)

Pupil teacher ratio	13.9
Pupil administrator ratio	151.0

Public School Personnel Employed (2009-10)

(Excluding RESAs)

No. of professional personnel (FTE)	24,648.64
No. of classroom teachers (FTE) (Included above)	19,865.66
No. of professional student support personnel (FTE) (Included above)	971.97
No. of school service personnel (FTE)	13,852.66

Standardized Test Scores (2008-09)

West Virginia American College Testing Program (ACT) composite score	20.7
--	------

West Virginia Teacher Salaries (2009-10)

A.B. degree	\$30,187 - \$50,996
A.B +15.....	\$31,040 - \$51,849
M.A.	\$32,999 - \$53,808
M.A. +15	\$33,856 - \$54,665
M.A. +30.....	\$34,713 - \$55,522
M.A. +45	\$35,474 - \$56,283
Doctorate.....	\$36,600 - \$57,409

Average Contracted Salaries (2009-10)

Professional Personnel.....	\$46,910
Classroom Teachers	\$44,506
Service Personnel.....	\$25,762

Note: (Source, The West Virginia Department of Education)

*TABLE
OF
CONTENTS*

FINANCE

PROPERTY TAXES

<i>Taxable Assessed Valuations</i>	2
<i>Levy Rates - Class I Property</i>	3
<i>Projected Gross Tax Collections</i>	4
<i>Excess Levies in Effect</i>	5
<i>Bond Elections Attempted (alphabetical)</i>	6-10
<i>Bond Elections Attempted (chronological)</i>	11-15
<i>Bonding Potential</i>	16

PUBLIC SCHOOL SUPPORT PROGRAM

<i>Financial Information</i>	17-24
<i>Student Enrollment Data</i>	25
<i>Professional Educators Data</i>	26
<i>Service Personnel Data</i>	27
<i>Personnel Ratios Data</i>	28
<i>Professional/Instructional Personnel Data</i>	29
<i>Student Support Personnel Data</i>	30

PRELIMINARY BUDGETS, COUNTY BOARDS OF EDUCATION

<i>Summary of Proposed Budgets</i>	31
--	----

REVENUES AND EXPENDITURES A2008-09

<i>Total Revenues by Source 2008-09 (graph)</i>	32
<i>Total Revenues by Source 2008-09</i>	33
<i>Total Expenditures, 2008-09</i>	34
<i>Per Pupil Expenditures (arranged)</i>	35
<i>Current Expenditures, 2008-09 (graph)</i>	36
<i>Current Expenditures, 2008-09</i>	37-39
<i>Per Pupil Expenditures, by County</i>	40
<i>Expenditures for Salaries and Employee Benefits</i>	41-43
<i>Salaries: Professional Personnel and Substitutes</i>	44
<i>Salaries: Service Personnel and Substitutes</i>	45
<i>Expenditures for Instructional Supplies</i>	46
<i>Total Expenditures</i>	47

SPECIAL FUNDING FOR THE EDUCATION OF EXCEPTIONAL CHILDREN

<i>Summary</i>	48
<i>Data Notes</i>	49
<i>State Funding</i>	50-51
<i>Federal Funding</i>	52-53
<i>State and Federal Special Education Allocations</i>	54

STUDENT ENROLLMENTS

ENROLLMENT, SECOND MONTH, 2009-10

Public School Headcount Enrollment by Grade..... 56-57

Comparison of Enrollment Factors 58-64

PERSONNEL

PROFESSIONAL EDUCATORS

<i>Classification of Professional Personnel by Assignment and Funding Source</i>	66
<i>Distribution of Professional Educators (Eligible for State Aid Funding)</i>	67
<i>Distribution of Student Support Personnel (Eligible for State Aid Funding)</i>	68
<i>Average Contracted Salaries - Professional Personnel</i>	69
<i>Average Contracted Salaries - Classroom Teachers</i>	70
<i>Teachers' State Basic Salary Schedule</i>	71
<i>Teachers' State Equity Supplement Schedule</i>	72
<i>Teachers' State Minimum Salary Schedule with Equity</i>	73
<i>Principals and Assistant Principals State Increment Schedule</i>	74
<i>History of Salary Increases - Teachers</i>	75

DEMOGRAPHICS OF EDUCATORS

<i>A Profile of West Virginia Public School Educators</i>	76
<i>A Profile of West Virginia Public School Administrators</i>	77
<i>Distribution by Age of Educators</i>	78
<i>Distribution by Age of Administrators</i>	79
<i>Experience in Years by Percentage of Educators</i>	80
<i>Experience in Years by Percentage of Administrators</i>	81
<i>Salary Classification of Educators</i>	82
<i>Salary Classification of Administrators</i>	83
<i>Experience and Salary Classification of Employed Educators</i>	84
<i>Experience and Salary Classification of Employed Administrators</i>	84
<i>Average Salaries for Public School Educators</i>	85
<i>Average Salaries for Classroom Teachers</i>	86
<i>Average Salaries for Beginning Classroom Teachers</i>	87
<i>West Virginia Educators Holding Permanent Licenses</i>	88
<i>Professional Posted Positions by Specialization</i>	89
<i>Professional Positions Not Filled and Reasons</i>	90
<i>Professional Posted Positions by Specialization</i>	91
<i>Reasons for Not Returning Educators</i>	92
<i>Trend Data Related to Personnel on Less than a Professional License</i>	93
<i>Non-Returning Educators Terminated Due to a Reduction in Force</i>	94

SERVICE PERSONNEL

<i>Classification of Service Personnel by Assignment and Funding Source</i>	95
<i>Distribution of Service Personnel (Eligible for State Aid Funding)</i>	96
<i>Average Contracted Salaries - Service Personnel</i>	97
<i>Service Personnel State Basic Monthly Pay Scale</i>	98
<i>Service Personnel State Equity Monthly Supplement Pay Scale</i>	99
<i>Service Personnel State Minimum Monthly Pay Scale with Equity</i>	100
<i>History of Salary Increases - Service Personnel</i>	101
<i>Service Personnel Job Titles by Pay Grade</i>	102

PROGRAMS

<i>CHILD NUTRITION PROGRAMS</i>	
<i>Average Number of Meals Served Daily</i>	104
<i>TITLE I FUNDS</i>	
<i>Summary</i>	105
<i>Description of Approved Expenditures</i>	106-108
<i>TITLE II PART A</i>	
<i>Summary</i>	109-110
<i>TITLE II PART B</i>	
<i>Summary</i>	111
<i>TITLE III</i>	
<i>Summary</i>	112
<i>TITLE IV PART A</i>	
<i>Summary</i>	113
<i>County Allocations</i>	114-115
<i>TITLE VI PART B</i>	
<i>Summary</i>	116
<i>EXCEPTIONAL CHILDREN</i>	
<i>Second Month Report, Student Count</i>	117
<i>Second Month Report, Exceptional Student Count</i>	118
<i>Medicaid</i>	119
<i>Preschool Children with Disabilities</i>	120
<i>Services to Students with Deafblindness</i>	120
<i>SCHOOL TRANSPORTATION</i>	
<i>Program Summary</i>	121
<i>SCHOOL FACILITIES</i>	
<i>Board Approved Comprehensive Facilities Plans</i>	122
<i>TECHNICAL AND ADULT EDUCATION SERVICES</i>	
<i>Summary of Enrollment, Programs and Facilities</i>	123
<i>Adult Basic Education, Funding and Enrollments</i>	124
<i>Placement of Graduates 1983-2009</i>	125
<i>State Appropriations, 1980-2010</i>	126
<i>Distribution of Technical and Adult Education Facilities (map)</i>	127
<i>High Schools That Work and Making Middle Grades Work Sites (map)</i>	128
<i>Cedar Lakes Conference Center</i>	129

FINANCE

**COUNTY BOARDS OF EDUCATION
TAXABLE ASSESSED VALUATIONS
FOR THE 2009-10 FISCAL YEAR**

County	Class I Assessed Valuations	Class II Assessed Valuations	Class III Assessed Valuations	Class IV Assessed Valuations	Total Assessed Valuations
Barbour	-	141,803,202	198,435,549	46,615,808	386,854,559
Berkeley	-	3,380,515,434	1,509,926,451	493,293,342	5,383,735,227
Boone	-	186,685,819	1,293,063,871	62,906,929	1,542,656,619
Braxton	-	156,516,596	280,505,727	38,852,463	475,874,786
Brooke	-	260,672,282	95,108,865	425,470,630	781,251,777
Cabell	-	1,278,394,620	747,607,412	1,049,495,999	3,075,498,031
Calhoun	-	70,185,971	145,904,990	9,312,806	225,403,767
Clay	-	62,823,861	228,314,351	12,764,841	303,903,053
Doddridge	-	113,617,214	291,341,671	8,762,418	413,721,303
Fayette	-	401,653,900	568,968,134	211,406,917	1,182,028,951
Gilmer	-	74,335,867	225,215,992	23,743,258	323,295,117
Grant	-	231,941,186	515,393,477	45,822,429	793,157,092
Greenbrier	-	685,683,153	656,741,937	207,456,770	1,549,881,860
Hampshire	-	831,034,992	510,047,890	56,361,717	1,397,444,599
Hancock	-	354,673,830	343,616,585	253,532,707	951,823,122
Hardy	-	433,673,420	317,096,304	104,313,978	855,083,702
Harrison	-	1,037,596,590	1,133,973,731	768,988,952	2,940,559,273
Jackson	-	402,985,608	611,096,113	126,939,456	1,141,021,177
Jefferson	-	2,520,735,550	963,739,417	438,125,221	3,922,600,188
Kanawha	-	3,098,168,674	2,394,145,042	2,812,007,015	8,304,320,731
Lewis	-	224,261,952	610,200,456	58,373,396	892,835,804
Lincoln	-	126,384,982	342,931,264	17,313,711	486,629,957
Logan	-	225,588,340	1,039,301,564	109,515,633	1,374,405,537
Marion	-	863,517,230	710,294,806	494,180,413	2,067,992,449
Marshall	-	355,670,763	1,036,080,878	210,659,399	1,602,411,040
Mason	-	342,549,508	626,790,706	89,173,565	1,058,513,779
McDowell	-	45,997,994	809,192,759	89,809,562	945,000,315
Mercer	-	620,469,502	575,533,719	312,067,586	1,508,070,807
Mineral	-	513,009,477	337,664,173	86,972,451	937,646,101
Mingo	-	138,024,175	817,008,533	92,817,772	1,047,850,480
Monongalia	-	1,498,834,029	1,551,377,165	773,415,520	3,823,626,714
Monroe	-	185,287,361	141,216,788	13,494,611	339,998,760
Morgan	-	731,896,171	303,109,694	41,891,984	1,076,897,849
Nicholas	-	297,366,250	457,500,921	110,677,560	865,544,731
Ohio	-	746,909,689	275,004,211	605,945,199	1,627,859,099
Pendleton	-	242,550,302	122,070,450	15,667,683	380,288,435
Pleasants	-	104,686,310	442,975,291	34,875,743	582,537,344
Pocahontas	-	213,941,176	456,153,501	29,490,237	699,584,914
Preston	-	513,180,116	507,272,431	105,706,160	1,126,158,707
Putnam	-	1,262,149,765	1,222,671,569	165,680,161	2,650,501,495
Raleigh	-	929,338,804	1,280,453,532	452,281,897	2,662,074,233
Randolph	-	380,067,776	434,155,054	145,813,684	960,036,514
Ritchie	-	170,299,495	257,694,139	44,893,747	472,887,381
Roane	-	174,872,765	183,848,080	40,240,438	398,961,283
Summers	-	153,961,381	161,023,955	41,490,602	356,475,938
Taylor	-	255,719,900	217,590,989	62,106,790	535,417,679
Tucker	-	148,246,462	292,037,802	60,021,771	500,306,035
Tyler	-	120,176,420	214,013,789	31,393,750	365,583,959
Upshur	-	348,320,765	424,800,102	104,954,517	878,075,384
Wayne	-	365,648,554	575,913,523	126,930,274	1,068,492,351
Webster	-	29,783,490	214,086,537	19,641,195	263,511,222
Wetzel	-	185,018,314	286,293,716	145,199,690	616,511,720
Wirt	-	68,116,548	47,626,144	10,193,692	125,936,384
Wood	-	1,540,403,870	774,281,854	781,382,112	3,096,067,836
Wyoming	-	72,077,886	825,155,684	50,009,280	947,242,850
Total	-	29,918,025,291	31,603,569,288	12,770,455,441	74,292,050,020

Source: Levy Order and Rate Sheet submitted by each county board for the 2009-10 fiscal year.

OSF2
05/20/09

Taxable Assessed Valuations 10

ATTACHMENT 1

**COUNTY BOARDS OF EDUCATION
LEVY RATES - CLASS I PROPERTY
FOR THE 2009-10 FISCAL YEAR**

County	Current Expense Purposes	Permanent Improvement Purposes	Excess Levy Purposes	Percent of Maximum (22.95)	Bond Purposes	Total Levy Rates
Barbour	19.40	-	-	-	-	19.40
Berkeley	19.40	-	22.50	98.0%	2.61	44.51
Boone	19.40	-	22.95	100.0%	-	42.35
Braxton	19.40	-	-	-	8.36	27.76
Brooke	19.40	-	22.95	100.0%	5.48	47.83
Cabell	17.90	1.50	22.95	100.0%	6.30	48.65
Calhoun	19.40	-	0.53	2.3%	4.58	24.51
Clay	19.40	-	6.50	28.3%	-	25.90
Doddridge	19.40	-	22.95	100.0%	5.95	48.30
Fayette	19.40	-	22.95	100.0%	-	42.35
Gilmer	19.40	-	8.65	37.7%	-	28.05
Grant	19.40	-	-	-	-	19.40
Greenbrier	19.40	-	11.475	50.0%	10.89	41.77
Hampshire	19.40	-	-	-	-	19.40
Hancock	19.40	-	22.95	100.0%	-	42.35
Hardy	19.40	-	-	-	-	19.40
Harrison	19.40	-	20.33	88.6%	-	39.73
Jackson	19.40	-	22.95	100.0%	-	42.35
Jefferson	19.40	-	22.95	100.0%	1.72	44.07
Kanawha	19.40	-	17.77	77.4%	1.10	38.27
Lewis	19.40	-	12.62	55.0%	-	32.02
Lincoln	19.40	-	22.95	100.0%	-	42.35
Logan	19.40	-	22.95	100.0%	-	42.35
Marion	19.40	-	22.95	100.0%	-	42.35
Marshall	19.40	-	22.49	98.0%	5.18	47.07
Mason	19.40	-	20.48	89.2%	4.01	43.89
McDowell	19.40	-	22.95	100.0%	-	42.35
Mercer	19.40	-	22.95	100.0%	-	42.35
Mineral	19.40	-	22.95	100.0%	-	42.35
Mingo	17.90	1.50	22.95	100.0%	-	42.35
Monongalia	19.40	-	17.21	75.0%	3.04	39.65
Monroe	17.90	1.50	17.21	75.0%	2.04	38.65
Morgan	19.40	-	19.16	83.5%	-	38.56
Nicholas	19.40	-	13.31	58.0%	-	32.71
Ohio	19.40	-	21.92	95.5%	2.43	43.75
Pendleton	19.40	-	-	-	-	19.40
Pleasants	19.40	-	19.06	83.1%	-	38.46
Pocahontas	19.40	-	-	-	-	19.40
Preston	19.40	-	4.63	20.2%	-	24.03
Putnam	19.40	-	22.95	100.0%	-	42.35
Raleigh	19.40	-	22.95	100.0%	-	42.35
Randolph	19.40	-	-	-	-	19.40
Ritchie	19.40	-	14.92	65.0%	-	34.32
Roane	19.40	-	-	-	2.37	21.77
Summers	19.40	-	-	-	-	19.40
Taylor	19.40	-	11.475	50.0%	6.02	36.90
Tucker	19.40	-	-	-	-	19.40
Tyler	19.40	-	22.95	100.0%	-	42.35
Upshur	19.40	-	9.83	42.8%	-	29.23
Wayne	19.40	-	22.95	100.0%	-	42.35
Webster	19.40	-	-	-	-	19.40
Wetzel	19.40	-	22.95	100.0%	-	42.35
Wirt	19.40	-	20.66	90.0%	-	40.06
Wood	19.40	-	18.36	80.0%	3.73	41.49
Wyoming	17.90	1.50	22.95	100.0%	2.15	44.50
State	55	4	43	43	18	55

OSF2

05/20/09

Taxable Assessed Valuations 10

**COUNTY BOARDS OF EDUCATION
SUMMARY OF PROJECTED GROSS TAX COLLECTIONS
FOR THE 2009-10 FISCAL YEAR**

County	Current Expense Purposes	Permanent Improvement Purposes	Excess Levy Purposes	Bond Purposes	Total
Barbour	2,451,795	-	-	-	2,451,795
Berkeley	28,661,385	-	33,241,297	3,855,990	65,758,672
Boone	11,246,675	-	13,304,700	-	24,551,375
Braxton	3,085,503	-	-	1,329,630	4,415,133
Brooke	5,051,105	-	5,975,405	1,426,808	12,453,318
Cabell	17,443,913	1,461,780	22,365,240	6,134,605	47,405,538
Calhoun	1,476,812	-	40,346	348,649	1,865,807
Clay	2,114,531	-	708,477	-	2,823,008
Doddridge	2,769,642	-	3,276,459	849,452	6,895,553
Fayette	7,614,128	-	9,007,433	-	16,621,561
Gilmer	2,220,347	-	990,000	-	3,210,347
Grant	5,254,967	-	-	-	5,254,967
Greenbrier	9,366,633	-	5,540,315	5,257,868	20,164,816
Hampshire	7,619,755	-	-	-	7,619,755
Hancock	6,010,013	-	7,109,783	-	13,119,796
Hardy	4,952,796	-	-	-	4,952,796
Harrison	18,792,865	-	19,693,760	-	38,486,625
Jackson	7,290,740	-	8,624,870	-	15,915,610
Jefferson	20,658,924	-	24,439,294	1,831,616	46,929,834
Kanawha	52,420,634	-	48,016,220	2,958,794	103,395,648
Lewis	6,058,270	-	3,940,998	-	9,999,268
Lincoln	3,285,875	-	3,887,156	-	7,173,031
Logan	9,790,104	-	11,581,592	-	21,371,696
Marion	12,697,175	-	15,020,626	-	27,717,801
Marshall	11,054,708	-	12,815,483	2,951,721	26,821,912
Mason	6,884,975	-	7,268,262	1,423,131	15,576,368
McDowell	7,154,730	-	8,463,973	-	15,618,703
Mercer	9,295,208	-	10,996,135	-	20,291,343
Mineral	5,285,657	-	6,252,877	-	11,538,534
Mingo	7,008,483	587,303	8,985,736	-	16,581,522
Monongalia	23,855,867	-	21,162,859	3,738,239	48,756,965
Monroe	1,771,062	148,413	1,702,792	201,842	3,824,109
Morgan	5,516,970	-	5,448,719	-	10,965,689
Nicholas	5,562,846	-	3,816,571	-	9,379,417
Ohio	9,734,178	-	10,998,617	1,219,281	21,952,076
Pendleton	2,009,943	-	-	-	2,009,943
Pleasants	4,114,307	-	4,042,201	-	8,156,508
Pocahontas	4,598,687	-	-	-	4,598,687
Preston	6,747,853	-	1,610,442	-	8,358,295
Putnam	15,670,750	-	18,538,336	-	34,209,086
Raleigh	17,051,862	-	20,172,176	-	37,224,038
Randolph	5,975,220	-	-	-	5,975,220
Ritchie	3,008,844	-	2,314,019	-	5,322,863
Roane	2,417,433	-	-	295,326	2,712,759
Summers	2,168,883	-	-	-	2,168,883
Taylor	3,162,648	-	1,870,690	981,399	6,014,737
Tucker	3,307,178	-	-	-	3,307,178
Tyler	2,370,648	-	2,804,452	-	5,175,100
Upshur	5,462,381	-	2,767,794	-	8,230,175
Wayne	6,872,784	-	8,130,433	-	15,003,217
Webster	1,929,288	-	-	-	1,929,288
Wetzel	4,066,260	-	4,810,343	-	8,876,603
Wirt	712,974	-	759,281	-	1,472,255
Wood	18,048,719	-	17,081,159	3,470,192	38,600,070
Wyoming	6,524,220	546,722	8,364,851	783,635	16,219,428
Total	457,680,153	2,744,218	427,942,172	39,058,178	927,424,721

OSF2
05/20/09

**COUNTY BOARDS OF EDUCATION
EXCESS LEVIES IN EFFECT
2009-10 YEAR**

County	Date of Election	Percent of Votes for Levy	Class I Levy Rate Per \$100	Percent of Maximum (22.95)	Max Rate Allowed By Levy Call	Number of Years	Expiration Date
Barbour	-	-	-	-	-	-	-
Berkeley	05-09-06	71.3%	22.50	98.0%	22.50	4	6-30-11
Boone	11-02-04	78.1%	22.95	100.0%	22.95	5	6-30-10
Braxton	-	-	-	-	-	-	-
Brooke	11-04-08	66.6%	22.95	100.0%	22.95	5	6-30-14
Cabell	05-11-04	67.5%	22.95	100.0%	22.95	5	6-30-10
Calhoun	11-07-06	65.4%	0.53	2.3%	0.53	5	6-30-12
Clay	01-19-02	68.2%	6.50	28.3%	6.50	5	6-30-12
Doddridge	11-04-08	54.5%	22.95	100.0%	22.95	5	6-30-14
Fayette	05-13-08	71.3%	22.95	100.0%	22.95	5	6-30-14
Gilmer	09-15-07	72.8%	8.65	37.7%	9.18	5	6-30-13
Grant	-	-	-	-	-	-	-
Greenbrier	05-23-08	69.0%	11.48	50.0%	11.48	5	6-30-14
Hampshire	-	-	-	-	-	-	-
Hancock	11-04-08	66.3%	22.95	100.0%	22.95	5	6-30-14
Hardy	-	-	-	-	-	-	-
Harrison	12-17-05	63.4%	20.33	88.6%	20.66	5	6-30-11
Jackson	05-13-08	64.4%	22.95	100.0%	22.95	5	6-30-14
Jefferson	11-07-06	69.0%	22.95	100.0%	22.95	4	6-30-11
Kanawha	05-13-08	60.4%	17.77	77.4%	22.95	5	6-30-14
Lewis	02-19-05	71.1%	12.62	55.0%	13.54	5	6-30-10
Lincoln	11-04-08	61.7%	22.95	100.0%	22.95	5	6-30-14
Logan	11-04-08	78.4%	22.95	100.0%	22.95	5	6-30-14
Marion	02-07-09	65.7%	22.95	100.0%	22.95	5	6-30-14
Marshall	12-14-07	65.4%	22.49	98.0%	22.95	5	6-30-13
Mason	11-04-08	57.1%	20.48	89.2%	20.48	5	6-30-14
McDowell	02-07-09	93.5%	22.95	100.0%	22.95	5	6-30-14
Mercer	11-02-04	72.0%	22.95	100.0%	22.95	5	6-30-10
Mineral	05-21-05	77.7%	22.95	100.0%	22.95	5	6-30-11
Mingo	01-17-09	78.2%	22.95	100.0%	22.95	5	6-30-14
Monongalia	11-07-06	67.7%	17.21	75.0%	17.21	5	6-30-12
Monroe	11-02-04	61.0%	17.21	75.0%	17.21	5	6-30-10
Morgan	11-04-08	57.2%	19.16	83.5%	22.95	5	6-30-14
Nicholas	11-02-04	50.9%	13.31	58.0%	13.31	5	6-30-11
Ohio	11-02-04	74.9%	21.92	95.5%	22.95	5	6-30-10
Pendleton	-	-	-	-	-	-	-
Pleasants	11-04-08	70.1%	19.06	83.1%	19.06	5	6-30-14
Pocahontas	-	-	-	-	-	-	-
Preston	11-07-06	59.7%	4.63	20.2%	5.50	3	6-30-10
Putnam	11-22-05	68.3%	22.95	100.0%	22.95	5	6-30-11
Raleigh	02-28-09	86.9%	22.95	100.0%	22.95	5	6-30-14
Randolph	-	-	-	-	-	-	-
Ritchie	11-07-06	66.3%	14.92	65.0%	14.92	3	6-30-10
Roane	-	-	-	-	-	-	-
Summers	-	-	-	-	-	-	-
Taylor	01-21-06	62.1%	11.48	50.0%	11.48	5	6-30-11
Tucker	-	-	-	-	-	-	-
Tyler	12-14-07	83.4%	22.95	100.0%	22.95	5	6-30-13
Upshur	02-07-09	51.2%	9.83	42.8%	9.83	5	6-30-14
Wayne	12-20-08	80.9%	22.95	100.0%	22.95	5	6-30-14
Webster	-	-	-	-	-	-	-
Wetzel	12-14-07	82.1%	22.95	100.0%	22.95	5	6-30-13
Wirt	05-09-06	70.9%	20.66	90.0%	20.66	5	6-30-12
Wood	11-04-08	68.7%	18.36	80.0%	18.36	5	6-30-14
Wyoming	11-10-08	78.0%	22.95	100.0%	22.95	5	6-30-14
State (With Levies)	43	69.1%	18.91	82.4%	19.21	4.9	-

OSF
03/05/10
EXCLVY 10

**COUNTY BOARDS OF EDUCATION
BOND ELECTIONS ATTEMPTED SINCE 1971
PRESENTED IN ALPHABETICAL ORDER**

County	Year of Bond Election	Previous Issue Passed	Amount of Bond Issue Proposed	Amount of Bond Issue Approved	Amount of Bond Issue Defeated	Percent of Voters For Bond
Barbour (1)	1978	1969	4,529,000	--	4,529,000	50.6%
Barbour (2)	1978	1969	4,529,000	--	4,529,000	55.0%
Barbour (3)	1979	1969	4,529,000	4,529,000	--	61.3%
Barbour (4)	1998	1979	8,000,000	--	8,000,000	45.8%
Barbour (5)	2000	1979	7,500,000	7,500,000	--	55.4%
Berkeley (1)	1974	--	3,560,000	3,560,000	--	69.2%
Berkeley (2)	1983	1974	12,700,000	--	12,700,000	47.7%
Berkeley (3)	1984	1974	12,000,000	--	12,000,000	49.6%
Berkeley (4)	1987	1974	10,960,000	10,960,000	--	66.0%
Berkeley (5)	1993	1987	42,200,000	--	42,200,000	35.7%
Berkeley (6)	1995	1987	15,950,000	15,950,000	--	56.4%
Berkeley (7)	2001	1995	27,800,000	27,800,000	--	63.3%
Berkeley (8)	2009	2001	51,500,000	51,500,000	--	63.6%
Boone	1977	--	6,745,000	6,745,000	--	81.1%
Braxton (1)	1977	1965	2,200,000	--	2,200,000	26.0%
Braxton (2)	1978	1965	2,840,000	--	2,840,000	32.4%
Braxton (3)	1997	1965	11,660,000	--	11,660,000	20.7%
Braxton (4)	2003	1965	7,200,000	--	7,200,000	42.7%
Braxton (5)	2008	1965	16,100,000	16,100,000	--	52.0%
Brooke (1)	1977	1965	5,565,000	--	5,565,000	32.7%
Brooke (2)	1981	1965	9,865,000	9,865,000	--	63.1%
Brooke (3)	2000	1981	15,000,000	15,000,000	--	57.7%
Cabell (1)	1980	1938	32,890,000	--	32,890,000	35.6%
Cabell (2)	1990	1938	45,000,000	45,000,000	--	57.2%
Cabell (3)	2006	1990	60,455,000	60,455,000	--	55.4%
Calhoun (1)	1975	1949	2,100,000	--	2,100,000	32.0%
Calhoun (2)	1975	1949	2,100,000	--	2,100,000	32.5%
Calhoun (3)	1990	1949	5,375,000	--	5,375,000	40.1%
Calhoun (4)	1990	1949	5,375,000	--	5,375,000	37.1%
Calhoun (5)	1996	1949	3,370,000	3,370,000	--	50.7%
Clay	--	1969	--	--	--	--
Doddridge (1)	1977	1940	1,871,358	--	1,871,358	17.2%
Doddridge (2)	2003	1940	8,900,000	8,900,000	--	61.5%
Fayette (1)	1973	1951	7,600,000	7,600,000	--	76.1%
Fayette (2)	2001	1973	39,000,000	--	39,000,000	13.8%
Fayette (3)	2009	1973	49,000,000	--	49,000,000	22.6%
Gilmer (1)	1974	1955	1,825,000	--	1,825,000	33.0%
Gilmer (2)	1974	1955	2,125,000	--	2,125,000	48.0%
Gilmer (3)	1975	1955	2,125,000	--	2,125,000	50.0%
Gilmer (4)	1976	1955	2,459,000	--	2,459,000	53.6%
Gilmer (5)	1976	1955	2,459,000	--	2,459,000	51.6%
Grant (1)	1998	1996	3,500,000	--	3,500,000	49.4%
Grant (2)	2008	1996	2,495,500	--	2,495,500	42.0%
Greenbrier (1)	1981	1966	10,539,000	--	10,539,000	31.0%
Greenbrier (2)	1991	1966	20,200,000	--	20,200,000	26.0%
Greenbrier (3)	1996	1966	8,000,000	8,000,000	--	60.6%
Greenbrier (4)	2001	1996	8,000,000	8,000,000	--	69.0%
Greenbrier (5)	2005	2001	12,500,000	--	12,500,000	25.8%
Greenbrier (6)	2008	2001	37,745,000	37,745,000	--	50.8%

**COUNTY BOARDS OF EDUCATION
BOND ELECTIONS ATTEMPTED SINCE 1971
PRESENTED IN ALPHABETICAL ORDER**

County	Year of Bond Election	Previous Issue Passed	Amount of Bond Issue Proposed	Amount of Bond Issue Approved	Amount of Bond Issue Defeated	Percent of Voters For Bond
Hampshire (1)	1988	1962	8,680,000	--	8,680,000	49.0%
Hampshire (2)	1989	1962	8,680,000	--	8,680,000	23.0%
Hampshire (3)	1997	1962	11,060,000	--	11,060,000	43.8%
Hampshire (4)	1998	1962	3,740,000	3,740,000	--	55.1%
Hancock (1)	1978	1961	13,885,000	--	13,885,000	47.6%
Hancock (2)	1980	1961	13,885,000	13,885,000	--	64.6%
Hancock (3)	1996	1980	12,800,000	--	12,800,000	35.0%
Hancock (4)	1997	1980	12,500,000	--	12,500,000	27.9%
Hancock (5)	2005	1980	34,000,000	--	34,000,000	28.0%
Hardy (1)	1972	--	950,000	950,000	--	65.0%
Hardy (2)	1977	1972	2,430,000	2,430,000	--	68.1%
Hardy (3)	1992	1977	8,000,000	--	8,000,000	32.0%
Hardy (4)	1994	1977	3,700,000	3,700,000	--	61.5%
Hardy (5)	2002	1994	11,970,000	--	11,970,000	46.0%
Hardy (6)	2003	1994	11,970,000	--	11,970,000	46.0%
Harrison (1)	1975	--	12,800,000	--	12,800,000	54.1%
Harrison (2)	1975	--	12,800,000	--	12,800,000	47.2%
Harrison (3)	1988	--	39,700,000	--	39,700,000	42.0%
Harrison (4)	1991	--	37,925,000	37,925,000	--	51.0%
Harrison (5)	2007	1991	42,465,000	--	42,465,000	39.2%
Jackson (1)	1974	1959	5,525,000	--	5,525,000	35.0%
Jackson (2)	2006	1959	39,380,000	--	39,380,000	25.1%
Jefferson (1)	1974	--	1,520,000	1,520,000	--	63.3%
Jefferson (2)	1989	1974	18,000,000	18,000,000	--	74.1%
Jefferson (3)	2000	1989	39,000,000	--	39,000,000	35.0%
Jefferson (4)	2004	1989	19,000,000	19,000,000	--	71.2%
Kanawha (1)	1976	1967	39,467,000	--	39,467,000	44.0%
Kanawha (2)	1989	1967	103,670,000	--	103,670,000	34.1%
Kanawha (3)	1992	1967	73,705,000	--	73,705,000	49.3%
Kanawha (4)	1995	1967	12,670,000	12,670,000	--	68.3%
Kanawha (5)	1997	1995	98,165,000	--	98,165,000	36.9%
Kanawha (6)	2000	1995	27,505,000	27,505,000	--	59.9%
Lewis (1)	1979	--	6,430,000	--	6,430,000	39.4%
Lewis (2)	2002	--	8,000,000	--	8,000,000	42.0%
Lewis (3)	2003	--	3,980,000	--	3,980,000	36.7%
Lincoln (1)	1976	1952	2,966,658	--	2,966,658	42.5%
Lincoln (2)	1976	1952	2,966,658	--	2,966,658	38.5%
Lincoln (3)	1978	1952	3,157,000	3,157,000	--	66.4%
Lincoln (4)	1991	1978	6,375,000	--	6,375,000	38.1%
Logan (1)	1983	1969	10,000,000	--	10,000,000	34.0%
Logan (2)	1991	1969	23,205,000	--	23,205,000	27.0%
Logan (3)	2003	1969	6,500,000	--	6,500,000	48.0%
Marion (1)	1975	--	12,800,000	--	12,800,000	52.5%
Marion (2)	1975	--	12,800,000	--	12,800,000	58.7%
Marion (3)	1976	--	13,475,000	--	13,475,000	46.7%
Marion (4)	1983	--	29,930,000	--	29,930,000	35.1%
Marion (5)	1988	--	32,100,000	--	32,100,000	45.0%
Marion (6)	1989	--	12,330,000	12,330,000	--	55.7%
Marion (7)	1996	1989	3,250,000	3,250,000	--	59.3%

**COUNTY BOARDS OF EDUCATION
BOND ELECTIONS ATTEMPTED SINCE 1971
PRESENTED IN ALPHABETICAL ORDER**

County	Year of Bond Election	Previous Issue Passed	Amount of Bond Issue Proposed	Amount of Bond Issue Approved	Amount of Bond Issue Defeated	Percent of Voters For Bond
Marion (8)	2000	1996	29,705,000	--	29,705,000	25.0%
Marion (9)	2001	1996	12,000,000	--	12,000,000	42.0%
Marion (10)	2002	1996	4,500,000	4,500,000	--	53.8%
Marshall (1)	1974	1965	4,350,000	4,350,000	--	75.2%
Marshall (2)	1995	1974	37,790,000	--	37,790,000	26.7%
Marshall (3)	1996	1974	19,870,000	--	19,870,000	36.8%
Marshall (4)	2006	1974	27,900,000	27,900,000	--	51.0%
Mason (1)	1980	1950	8,307,332	--	8,307,332	51.6%
Mason (2)	1980	1950	9,366,000	--	9,366,000	58.5%
Mason (3)	1980	1950	9,366,000	--	9,366,000	49.5%
Mason (4)	1989	1950	18,700,000	--	18,700,000	43.0%
Mason (5)	1990	1950	16,300,000	--	16,300,000	32.0%
Mason (6)	1991	1950	16,300,000	--	16,300,000	42.0%
Mason (7)	2000	1950	24,610,000	--	24,610,000	29.0%
Mason (8)	2004	1950	12,000,000	12,000,000	-	55.0%
McDowell (1)	1974	1964	4,000,000	4,000,000	--	73.0%
McDowell (2)	1996	1974	21,865,000	--	21,865,000	16.0%
Mercer (1)	1979	1954	16,737,000	16,737,000	--	66.2%
Mercer (2)	2001	1979	21,900,000	--	21,900,000	14.0%
Mineral (1)	1973	1938	3,354,000	3,354,000	--	79.0%
Mineral (2)	1990	1973	15,300,000	--	15,300,000	36.0%
Mineral (3)	1991	1973	7,500,000	--	7,500,000	48.0%
Mineral (4)	2001	1973	14,950,000	--	14,950,000	36.0%
Mineral (5)	2004	1973	15,800,000	--	15,800,000	42.0%
Mineral (6)	2008	1973	15,800,000	--	15,800,000	47.9%
Mineral (7)	2008	1973	15,800,000	--	15,800,000	41.6%
Mingo (1)	1978	1967	4,220,000	--	4,220,000	55.9%
Mingo (2)	1979	1967	4,220,000	4,220,000	--	61.6%
Mingo (3)	1984	1979	7,850,000	7,850,000	--	70.6%
Mingo (4)	1990	1984	13,000,000	--	13,000,000	33.0%
Mingo (5)	1990	1984	10,970,000	--	10,970,000	38.0%
Mingo (6)	1993	1984	27,000,000	--	27,000,000	29.8%
Monongalia (1)	1974	1952	7,500,000	--	7,500,000	57.1%
Monongalia (2)	1976	1952	6,995,000	6,995,000	--	66.8%
Monongalia (3)	1987	1976	29,525,000	--	29,525,000	48.0%
Monongalia (4)	1989	1976	32,500,000	32,500,000	--	62.0%
Monongalia (5)	2000	1989	80,079,000	--	80,079,000	28.0%
Monongalia (6)	2003	1989	50,000,000	50,000,000	--	73.2%
Monroe (1)	1975	1961	1,725,000	--	1,725,000	25.9%
Monroe (2)	1993	1961	3,177,915	--	3,177,915	39.3%
Monroe (3)	1998	1961	2,995,000	--	2,995,000	44.0%
Monroe (4)	1999	1961	2,100,000	2,100,000	--	53.9%
Morgan (1)	1972	1964	1,835,000	--	1,835,000	54.7%
Morgan (2)	1972	1964	1,595,000	--	1,595,000	54.8%
Morgan (3)	1974	1964	1,835,000	1,835,000	--	77.0%
Morgan (4)	1993	1974	7,500,000	--	7,500,000	32.4%
Nicholas (1)	1975	--	4,500,000	4,500,000	--	70.0%
Nicholas (2)	1988	1975	8,000,000	8,000,000	--	53.0%

**COUNTY BOARDS OF EDUCATION
BOND ELECTIONS ATTEMPTED SINCE 1971
PRESENTED IN ALPHABETICAL ORDER**

County	Year of Bond Election	Previous Issue Passed	Amount of Bond Issue Proposed	Amount of Bond Issue Approved	Amount of Bond Issue Defeated	Percent of Voters For Bond
Ohio (1)	1973	1940	14,235,000	14,235,000	--	68.4%
Ohio (2)	1986	1973	2,300,000	2,300,000	--	68.2%
Ohio (3)	1993	1986	14,800,000	14,800,000	--	77.5%
Pendleton	1979	--	1,800,000	--	1,800,000	38.8%
Pleasants (1)	1973	1959	1,800,000	1,800,000	--	60.7%
Pleasants (2)	2000	1973	15,000,000	--	15,000,000	28.0%
Pocahontas (1)	1976	1968	1,818,000	--	1,818,000	35.1%
Pocahontas (2)	1980	1968	3,280,000	--	3,280,000	37.5%
Pocahontas (3)	1980	1968	3,280,000	--	3,280,000	33.8%
Pocahontas (4)	1994	1968	400,000	--	400,000	25.0%
Preston (1)	1973	1947	4,965,000	--	4,965,000	46.6%
Preston (2)	1974	1947	5,320,000	--	5,320,000	57.3%
Preston (3)	1974	1947	5,320,000	--	5,320,000	49.2%
Preston (4)	1976	1947	6,140,000	--	6,140,000	47.1%
Preston (5)	1984	1947	10,735,000	--	10,735,000	35.1%
Preston (6)	1985	1947	11,690,000	--	11,690,000	45.3%
Preston (7)	1986	1947	15,690,000	--	15,690,000	38.5%
Preston (8)	1989	1947	8,850,000	8,850,000	--	55.0%
Preston (9)	2008	1989	49,995,000	--	49,995,000	49.7%
Putnam (1)	1974	1967	4,900,000	--	4,900,000	59.1%
Putnam (2)	1974	1967	4,900,000	--	4,900,000	48.0%
Putnam (3)	1976	1967	5,795,000	5,795,000	--	68.3%
Putnam (4)	1993	1976	39,500,000	--	39,500,000	27.1%
Putnam (5)	2001	1976	35,850,000	--	35,850,000	25.2%
Putnam (6)	2002	1976	20,500,000	--	20,500,000	46.5%
Putnam (7)	2009	1976	56,750,000	56,750,000	--	56.0%
Raleigh (1)	1973	1963	7,760,000	7,760,000	--	80.6%
Raleigh (2)	1980	1973	14,825,000	14,825,000	--	63.4%
Raleigh (3)	1991	1980	30,965,000	--	30,965,000	25.1%
Raleigh (4)	1998	1980	14,500,000	14,500,000	--	54.5%
Raleigh (5)	2004	1998	13,000,000	13,000,000	--	76.1%
Randolph (1)	1974	1951	3,580,000	3,580,000	--	64.4%
Randolph (2)	1996	1974	19,365,000	--	19,365,000	35.0%
Randolph (3)	1996	1974	19,365,500	--	19,365,500	36.9%
Ritchie (1)	1973	--	1,972,000	--	1,972,000	47.0%
Ritchie (2)	1979	--	3,326,528	--	3,326,528	35.3%
Roane (1)	1976	1946	3,430,000	--	3,430,000	54.1%
Roane (2)	1977	1946	7,386,500	3,710,000	3,676,500	63.7%
Roane (3)	1994	1977	3,700,000	3,700,000	--	64.3%
Summers	1992	--	3,300,000	--	3,300,000	46.7%
Taylor (1)	1974	1968	939,000	--	939,000	25.4%
Taylor (2)	1976	1968	1,515,533	--	1,515,533	43.3%
Taylor (3)	1978	1968	3,000,000	--	3,000,000	45.7%
Taylor (4)	1987	1968	6,700,000	6,700,000	--	61.6%
Taylor (5)	1999	1987	9,700,000	--	9,700,000	37.0%
Taylor (6)	2001	1987	5,120,995	5,120,995	--	77.7%
Taylor (7)	2002	2001	10,990,000	10,990,000	--	57.5%
Tucker (1)	1975	1938	1,285,000	1,285,000	--	60.3%
Tucker (2)	1994	1975	6,385,000	--	6,385,000	33.0%

**COUNTY BOARDS OF EDUCATION
BOND ELECTIONS ATTEMPTED SINCE 1971
PRESENTED IN ALPHABETICAL ORDER**

County	Year of Bond Election	Previous Issue Passed	Amount of Bond Issue Proposed	Amount of Bond Issue Approved	Amount of Bond Issue Defeated	Percent of Voters For Bond
Tyler (1)	1973	--	1,855,000	1,855,000	--	83.3%
Tyler (2)	1990	1973	6,200,000	6,200,000	--	63.9%
Upshur	1973	1956	3,552,000	3,552,000	--	70.6%
Wayne (1)	1977	--	7,155,000	--	7,155,000	46.5%
Wayne (2)	1985	--	14,300,000	14,300,000	--	53.0%
Wayne (3)	1999	--	32,000,000	--	32,000,000	20.0%
Webster (1)	1972	1953	1,535,000	1,535,000	--	75.9%
Wetzel (1)	1972	--	3,740,000	--	3,740,000	48.9%
Wetzel (2)	1974	--	4,955,000	4,955,000	--	72.5%
Wetzel (3)	1986	1974	8,900,000	8,900,000	--	61.5%
Wirt (1)	1975	1961	935,000	--	935,000	27.6%
Wirt (2)	1991	1961	1,500,000	1,500,000	--	56.0%
Wood (1)	1971	1964	8,995,000	8,995,000	--	61.4%
Wood (2)	1982	1971	18,100,000	--	18,100,000	46.8%
Wood (3)	1984	1971	3,950,000	3,950,000	--	57.8%
Wood (4)	1990	1984	9,995,000	9,995,000	--	56.8%
Wood (5)	1990	1990	12,550,000	--	12,550,000	31.2%
Wood (6)	1991	1990	7,637,000	--	7,637,000	36.3%
Wood (7)	2004	1990	35,000,000	35,000,000	--	67.2%
Wyoming (1)	1975	1959	5,875,000	--	5,875,000	50.5%
Wyoming (2)	1976	1959	7,720,000	--	7,720,000	57.9%
Wyoming (3)	1977	1959	7,720,000	--	7,720,000	55.0%
Wyoming (4)	1992	1959	10,000,000	--	10,000,000	42.0%
Wyoming (5)	1995	1959	14,000,000	--	14,000,000	35.0%
Wyoming (6)	2000	1959	7,000,000	7,000,000	--	61.0%

NOTE: Percent of votes required for approval of bond levy changed from 60% to 50% by constitutional amendment adopted at the General Election on Nov. 2, 1982.

OSF2
03/05/10
Bonds 09

**COUNTY BOARDS OF EDUCATION
BOND ELECTIONS ATTEMPTED SINCE 1971
PRESENTED IN CHRONOLOGICAL ORDER**

County	Year of Bond Election	Previous Issue Passed	Amount of Bond Issue Proposed	Amount of Bond Issue Approved	Amount of Bond Issue Defeated	Percent of Voters For Bond
Wood (1)	1971	1964	8,995,000	8,995,000	--	61.4%
Hardy (1)	1972	--	950,000	950,000	--	65.0%
Morgan (1)	1972	1964	1,835,000	--	1,835,000	54.7%
Morgan (2)	1972	1964	1,595,000	--	1,595,000	54.8%
Webster (1)	1972	1953	1,535,000	1,535,000	--	75.9%
Wetzel (1)	1972	--	3,740,000	--	3,740,000	48.9%
Fayette (1)	1973	1951	7,600,000	7,600,000	--	76.1%
Mineral (1)	1973	1938	3,354,000	3,354,000	--	79.0%
Ohio (1)	1973	1940	14,235,000	14,235,000	--	68.4%
Pleasants (1)	1973	1959	1,800,000	1,800,000	--	60.7%
Preston (1)	1973	1947	4,965,000	--	4,965,000	46.6%
Raleigh (1)	1973	1963	7,760,000	7,760,000	--	80.6%
Ritchie (1)	1973	--	1,972,000	--	1,972,000	47.0%
Tyler (1)	1973	--	1,855,000	1,855,000	--	83.3%
Upshur	1973	1956	3,552,000	3,552,000	--	70.6%
Berkeley (1)	1974	--	3,560,000	3,560,000	--	69.2%
Gilmer (1)	1974	1955	1,825,000	--	1,825,000	33.0%
Gilmer (2)	1974	1955	2,125,000	--	2,125,000	48.0%
Jackson	1974	1959	5,525,000	--	5,525,000	35.0%
Jefferson (1)	1974	--	1,520,000	1,520,000	--	63.3%
Marshall (1)	1974	1965	4,350,000	4,350,000	--	75.2%
McDowell (1)	1974	1964	4,000,000	4,000,000	--	73.0%
Monongalia (1)	1974	1952	7,500,000	--	7,500,000	57.1%
Morgan (3)	1974	1964	1,835,000	1,835,000	--	77.0%
Preston (2)	1974	1947	5,320,000	--	5,320,000	57.3%
Preston (3)	1974	1947	5,320,000	--	5,320,000	49.2%
Putnam (1)	1974	1967	4,900,000	--	4,900,000	59.1%
Putnam (2)	1974	1967	4,900,000	--	4,900,000	48.0%
Randolph (1)	1974	1951	3,580,000	3,580,000	--	64.4%
Taylor (1)	1974	1968	939,000	--	939,000	25.4%
Wetzel (2)	1974	--	4,955,000	4,955,000	--	72.5%
Calhoun (1)	1975	1949	2,100,000	--	2,100,000	32.0%
Calhoun (2)	1975	1949	2,100,000	--	2,100,000	32.5%
Gilmer (3)	1975	1955	2,125,000	--	2,125,000	50.0%
Harrison (1)	1975	--	12,800,000	--	12,800,000	54.1%
Harrison (2)	1975	--	12,800,000	--	12,800,000	47.2%
Marion (1)	1975	--	12,800,000	--	12,800,000	52.5%
Marion (2)	1975	--	12,800,000	--	12,800,000	58.7%
Monroe (1)	1975	1961	1,725,000	--	1,725,000	25.9%
Nicholas (1)	1975	--	4,500,000	4,500,000	--	70.0%
Tucker (1)	1975	1938	1,285,000	1,285,000	--	60.3%
Wirt (1)	1975	1961	935,000	--	935,000	27.6%
Wyoming (1)	1975	1959	5,875,000	--	5,875,000	50.5%
Gilmer (4)	1976	1955	2,459,000	--	2,459,000	53.6%
Gilmer (5)	1976	1955	2,459,000	--	2,459,000	51.6%
Kanawha (1)	1976	1967	39,467,000	--	39,467,000	44.0%
Lincoln (1)	1976	1952	2,966,658	--	2,966,658	42.5%
Lincoln (2)	1976	1952	2,966,658	--	2,966,658	38.5%
Marion (3)	1976	--	13,475,000	--	13,475,000	46.7%
Monongalia (2)	1976	1952	6,995,000	6,995,000	--	66.8%
Pocahontas (1)	1976	1968	1,818,000	--	1,818,000	35.1%
Preston (4)	1976	1947	6,140,000	--	6,140,000	47.1%
Putnam (3)	1976	1967	5,795,000	5,795,000	--	68.3%
Roane (1)	1976	1946	3,430,000	--	3,430,000	54.1%
Taylor (2)	1976	1968	1,515,533	--	1,515,533	43.3%
Wyoming (2)	1976	1959	7,720,000	--	7,720,000	57.9%

**COUNTY BOARDS OF EDUCATION
BOND ELECTIONS ATTEMPTED SINCE 1971
PRESENTED IN CHRONOLOGICAL ORDER**

County	Year of Bond Election	Previous Issue Passed	Amount of Bond Issue Proposed	Amount of Bond Issue Approved	Amount of Bond Issue Defeated	Percent of Voters For Bond
Boone	1977	--	6,745,000	6,745,000	--	81.1%
Braxton (1)	1977	1965	2,200,000	--	2,200,000	26.0%
Brooke (1)	1977	1965	5,565,000	--	5,565,000	32.7%
Doddridge (1)	1977	1940	1,871,358	--	1,871,358	17.2%
Hardy (2)	1977	1972	2,430,000	2,430,000	--	68.1%
Roane (2)	1977	1946	7,386,500	3,710,000	3,676,500	63.7%
Wayne (1)	1977	--	7,155,000	--	7,155,000	46.5%
Wyoming (3)	1977	1959	7,720,000	--	7,720,000	55.0%
Barbour (1)	1978	1969	4,529,000	--	4,529,000	50.6%
Barbour (2)	1978	1969	4,529,000	--	4,529,000	55.0%
Braxton (2)	1978	1965	2,840,000	--	2,840,000	32.4%
Hancock (1)	1978	1961	13,885,000	--	13,885,000	47.6%
Lincoln (3)	1978	1952	3,157,000	3,157,000	--	66.4%
Mingo (1)	1978	1967	4,220,000	--	4,220,000	55.9%
Taylor (3)	1978	1968	3,000,000	--	3,000,000	45.7%
Barbour (3)	1979	1969	4,529,000	4,529,000	--	61.3%
Lewis (1)	1979	--	6,430,000	--	6,430,000	39.4%
Mercer (1)	1979	1954	16,737,000	16,737,000	--	66.2%
Mingo (2)	1979	1967	4,220,000	4,220,000	--	61.6%
Pendleton	1979	--	1,800,000	--	1,800,000	38.8%
Ritchie (2)	1979	--	3,326,528	--	3,326,528	35.3%
Cabell (1)	1980	1938	32,890,000	--	32,890,000	35.6%
Hancock (2)	1980	1961	13,885,000	13,885,000	--	64.6%
Mason (1)	1980	1950	8,307,332	--	8,307,332	51.6%
Mason (2)	1980	1950	9,366,000	--	9,366,000	58.5%
Mason (3)	1980	1950	9,366,000	--	9,366,000	49.5%
Pocahontas (2)	1980	1968	3,280,000	--	3,280,000	37.5%
Pocahontas (3)	1980	1968	3,280,000	--	3,280,000	33.8%
Raleigh (2)	1980	1973	14,825,000	14,825,000	--	63.4%
Brooke (2)	1981	1965	9,865,000	9,865,000	--	63.1%
Greenbrier (1)	1981	1966	10,539,000	--	10,539,000	31.0%
Wood (2)	1982	1971	18,100,000	--	18,100,000	46.8%
Berkeley (2)	1983	1974	12,700,000	--	12,700,000	47.7%
Logan (1)	1983	1969	10,000,000	--	10,000,000	34.0%
Marion (4)	1983	--	29,930,000	--	29,930,000	35.1%
Berkeley (3)	1984	1974	12,000,000	--	12,000,000	49.6%
Mingo (3)	1984	1979	7,850,000	7,850,000	--	70.6%
Preston (5)	1984	1947	10,735,000	--	10,735,000	35.1%
Wood (3)	1984	1971	3,950,000	3,950,000	--	57.8%
Preston (6)	1985	1947	11,690,000	--	11,690,000	45.3%
Wayne (2)	1985	--	14,300,000	14,300,000	--	53.0%
Ohio (2)	1986	1973	2,300,000	2,300,000	--	68.2%
Preston (7)	1986	1947	15,690,000	--	15,690,000	38.5%
Wetzel (3)	1986	1974	8,900,000	8,900,000	--	61.5%
Berkeley (4)	1987	1974	10,960,000	10,960,000	--	66.0%
Monongalia (3)	1987	1976	29,525,000	--	29,525,000	48.0%
Taylor (4)	1987	1968	6,700,000	6,700,000	--	61.6%

**COUNTY BOARDS OF EDUCATION
BOND ELECTIONS ATTEMPTED SINCE 1971
PRESENTED IN CHRONOLOGICAL ORDER**

County	Year of Bond Election	Previous Issue Passed	Amount of Bond Issue Proposed	Amount of Bond Issue Approved	Amount of Bond Issue Defeated	Percent of Voters For Bond
Hampshire (1)	1988	1962	8,680,000	--	8,680,000	49.0%
Harrison (3)	1988	--	39,700,000	--	39,700,000	42.0%
Marion (5)	1988	--	32,100,000	--	32,100,000	45.0%
Nicholas (2)	1988	1975	8,000,000	8,000,000	--	53.0%
Hampshire (2)	1989	1962	8,680,000	--	8,680,000	23.0%
Jefferson (2)	1989	1974	18,000,000	18,000,000	--	74.1%
Kanawha (2)	1989	1967	103,670,000	--	103,670,000	34.1%
Marion (6)	1989	--	12,330,000	12,330,000	--	55.7%
Mason (4)	1989	1950	18,700,000	--	18,700,000	43.0%
Monongalia (4)	1989	1976	32,500,000	32,500,000	--	62.0%
Preston (8)	1989	1947	8,850,000	8,850,000	--	55.0%
Cabell (2)	1990	1938	45,000,000	45,000,000	--	57.2%
Calhoun (3)	1990	1949	5,375,000	--	5,375,000	40.1%
Calhoun (4)	1990	1949	5,375,000	--	5,375,000	37.1%
Mason (5)	1990	1950	16,300,000	--	16,300,000	32.0%
Mineral (2)	1990	1973	15,300,000	--	15,300,000	36.0%
Mingo (4)	1990	1984	13,000,000	--	13,000,000	33.0%
Mingo (5)	1990	1984	10,970,000	--	10,970,000	38.0%
Tyler (2)	1990	1973	6,200,000	6,200,000	--	63.9%
Wood (4)	1990	1984	9,995,000	9,995,000	--	56.8%
Wood (5)	1990	1990	12,550,000	--	12,550,000	31.2%
Greenbrier (2)	1991	1966	20,200,000	--	20,200,000	26.0%
Harrison (4)	1991	--	37,925,000	37,925,000	--	51.0%
Lincoln (4)	1991	1978	6,375,000	--	6,375,000	38.1%
Logan (2)	1991	1969	23,205,000	--	23,205,000	27.0%
Mason (6)	1991	1950	16,300,000	--	16,300,000	42.0%
Mineral (3)	1991	1973	7,500,000	--	7,500,000	48.0%
Raleigh (3)	1991	1980	30,965,000	--	30,965,000	25.1%
Wirt (2)	1991	1961	1,500,000	1,500,000	--	56.0%
Wood (6)	1991	1990	7,637,000	--	7,637,000	36.3%
Hardy (3)	1992	1977	8,000,000	--	8,000,000	32.0%
Kanawha (3)	1992	1967	73,705,000	--	73,705,000	49.3%
Summers	1992	--	3,300,000	--	3,300,000	46.7%
Wyoming (4)	1992	1959	10,000,000	--	10,000,000	42.0%
Berkeley (5)	1993	1987	42,200,000	--	42,200,000	35.7%
Mingo (6)	1993	1984	27,000,000	--	27,000,000	29.8%
Monroe (2)	1993	1961	3,177,915	--	3,177,915	39.3%
Morgan (4)	1993	1974	7,500,000	--	7,500,000	32.4%
Ohio (3)	1993	1986	14,800,000	14,800,000	--	77.5%
Putnam (4)	1993	1976	39,500,000	--	39,500,000	27.1%
Hardy (4)	1994	1977	3,700,000	3,700,000	--	61.5%
Pocahontas (4)	1994	1968	400,000	--	400,000	25.0%
Roane (3)	1994	1977	3,700,000	3,700,000	--	64.3%
Tucker (2)	1994	1975	6,385,000	--	6,385,000	33.0%
Berkeley (6)	1995	1987	15,950,000	15,950,000	--	56.4%
Kanawha (4)	1995	1967	12,670,000	12,670,000	--	68.3%
Marshall (2)	1995	1974	37,790,000	--	37,790,000	26.7%
Wyoming (5)	1995	1959	14,000,000	--	14,000,000	35.0%
Calhoun (5)	1996	1949	3,370,000	3,370,000	--	50.7%
Greenbrier (3)	1996	1966	8,000,000	8,000,000	--	60.6%
Hancock (3)	1996	1980	12,800,000	--	12,800,000	35.0%
Marion (7)	1996	1989	3,250,000	3,250,000	--	59.3%
Marshall (3)	1996	1974	19,870,000	--	19,870,000	36.8%
McDowell (2)	1996	1974	21,865,000	--	21,865,000	16.0%

**COUNTY BOARDS OF EDUCATION
BOND ELECTIONS ATTEMPTED SINCE 1971
PRESENTED IN CHRONOLOGICAL ORDER**

County	Year of Bond Election	Previous Issue Passed	Amount of Bond Issue Proposed	Amount of Bond Issue Approved	Amount of Bond Issue Defeated	Percent of Voters For Bond
Randolph (2)	1996	1974	19,365,000	--	19,365,000	35.0%
Randolph (3)	1996	1974	19,365,500	--	19,365,500	36.9%
Braxton (3)	1997	1965	11,660,000	--	11,660,000	20.7%
Hampshire (3)	1997	1962	11,060,000	--	11,060,000	43.8%
Hancock (4)	1997	1980	12,500,000	--	12,500,000	27.9%
Kanawha (5)	1997	1995	98,165,000	--	98,165,000	36.9%
Barbour (4)	1998	1979	8,000,000	--	8,000,000	45.8%
Grant (1)	1998	1996	3,500,000	--	3,500,000	49.4%
Hampshire (4)	1998	1962	3,740,000	3,740,000	--	55.1%
Monroe (3)	1998	1961	2,995,000	--	2,995,000	44.0%
Raleigh (4)	1998	1980	14,500,000	14,500,000	--	54.5%
Monroe (4)	1999	1961	2,100,000	2,100,000	--	53.9%
Taylor (5)	1999	1987	9,700,000	--	9,700,000	37.0%
Wayne (3)	1999	--	32,000,000	--	32,000,000	20.0%
Barbour (5)	2000	1979	7,500,000	7,500,000	--	55.4%
Brooke (3)	2000	1981	15,000,000	15,000,000	--	57.7%
Jefferson (3)	2000	1989	39,000,000	--	39,000,000	35.0%
Kanawha (6)	2000	1995	27,505,000	27,505,000	--	59.9%
Marion (8)	2000	1996	29,705,000	--	29,705,000	25.0%
Mason (7)	2000	1950	24,610,000	--	24,610,000	29.0%
Monongalia (5)	2000	1989	80,079,000	--	80,079,000	28.0%
Pleasants (2)	2000	1973	15,000,000	--	15,000,000	28.0%
Wyoming (6)	2000	1959	7,000,000	7,000,000	--	61.0%
Berkeley (7)	2001	1995	27,800,000	27,800,000	--	63.3%
Fayette (2)	2001	1973	39,000,000	--	39,000,000	13.8%
Greenbrier (4)	2001	1996	8,000,000	8,000,000	--	69.0%
Marion (9)	2001	1996	12,000,000	--	12,000,000	42.0%
Mercer (2)	2001	1979	21,900,000	--	21,900,000	14.0%
Mineral (4)	2001	1973	14,950,000	--	14,950,000	36.0%
Putnam (5)	2001	1976	35,850,000	--	35,850,000	25.2%
Taylor (6)	2001	1987	5,120,995	5,120,995	--	77.7%
Hardy (5)	2002	1994	11,970,000	--	11,970,000	46.0%
Lewis (2)	2002	--	8,000,000	--	8,000,000	42.0%
Marion (10)	2002	1996	4,500,000	4,500,000	--	53.8%
Putnam (6)	2002	1976	20,500,000	--	20,500,000	46.5%
Taylor (7)	2002	2001	10,990,000	10,990,000	--	57.5%
Braxton (4)	2003	1965	7,200,000	--	7,200,000	42.7%
Doddridge (2)	2003	1940	8,900,000	8,900,000	--	61.5%
Hardy (6)	2003	1994	11,970,000	--	11,970,000	46.0%
Lewis (3)	2003	--	3,980,000	--	3,980,000	36.7%
Logan (3)	2003	1969	6,500,000	--	6,500,000	48.0%
Monongalia (6)	2003	1989	50,000,000	50,000,000	--	73.2%
Jefferson (4)	2004	1989	19,000,000	19,000,000	--	71.2%
Mason (8)	2004	1950	12,000,000	12,000,000	--	55.0%
Mineral (5)	2004	1973	15,800,000	--	15,800,000	42.0%
Raleigh (5)	2004	1998	13,000,000	13,000,000	--	76.1%
Wood (7)	2004	1990	35,000,000	35,000,000	--	67.2%
Greenbrier (5)	2005	2001	12,500,000	--	12,500,000	25.8%
Hancock (5)	2005	1980	34,000,000	--	34,000,000	28.0%

**COUNTY BOARDS OF EDUCATION
BOND ELECTIONS ATTEMPTED SINCE 1971
PRESENTED IN CHRONOLOGICAL ORDER**

County	Year of Bond Election	Previous Issue Passed	Amount of Bond Issue Proposed	Amount of Bond Issue Approved	Amount of Bond Issue Defeated	Percent of Voters For Bond
Cabell (3)	2006	1990	60,455,000	60,455,000	--	55.4%
Jackson (2)	2006	1959	39,380,000	--	39,380,000	25.1%
Marshall (4)	2006	1974	27,900,000	27,900,000	--	51.0%
Harrison (5)	2007	1991	42,465,000	--	42,465,000	39.2%
Braxton (5)	2008	1965	16,100,000	16,100,000		52.0%
Grant (2)	2008	1996	2,495,500	--	2,495,500	42.0%
Greenbrier (6)	2008	2001	37,745,000	37,745,000		50.8%
Mineral (6)	2008	1973	15,800,000	--	15,800,000	47.9%
Mineral (7)	2008	1973	15,800,000	--	15,800,000	41.6%
Preston (9)	2008	1989	49,995,000	--	49,995,000	49.7%
Berkeley (8)	2009	2001	51,500,000	51,500,000	--	63.6%
Fayette (3)	2009	1973	49,000,000	--	49,000,000	22.6%
Putnam (7)	2009	1976	56,750,000	56,750,000	--	56.0%

NOTE: Percent of votes required for approval of bond levy changed from 60% to 50% by constitutional amendment adopted at the General Election on Nov. 2, 1982.

OSF2
03/05/10
Bonds 09

**COUNTY BOARDS OF EDUCATION
BONDING POTENTIAL
2009-10 YEAR**

County	Taxable Assessed Valuation	Bonding Potential at 5%	Bonds Outstanding June 30, 2009	Unused Potential Remaining
Barbour	\$ 386,854,559	\$ 19,342,728	\$ 960,000	\$ 18,382,728
Berkeley	5,383,735,227	269,186,761	17,385,000	251,801,761
Boone	1,542,656,619	77,132,831	-	77,132,831
Braxton	475,874,786	23,793,739	16,100,000	7,693,739
Brooke	781,251,777	39,062,589	8,430,000	30,632,589
Cabell	3,075,498,031	153,774,902	51,410,000	102,364,902
Calhoun	225,403,767	11,270,188	970,000	10,300,188
Clay	303,903,053	15,195,153	-	15,195,153
Doddridge	413,721,303	20,686,065	6,605,000	14,081,065
Fayette	1,182,028,951	59,101,448	-	59,101,448
Glimer	323,295,117	16,164,756	-	16,164,756
Grant	793,157,092	39,657,855	-	39,657,855
Greenbrier	1,549,881,860	77,494,093	4,980,000	72,514,093
Hampshire	1,397,444,599	69,872,230	--	69,872,230
Hancock	951,823,122	47,591,156	-	47,591,156
Hardy	855,083,702	42,754,185	-	42,754,185
Harrison	2,940,559,273	147,027,964	-	147,027,964
Jackson	1,141,021,177	57,051,059	-	57,051,059
Jefferson	3,922,600,188	196,130,009	16,835,000	179,295,009
Kanawha	8,304,320,731	415,216,037	3,815,000	411,401,037
Lewis	892,835,804	44,641,790	-	44,641,790
Lincoln	486,629,957	24,331,498	-	24,331,498
Logan	1,374,405,537	68,720,277	-	68,720,277
Marion	2,067,992,449	103,399,622	-	103,399,622
Marshall	1,602,411,040	80,120,552	25,065,000	55,055,552
Mason	1,058,513,779	52,925,689	7,625,000	45,300,689
McDowell	945,000,315	47,250,016	-	47,250,016
Mercer	1,508,070,807	75,403,540	-	75,403,540
Mineral	937,646,101	46,882,305	-	46,882,305
Mingo	1,047,850,480	52,392,524	-	52,392,524
Monongalia	3,823,626,714	191,181,336	46,125,000	145,056,336
Monroe	339,998,760	16,999,938	880,000	16,119,938
Morgan	1,076,897,849	53,844,892	-	53,844,892
Nicholas	865,544,731	43,277,237	-	43,277,237
Ohio	1,627,859,099	81,392,955	8,720,000	72,672,955
Pendleton	380,288,435	19,014,422	-	19,014,422
Pleasants	582,537,344	29,126,867	-	29,126,867
Pocahontas	699,584,914	34,979,246	-	34,979,246
Preston	1,126,158,707	56,307,935	-	56,307,935
Putnam	2,650,501,495	132,525,075	-	132,525,075
Raleigh	2,662,074,233	133,103,712	--	133,103,712
Randolph	960,036,514	48,001,826	-	48,001,826
Ritchie	472,887,381	23,644,369	-	23,644,369
Roane	398,961,283	19,948,064	1,605,000	18,343,064
Summers	356,475,938	17,823,797	-	17,823,797
Taylor	535,417,679	26,770,884	8,140,000	18,630,884
Tucker	500,306,035	25,015,302	-	25,015,302
Tyler	365,583,959	18,279,198	-	18,279,198
Upshur	878,075,384	43,903,769	-	43,903,769
Wayne	1,068,492,351	53,424,618	-	53,424,618
Webster	263,511,222	13,175,561	-	13,175,561
Wetzel	616,511,720	30,825,586	-	30,825,586
Wirt	125,936,384	6,296,819	-	6,296,819
Wood	3,096,067,836	154,803,392	28,115,000	126,688,392
Wyoming	947,242,850	47,362,143	3,695,000	43,667,143
Total	\$ 74,292,050,020	\$ 3,714,602,504	\$ 257,460,000	\$ 3,457,142,504

OSF3

03/05/10

Bonding Potential 10

**FINAL COMPUTATIONS (HB 4588 WITH 40% PHASE-IN)
PUBLIC SCHOOL SUPPORT PROGRAM
FOR THE 2009-10 YEAR**

County	Step 1a Basic Allowance Professional Educators (WVC 18-9A-4)	Step 1b Salary Increment For Principals & Assistant Principals (WVC 18-9A-4)	Step 1 Basic Allowance Professional Educators (WVC 18-9A-4)	Step 1 Equity Allowance Professional Educators (WVC 18-9A-4)	Step 1 Total Allowance Professional Educators (WVC 18-9A-4)
Barbour	7,235,169	31,451	7,266,620	697,127	7,963,747
Berkeley	47,073,691	184,634	47,258,325	1,849,970	49,108,295
Boone	13,314,027	72,330	13,386,357	361,849	13,748,206
Braxton	6,881,135	40,169	6,921,304	664,691	7,585,995
Brooke	10,559,540	44,702	10,604,242	390,420	10,994,662
Cabell	35,749,126	133,954	35,883,080	1,815,402	37,698,482
Calhoun	3,464,346	19,012	3,483,358	320,662	3,804,019
Ciay	5,825,275	14,714	5,839,989	508,481	6,348,470
Doddridge	3,646,020	16,746	3,662,766	211,628	3,874,394
Fayette	19,705,119	110,512	19,815,631	1,081,375	20,897,006
Gilmer	2,664,712	20,775	2,685,487	251,756	2,937,242
Grant	5,869,532	24,937	5,894,469	559,426	6,453,895
Greenbrier	15,385,138	61,761	15,446,899	1,095,099	16,541,998
Hampshire	10,373,048	42,737	10,415,785	988,022	11,403,807
Hancock	13,009,413	55,891	13,065,304	47,140	13,112,443
Hardy	6,621,025	24,317	6,645,342	635,776	7,281,118
Harrison	33,704,840	135,705	33,840,545	1,268,400	35,108,945
Jackson	15,121,284	63,665	15,184,949	567,645	15,752,594
Jefferson	22,064,461	86,316	22,150,777	933,877	23,084,654
Kanawha	82,590,628	383,294	82,973,922	1,992,713	84,966,635
Lewis	8,010,097	32,999	8,043,096	617,687	8,660,783
Lincoln	10,684,293	47,419	10,731,712	810,454	11,542,165
Logan	18,224,360	97,011	18,321,371	1,082,362	19,403,733
Marion	23,921,291	96,196	24,017,487	830,439	24,847,926
Marshall	14,969,468	59,948	15,029,416	1,114	15,030,531
Mason	12,455,125	54,600	12,509,725	562,578	13,072,303
McDowell	10,957,593	61,940	11,019,533	699,571	11,719,104
Mercer	27,348,035	117,461	27,465,496	1,618,993	29,084,488
Mineral	13,621,178	65,787	13,686,965	828,161	14,515,127
Mingo	13,398,612	76,708	13,475,320	826,131	14,301,451
Monongalia	29,920,026	105,966	30,025,992	1,256,064	31,282,056
Monroe	5,422,617	20,101	5,442,718	516,245	5,958,963
Morgan	6,769,748	37,418	6,807,166	301,572	7,108,739
Nicholas	12,264,430	56,631	12,321,061	882,083	13,203,144
Ohio	15,654,115	63,411	15,717,526	154,793	15,872,319
Pendleton	3,583,886	13,763	3,597,649	347,776	3,945,425
Pleasants	4,541,533	25,867	4,567,400	37,276	4,604,676
Pocahontas	3,740,056	17,505	3,757,561	358,228	4,115,789
Preston	13,539,187	57,513	13,596,700	1,304,336	14,901,036
Putnam	27,631,408	105,282	27,736,690	215,398	27,952,087
Raleigh	34,796,984	144,107	34,941,091	1,642,266	36,583,357
Randolph	13,676,638	62,135	13,738,773	1,327,574	15,066,348
Ritchie	4,692,561	29,353	4,721,914	459,437	5,181,351
Roane	7,205,824	29,617	7,235,441	668,451	7,903,891
Summers	4,381,882	18,523	4,400,405	420,371	4,820,776
Taylor	7,184,417	22,544	7,206,961	578,508	7,785,468
Tucker	3,438,722	15,221	3,453,943	330,251	3,784,194
Tyler	4,405,745	18,489	4,424,234	281,767	4,706,001
Upshur	11,788,929	51,395	11,840,324	1,136,045	12,976,369
Wayne	21,932,057	96,344	22,028,401	1,337,998	23,366,400
Webster	4,415,578	21,926	4,437,504	423,699	4,861,203
Wetzel	9,113,038	40,810	9,153,848	506,484	9,660,332
Wirt	2,643,040	10,105	2,653,145	160,555	2,813,700
Wood	39,437,568	151,828	39,589,396	1,523,813	41,113,208
Wyoming	12,720,337	64,279	12,784,616	761,233	13,545,849
State	819,347,904	3,557,824	822,905,728	41,051,169	863,956,897

**FINAL COMPUTATIONS (HB 4588 WITH 40% PHASE-IN)
PUBLIC SCHOOL SUPPORT PROGRAM
FOR THE 2009-10 YEAR**

County	Reduction in Step 1 Allowance Due To Reduction in Amount Appropriated	Step 1 Allowance Professional Educators After Reduction in Appropriation	Step 2 Basic Allowance Service Personnel (WVC 18-9A-5)	Step 2 Equity Allowance Service Personnel (WVC 18-9A-5)	Step 2 Total Allowance Service Personnel (WVC 18-9A-5)
Barbour	(212,008)	7,751,739	2,471,728	129,102	2,600,830
Berkeley	(1,307,346)	47,800,949	15,519,792	288,523	15,808,315
Boone	(366,001)	13,382,205	4,525,635	67,768	4,593,403
Braxton	(201,952)	7,384,043	2,246,195	119,322	2,365,516
Brooke	(292,697)	10,701,965	3,376,114	134,698	3,510,812
Cabell	(1,003,598)	36,694,884	12,160,076	357,499	12,517,576
Calhoun	(101,269)	3,702,750	1,190,178	57,115	1,247,293
Clay	(169,007)	6,179,463	1,976,543	105,125	2,081,668
Doddridge	(103,143)	3,771,251	1,217,900	14,426	1,232,325
Fayette	(556,314)	20,340,692	6,562,568	75,938	6,638,506
Gilmer	(78,194)	2,859,048	962,805	50,464	1,013,269
Grant	(171,814)	6,282,081	2,003,493	104,746	2,108,238
Greenbrier	(440,376)	16,101,622	4,990,319	169,776	5,160,095
Hampshire	(303,589)	11,100,218	3,505,856	190,755	3,696,611
Hancock	(349,076)	12,763,367	4,233,967	2,767	4,236,733
Hardy	(193,836)	7,087,282	2,190,234	120,184	2,310,418
Harrison	(934,660)	34,174,285	10,761,038	-	10,761,038
Jackson	(419,361)	15,333,233	5,167,256	96,025	5,263,281
Jefferson	(614,553)	22,470,101	7,497,485	330,740	7,828,225
Kanawha	(2,261,956)	82,704,679	27,011,437	912,881	27,924,318
Lewis	(230,565)	8,430,218	2,615,391	90,548	2,705,940
Lincoln	(307,272)	11,234,893	3,647,182	146,604	3,793,786
Logan	(516,560)	18,887,173	6,305,870	294,595	6,600,464
Marion	(661,494)	24,186,432	7,594,521	-	7,594,521
Marshall	(400,138)	14,630,393	4,522,194	6,235	4,528,429
Mason	(348,007)	12,724,296	4,186,110	139,167	4,325,276
McDowell	(311,982)	11,407,122	3,827,413	49,745	3,877,158
Mercer	(774,278)	28,310,210	9,283,312	229,983	9,513,294
Mineral	(386,417)	14,128,710	4,402,119	208,284	4,610,403
Mingo	(380,729)	13,920,722	4,560,259	178,690	4,738,949
Monongalia	(832,781)	30,449,275	9,799,460	322,044	10,121,504
Monroe	(158,638)	5,800,325	1,851,236	100,998	1,952,234
Morgan	(189,247)	6,919,492	2,541,292	76,878	2,618,170
Nicholas	(351,490)	12,851,654	3,945,591	184,312	4,129,903
Ohio	(422,548)	15,449,771	5,082,318	101,411	5,183,729
Pendleton	(105,034)	3,840,391	1,207,297	61,930	1,269,226
Pleasants	(122,584)	4,482,092	1,366,629	-	1,366,629
Pocahontas	(109,569)	4,006,220	1,348,598	66,594	1,415,192
Preston	(396,691)	14,504,345	4,480,651	236,115	4,716,765
Putnam	(744,132)	27,207,955	8,690,080	-	8,690,080
Raleigh	(973,911)	35,609,446	11,636,059	214,038	11,850,097
Randolph	(401,092)	14,665,256	4,335,876	230,802	4,566,679
Ritchie	(137,936)	5,043,415	1,539,827	81,596	1,621,423
Roane	(210,415)	7,693,476	2,437,624	131,157	2,568,781
Summers	(128,337)	4,692,439	1,514,262	79,870	1,594,132
Taylor	(207,262)	7,578,206	2,345,673	101,578	2,447,251
Tucker	(100,742)	3,683,452	1,219,501	61,754	1,281,255
Tyler	(125,282)	4,580,719	1,412,210	43,202	1,455,412
Upshur	(345,453)	12,630,916	3,759,046	200,460	3,959,506
Wayne	(622,053)	22,744,347	7,097,129	187,314	7,284,443
Webster	(129,413)	4,731,790	1,554,733	80,047	1,634,779
Wetzel	(257,174)	9,403,158	2,869,490	103,192	2,972,682
Wirt	(74,905)	2,738,795	970,451	6,694	977,145
Wood	(1,094,503)	40,018,705	13,040,530	520,619	13,561,149
Wyoming	(360,616)	13,185,233	4,084,795	178,514	4,263,309
State	(23,000,000)	840,956,897	270,645,346	8,042,821	278,688,167

**FINAL COMPUTATIONS (HB 4588 WITH 40% PHASE-IN)
PUBLIC SCHOOL SUPPORT PROGRAM
FOR THE 2009-10 YEAR**

County	Step 3 Allowance for Fixed Charges 8.86% (WVC 18-9A-6)	Step 4 Allowance for Transportation Excluding Allowance For Buses (WVC 18-9A-7)	Step 4 Allowance for Bus Replacement (WVC 18-9A-7)	Step 4 Allowance for Additional Buses (WVC 18-9A-7)	Step 4 Total Allowance for Transportation (WVC 18-9A-7)
Barbour	947,966	518,419	218,750	-	737,169
Berkeley	5,836,337	3,921,925	1,012,400	304,411	5,238,736
Boone	1,640,039	951,130	340,487	73,300	1,364,917
Braxton	889,846	482,103	207,635	-	689,738
Brooke	1,285,185	628,461	158,857	-	787,318
Cabell	4,500,611	1,700,358	685,392	270,900	2,656,650
Calhoun	452,826	335,698	111,942	-	447,640
Clay	753,633	759,922	221,076	-	980,998
Doddridge	457,226	408,732	138,052	-	546,784
Fayette	2,471,181	1,314,074	477,506	-	1,791,580
Gilmer	355,318	176,635	85,429	-	262,064
Grant	765,697	306,918	167,329	-	474,247
Greenbrier	1,953,262	854,332	447,696	-	1,302,028
Hampshire	1,355,272	757,793	358,202	-	1,115,995
Hancock	1,553,600	825,292	245,393	-	1,070,685
Hardy	860,001	443,669	202,154	-	645,823
Harrison	4,113,032	1,294,393	630,382	-	1,924,775
Jackson	1,887,605	764,643	352,067	53,476	1,170,186
Jefferson	2,775,218	1,388,305	549,882	180,600	2,118,787
Kanawha	10,185,990	3,435,962	1,104,286	76,600	4,616,848
Lewis	1,018,685	501,329	247,355	-	748,684
Lincoln	1,371,717	877,116	307,175	165,261	1,349,552
Logan	2,325,464	1,102,818	438,596	76,600	1,618,014
Marion	2,910,853	1,297,779	526,192	76,600	1,900,571
Marshall	1,758,516	816,491	388,226	-	1,204,717
Mason	1,555,030	790,135	369,189	-	1,159,324
McDowell	1,401,908	931,253	346,748	-	1,278,001
Mercer	3,457,482	1,061,218	506,214	84,350	1,651,782
Mineral	1,719,424	1,082,948	369,569	-	1,452,517
Mingo	1,704,262	807,137	339,984	237,550	1,384,671
Monongalia	3,714,935	2,024,583	632,198	74,611	2,731,392
Monroe	708,106	322,552	217,458	-	540,010
Morgan	871,267	435,001	195,817	-	630,818
Nicholas	1,553,334	1,023,953	382,901	-	1,406,854
Ohio	1,888,733	828,564	293,217	-	1,121,781
Pendleton	466,622	299,042	129,251	-	428,293
Pleasants	535,641	226,413	103,091	-	329,504
Pocahontas	497,670	333,419	139,234	-	472,653
Preston	1,755,506	906,730	429,546	-	1,336,276
Putnam	3,287,590	1,431,032	534,628	138,286	2,103,946
Raleigh	4,356,599	2,162,649	814,868	168,700	3,146,217
Randolph	1,765,987	798,394	424,721	-	1,223,115
Ritchie	602,726	365,069	137,559	-	502,628
Roane	936,216	583,485	271,006	76,600	931,091
Summers	578,402	243,223	165,706	-	408,929
Taylor	917,843	361,490	198,236	-	559,726
Tucker	453,215	320,532	105,283	-	425,815
Tyler	552,602	367,845	167,539	-	535,384
Upshur	1,519,679	774,930	316,451	-	1,091,381
Wayne	2,740,563	1,811,884	551,142	90,300	2,453,326
Webster	582,315	409,146	129,944	-	539,090
Wetzel	1,119,285	544,862	183,525	-	728,387
Wirt	341,407	178,789	88,031	-	266,820
Wood	4,909,523	2,116,469	610,919	-	2,727,388
Wyoming	1,577,886	747,143	288,460	-	1,035,603
State	102,496,841	50,154,186	19,064,896	2,148,145	71,367,227

**FINAL COMPUTATIONS (HB 4588 WITH 40% PHASE-IN)
PUBLIC SCHOOL SUPPORT PROGRAM
FOR THE 2009-10 YEAR**

County	Step 5 Basic Allowance for Professional Student Support Personnel (WVC 18-9A-8)	Step 5 Equity Allowance for Professional Student Support Personnel (WVC 18-9A-8)	Step 5 Total Allowance for Professional Student Support Personnel (WVC 18-9A-8)
Barbour	158,420	9,955	168,376
Berkeley	950,362	39,464	989,826
Boone	199,185	3,369	202,554
Braxton	119,379	6,084	125,463
Brooke	55,940	-	55,940
Cabell	588,123	26,353	614,476
Calhoun	89,942	3,211	93,154
Clay	105,018	4,428	109,446
Doddridge	86,082	1,333	87,415
Fayette	371,244	18,247	389,490
Gilmer	90,071	3,346	93,417
Grant	108,693	4,922	113,614
Greenbrier	355,485	21,826	377,310
Hampshire	214,465	15,200	229,665
Hancock	219,249	129	219,378
Hardy	140,705	7,877	148,582
Harrison	566,276	19,787	586,064
Jackson	313,340	9,148	322,488
Jefferson	426,915	16,773	443,688
Kanawha	2,057,141	51,499	2,108,640
Lewis	156,698	7,712	164,410
Lincoln	171,236	8,518	179,754
Logan	265,996	10,141	276,137
Marion	431,991	12,998	444,990
Marshall	322,414	6	322,420
Mason	182,775	4,336	187,111
McDowell	248,117	12,074	260,191
Mercer	439,005	20,270	459,274
Mineral	299,202	15,423	314,626
Mingo	219,058	9,573	228,631
Monongalia	538,296	21,002	559,298
Monroe	109,686	4,851	114,537
Morgan	137,109	3,257	140,367
Nicholas	220,725	11,781	232,505
Ohio	293,621	1,424	295,045
Pendleton	82,855	2,670	85,525
Pleasants	107,801	68	107,869
Pocahontas	114,073	5,552	119,625
Preston	214,330	15,274	229,604
Putnam	494,821	2,565	497,386
Raleigh	734,720	36,931	771,652
Randolph	307,784	24,881	332,665
Ritchie	55,940	-	55,940
Roane	121,906	5,759	127,665
Summers	138,822	8,074	146,896
Taylor	152,670	7,569	160,240
Tucker	81,118	2,296	83,414
Tyler	106,278	2,917	109,195
Upshur	232,664	17,158	249,822
Wayne	300,845	13,744	314,590
Webster	105,411	4,570	109,981
Wetzel	55,940	-	55,940
Wirt	93,599	2,474	96,074
Wood	744,096	27,331	771,428
Wyoming	55,940	-	55,940
State	15,553,577	586,153	16,139,730

**FINAL COMPUTATIONS (HB 4588 WITH 40% PHASE-IN)
PUBLIC SCHOOL SUPPORT PROGRAM
FOR THE 2009-10 YEAR**

County	Step 6a	Step 6b	Step 6c	Step 6d	Step 6
	Allowance for Other Current Expense (WVC 18-9A-9(1))	Allowance for Prof. Personnel Substitute Costs (WVC 18-9A-9(2))	Allowance for Service Personnel Substitute Costs (WVC 18-9A-9(3))	Allowance for Faculty Senates (WVC 18-9A-9(4))	Total Allowance Current Expense, Substitute Costs, & Faculty Senates (WVC 18-9A-9)
Barbour	1,042,907	192,801	62,636	35,000	1,333,344
Berkeley	6,992,088	1,348,938	421,509	250,900	9,013,435
Boone	1,908,059	364,478	116,341	73,700	2,462,578
Braxton	939,180	180,260	57,891	33,650	1,210,981
Brooke	1,415,942	268,603	83,498	51,920	1,819,963
Cabell	5,070,161	961,837	306,868	178,090	6,516,957
Calhoun	468,080	95,826	30,350	16,300	610,555
Clay	816,505	156,803	51,004	28,240	1,052,552
Doddridge	498,733	97,117	30,828	18,800	645,478
Fayette	2,794,133	519,228	169,476	96,400	3,579,237
Gilmer	388,526	71,256	24,414	13,580	497,776
Grant	816,918	161,480	50,819	29,900	1,059,118
Greenbrier	2,160,538	412,255	130,656	77,820	2,781,269
Hampshire	1,519,416	289,268	92,548	51,246	1,952,478
Hancock	1,752,135	338,906	105,816	60,200	2,257,058
Hardy	954,284	176,071	58,310	30,700	1,219,365
Harrison	4,592,128	887,080	275,957	162,922	5,918,087
Jackson	2,067,133	402,949	127,563	74,400	2,672,045
Jefferson	3,461,397	635,782	204,627	116,948	4,418,754
Kanawha	11,570,645	2,219,192	689,806	404,420	14,884,063
Lewis	1,111,077	209,413	67,361	39,840	1,427,692
Lincoln	1,435,616	284,642	90,886	51,900	1,863,044
Logan	2,646,713	490,611	160,359	87,686	3,385,369
Marion	3,431,223	626,675	199,041	120,640	4,377,579
Marshall	2,040,141	384,386	119,870	72,680	2,617,077
Mason	1,753,197	335,780	107,099	63,564	2,259,640
McDowell	1,513,007	289,143	92,516	52,800	1,947,467
Mercer	3,874,996	725,713	233,304	133,240	4,967,253
Mineral	1,893,051	358,767	111,919	64,924	2,428,661
Mingo	1,843,196	359,303	117,293	66,248	2,386,040
Monongalia	4,259,868	802,420	253,053	145,350	5,460,690
Monroe	798,580	151,587	49,001	28,500	1,027,668
Morgan	1,119,680	198,949	65,562	37,460	1,421,651
Nicholas	1,694,508	322,955	102,835	60,700	2,180,999
Ohio	2,191,436	412,743	128,543	75,134	2,807,856
Pendleton	465,331	93,116	30,047	17,024	605,518
Pleasants	562,444	115,234	35,189	22,448	735,315
Pocahontas	484,977	102,361	32,309	18,296	637,943
Preston	1,883,619	359,014	114,556	67,184	2,424,373
Putnam	3,808,175	732,770	228,267	132,900	4,902,113
Raleigh	4,970,180	935,191	298,554	171,300	6,375,225
Randolph	1,809,668	350,676	111,978	62,100	2,334,422
Ritchie	644,637	122,431	39,585	23,800	830,453
Roane	1,043,891	193,344	63,160	34,314	1,334,710
Summers	634,007	118,490	38,750	22,094	813,341
Taylor	1,016,982	185,065	59,407	33,082	1,294,536
Tucker	471,918	91,593	29,961	16,034	609,506
Tyler	623,679	115,069	36,848	22,326	797,923
Upshur	1,579,792	310,405	97,257	55,512	2,042,966
Wayne	3,164,175	604,628	190,019	107,380	4,066,202
Webster	629,271	119,279	38,836	22,150	809,536
Wetzel	1,214,025	227,194	73,079	43,282	1,557,580
Wirt	402,703	76,361	24,900	14,686	518,651
Wood	5,583,070	1,040,433	330,086	189,000	7,142,590
Wyoming	1,799,869	328,248	104,830	62,350	2,295,297
State	115,627,611	21,954,123	6,967,180	4,043,064	148,591,978

**FINAL COMPUTATIONS (HB 4588 WITH 40% PHASE-IN)
PUBLIC SCHOOL SUPPORT PROGRAM
FOR THE 2009-10 YEAR**

County	Step 7a Allowance for Improvement of Instructional Programs (WVC 18-9A-10(1))	Step 7b Allowance for 21st Century Technology Systems (WVC 18-9A-10(2))	Step 7c Allowance For Advanced Placement Programs (WVC 18-9A-10(3))	Step 7 Total Allow for Improvement of Instructional Programs (WVC 18-9A-10)
Barbour	410,854	37,175	919	448,947
Berkeley	1,898,907	254,933	7,418	2,161,258
Boone	627,247	68,873	2,888	699,009
Braxton	384,910	34,096	1,641	420,647
Brooke	507,968	50,680	-	558,648
Cabell	1,418,159	186,331	7,434	1,611,924
Calhoun	267,077	16,831	361	284,270
Clay	354,226	30,194	509	384,928
Doddridge	274,745	17,761	624	293,130
Fayette	848,882	101,326	3,233	953,441
Gilmer	247,178	14,036	476	261,691
Grant	354,329	29,502	706	384,536
Greenbrier	690,401	77,347	2,248	769,996
Hampshire	530,042	54,788	1,904	586,733
Hancock	588,251	64,252	2,560	655,063
Hardy	388,690	34,620	1,428	424,738
Harrison	1,298,594	167,185	5,186	1,470,965
Jackson	667,036	75,456	3,610	746,102
Jefferson	1,015,776	124,742	3,151	1,143,669
Kanawha	3,044,098	418,850	19,102	3,482,050
Lewis	427,904	40,050	1,100	469,054
Lincoln	509,080	53,804	870	563,753
Logan	812,001	96,963	4,152	913,117
Marion	1,008,230	120,858	6,515	1,135,603
Marshall	660,286	72,417	4,874	737,577
Mason	588,520	63,402	3,397	655,319
McDowell	528,435	54,769	1,329	584,533
Mercer	1,119,226	141,662	4,792	1,265,681
Mineral	623,494	67,613	2,921	694,029
Mingo	611,023	69,789	3,282	684,094
Monongalia	1,215,487	153,654	9,042	1,378,183
Monroe	349,745	28,860	1,740	380,345
Morgan	430,056	40,119	1,165	471,340
Nicholas	573,833	60,878	1,690	636,402
Ohio	698,133	78,052	3,774	779,959
Pendleton	266,389	16,405	410	283,204
Pleasants	290,679	20,060	788	311,527
Pocahontas	271,305	17,756	1,182	290,243
Preston	621,135	67,816	2,823	691,774
Putnam	1,102,511	138,604	6,991	1,248,106
Raleigh	1,393,161	181,842	6,170	1,581,174
Randolph	602,637	65,952	2,970	671,559
Ritchie	312,973	23,670	-	336,643
Roane	411,101	37,831	1,116	450,048
Summers	308,579	22,822	295	331,697
Taylor	404,371	36,041	919	441,330
Tucker	268,037	16,796	1,083	285,916
Tyler	305,996	21,953	591	328,540
Upshur	545,140	57,600	3,496	606,236
Wayne	941,434	114,796	3,052	1,059,283
Webster	307,395	22,873	1,034	331,302
Wetzel	456,921	43,510	-	500,431
Wirt	250,726	14,200	1,264	266,189
Wood	1,546,459	200,428	9,223	1,756,110
Wyoming	605,030	62,036	-	667,066
State	37,184,806	4,184,860	159,445	41,529,110

**FINAL COMPUTATIONS (HB 4588 WITH 40% PHASE-IN)
PUBLIC SCHOOL SUPPORT PROGRAM
FOR THE 2009-10 YEAR**

County	Step 8 Total Basic Program Allowance (WVC 18-9A-12)	Step 9 Local Share (WVC 18-9A-11)	Step 10 Basic State Aid Allowance for County Boards (WVC 18-9A-12)
Barbour	13,988,370	2,037,442	11,950,928
Berkeley	86,848,855	23,006,411	63,842,444
Boone	24,344,705	9,345,987	14,998,718
Braxton	13,086,235	2,564,053	10,522,182
Brooke	18,719,831	4,195,212	14,524,619
Cabell	65,113,078	15,318,848	49,794,230
Calhoun	6,838,488	1,227,231	5,611,257
Clay	11,542,690	1,757,175	9,785,515
Doddridge	7,033,610	2,301,573	4,732,037
Fayette	36,164,127	6,327,341	29,836,786
Gilmer	5,342,583	1,845,108	3,497,475
Grant	11,187,532	4,366,878	6,820,654
Greenbrier	28,445,583	6,602,958	21,842,625
Hampshire	20,036,972	6,332,017	13,704,955
Hancock	22,755,884	4,994,321	17,761,563
Hardy	12,696,209	4,115,773	8,580,436
Harrison	58,948,246	15,366,767	43,581,479
Jackson	27,394,941	6,058,605	21,336,336
Jefferson	41,198,442	16,957,462	24,240,980
Kanawha	145,906,587	43,561,547	102,345,040
Lewis	14,964,682	5,034,422	9,930,260
Lincoln	20,356,500	2,730,562	17,625,938
Logan	34,005,738	7,722,823	26,282,915
Marion	42,550,549	10,551,353	31,999,196
Marshall	25,799,128	9,185,486	16,613,642
Mason	22,865,996	5,721,414	17,144,582
McDowell	20,756,380	5,945,580	14,810,800
Mercer	49,624,976	7,746,394	41,878,582
Mineral	25,348,369	3,903,340	21,445,029
Mingo	25,047,369	6,312,098	18,735,271
Monongalia	54,415,277	18,311,468	36,103,809
Monroe	10,523,224	1,595,084	8,928,140
Morgan	13,073,104	4,584,602	8,488,502
Nicholas	22,991,651	4,622,725	18,368,926
Ohio	27,526,874	6,849,161	20,677,713
Pendleton	6,978,779	1,670,263	5,308,516
Pleasants	7,868,577	3,446,349	4,422,228
Pocahontas	7,439,546	3,821,509	3,618,037
Preston	25,658,644	5,607,466	20,051,178
Putnam	47,937,176	11,809,348	36,127,828
Raleigh	63,690,409	12,833,556	50,856,853
Randolph	25,559,682	4,965,408	20,594,274
Ritchie	8,993,228	2,500,350	6,492,878
Roane	14,041,988	2,008,887	12,033,101
Summers	8,565,836	1,802,342	6,763,494
Taylor	13,399,132	2,628,161	10,770,971
Tucker	6,822,572	2,748,265	4,074,307
Tyler	8,359,774	1,970,009	6,389,765
Upshur	22,100,505	4,539,239	17,561,266
Wayne	40,662,754	5,548,873	35,113,881
Webster	8,738,793	1,603,239	7,135,554
Wetzel	16,337,463	3,379,062	12,958,401
Wirt	5,205,081	592,481	4,612,600
Wood	70,886,892	14,997,793	55,889,099
Wyoming	23,080,334	5,875,953	17,204,381
State	1,499,769,950	373,447,774	1,126,322,176

**FINAL COMPUTATIONS (HB 4588 WITH 40% PHASE-IN)
PUBLIC SCHOOL SUPPORT PROGRAM
FOR THE 2009-10 YEAR**

County	Step 10 Basic State Aid Allowance for County Boards Before Mid-Year Reduction (WVC 18-9A-12)	Mid-Year Reduction in Step 1 Allowance Due To Reduction in Amount Appropriated	Step 10 Basic State Aid Allowance for County Boards After Mid-Year Reduction (WVC 18-9A-12)
Barbour	11,950,928	(530,835)	11,420,093
Berkeley	63,842,444	(3,273,387)	60,569,057
Boone	14,998,718	(916,407)	14,082,311
Braxton	10,522,182	(505,656)	10,016,526
Brooke	14,524,619	(732,866)	13,791,753
Cabell	49,794,230	(2,512,849)	47,281,381
Calhoun	5,611,257	(253,563)	5,357,694
Clay	9,785,515	(423,167)	9,362,348
Doddridge	4,732,037	(258,254)	4,473,783
Fayette	29,836,786	(1,392,921)	28,443,865
Gilmer	3,497,475	(195,786)	3,301,689
Grant	6,820,654	(430,194)	6,390,460
Greenbrier	21,842,625	(1,102,632)	20,739,993
Hampshire	13,704,955	(760,138)	12,944,817
Hancock	17,761,563	(874,030)	16,887,533
Hardy	8,580,436	(485,334)	8,095,102
Harrison	43,581,479	(2,340,239)	41,241,240
Jackson	21,336,336	(1,050,013)	20,286,323
Jefferson	24,240,980	(1,538,742)	22,702,238
Kanawha	102,345,040	(5,663,579)	96,681,461
Lewis	9,930,260	(577,298)	9,352,962
Lincoln	17,625,938	(769,360)	16,856,578
Logan	26,282,915	(1,293,385)	24,989,530
Marion	31,999,196	(1,656,276)	30,342,920
Marshall	16,613,642	(1,001,883)	15,611,759
Mason	17,144,582	(871,354)	16,273,228
McDowell	14,810,800	(781,154)	14,029,646
Mercer	41,878,582	(1,938,670)	39,939,912
Mineral	21,445,029	(967,528)	20,477,501
Mingo	18,735,271	(953,285)	17,781,986
Monongalia	36,103,809	(2,085,152)	34,018,657
Monroe	8,928,140	(397,204)	8,530,936
Morgan	8,488,502	(473,844)	8,014,658
Nicholas	18,368,926	(880,075)	17,488,851
Ohio	20,677,713	(1,057,993)	19,619,720
Pendleton	5,308,516	(262,988)	5,045,528
Pleasants	4,422,228	(306,932)	4,115,296
Pocahontas	3,618,037	(274,344)	3,343,693
Preston	20,051,178	(993,251)	19,057,927
Putnam	36,127,828	(1,863,188)	34,264,640
Raleigh	50,856,853	(2,438,519)	48,418,334
Randolph	20,594,274	(1,004,270)	19,590,004
Ritchie	6,492,878	(345,371)	6,147,507
Roane	12,033,101	(526,846)	11,506,255
Summers	6,763,494	(321,336)	6,442,158
Taylor	10,770,971	(518,952)	10,252,019
Tucker	4,074,307	(252,241)	3,822,066
Tyler	6,389,765	(313,686)	6,076,079
Upshur	17,561,266	(864,959)	16,696,307
Wayne	35,113,881	(1,557,522)	33,556,359
Webster	7,135,554	(324,031)	6,811,523
Wetzel	12,958,401	(643,924)	12,314,477
Wirt	4,612,600	(187,551)	4,425,049
Wood	55,889,099	(2,740,462)	53,148,637
Wyoming	17,204,381	(902,918)	16,301,463
State	1,126,322,176	(57,588,344)	1,068,733,832

**FINAL COMPUTATIONS (HB 4588 WITH 40% PHASE-IN)
PUBLIC SCHOOL SUPPORT PROGRAM
ENROLLMENT INFORMATION
FOR THE 2009-10 YEAR**

County	2008-09 2nd Month Headcount Enrollment	FTE Adjust- ments	FTE Enrollment (FTE Basis)	Certified Adults	Net Enr Prior To < 1,400 Adjustment	Adjustments For Net Enrollments < 1,400	Net Enrollment With Total Adjustments
Barbour	2,496	(2.36)	2,493.64	0.50	2,494.14	-	2,494.14
Berkeley	17,214	(177.41)	17,036.59	3.75	17,040.34	-	17,040.34
Boone	4,622	(2.00)	4,620.00	0.50	4,620.50	-	4,620.50
Braxton	2,289	(2.88)	2,286.12	-	2,286.12	-	2,286.12
Brooke	3,423	(26.80)	3,396.20	-	3,396.20	-	3,396.20
Cabell	12,522	(28.90)	12,493.10	3.00	12,496.10	-	12,496.10
Calhoun	1,126	(6.20)	1,119.80	8.75	1,128.55	94.06	1,222.61
Clay	2,026	-	2,026.00	-	2,026.00	-	2,026.00
Doddridge	1,206	(19.60)	1,186.40	2.62	1,189.02	102.07	1,291.09
Fayette	6,810	(32.60)	6,777.40	5.40	6,782.80	-	6,782.80
Gilmer	941	-	941.00	0.82	941.82	136.54	1,078.36
Grant	1,975	-	1,975.00	4.55	1,979.55	-	1,979.55
Greenbrier	5,248	(64.40)	5,183.60	-	5,183.60	-	5,183.60
Hampshire	3,727	(57.50)	3,669.50	-	3,669.50	-	3,669.50
Hancock	4,327	(30.50)	4,296.50	5.75	4,302.25	-	4,302.25
Hardy	2,353	(38.30)	2,314.70	2.15	2,316.85	-	2,316.85
Harrison	11,192	(18.50)	11,173.50	35.05	11,208.55	-	11,208.55
Jackson	5,067	(9.60)	5,057.40	2.05	5,059.45	-	5,059.45
Jefferson	8,398	(38.31)	8,359.69	-	8,359.69	-	8,359.69
Kanawha	28,465	(418.83)	28,046.17	-	28,046.17	-	28,046.17
Lewis	2,686	-	2,686.00	1.33	2,687.33	-	2,687.33
Lincoln	3,606	(3.80)	3,602.20	5.75	3,607.95	-	3,607.95
Logan	6,506	(6.80)	6,499.20	3.45	6,502.65	-	6,502.65
Marion	8,122	(39.40)	8,082.60	12.25	8,094.85	-	8,094.85
Marshall	4,886	(33.66)	4,852.34	-	4,852.34	-	4,852.34
Mason	4,299	(58.50)	4,240.50	-	4,240.50	-	4,240.50
McDowell	3,675	-	3,675.00	-	3,675.00	-	3,675.00
Mercer	9,538	(59.78)	9,478.23	14.52	9,492.75	-	9,492.75
Mineral	4,551	(18.85)	4,532.15	1.25	4,533.40	-	4,533.40
Mingo	4,688	(7.50)	4,680.50	0.85	4,681.35	-	4,681.35
Monongalia	10,294	(12.78)	10,281.22	23.50	10,304.72	-	10,304.72
Monroe	1,955	(23.65)	1,931.35	-	1,931.35	-	1,931.35
Morgan	2,692	-	2,692.00	-	2,692.00	-	2,692.00
Nicholas	4,083	(3.62)	4,079.38	4.25	4,083.63	-	4,083.63
Ohio	5,279	(55.70)	5,223.30	-	5,223.30	-	5,223.30
Pendleton	1,101	(1.80)	1,099.20	1.50	1,100.70	240.10	1,340.80
Pleasants	1,346	-	1,346.00	-	1,346.00	37.86	1,383.86
Pocahontas	1,209	(20.80)	1,188.20	-	1,188.20	211.80	1,400.00
Preston	4,559	(11.20)	4,547.80	1.00	4,548.80	-	4,548.80
Putnam	9,341	(83.75)	9,257.25	33.50	9,290.75	-	9,290.75
Raleigh	12,316	(153.70)	12,162.30	15.05	12,177.35	-	12,177.35
Randolph	4,425	(0.40)	4,424.60	0.75	4,425.35	-	4,425.35
Ritchie	1,589	(3.50)	1,585.50	0.75	1,586.25	-	1,586.25
Roane	2,538	(4.20)	2,533.80	2.19	2,535.99	-	2,535.99
Summers	1,532	(1.50)	1,530.50	-	1,530.50	-	1,530.50
Taylor	2,426	(16.55)	2,409.45	5.90	2,415.35	-	2,415.35
Tucker	1,127	-	1,127.00	-	1,127.00	141.42	1,268.42
Tyler	1,479	(8.90)	1,470.10	1.75	1,471.85	-	1,471.85
Upshur	3,862	(3.60)	3,858.40	6.08	3,864.48	-	3,864.48
Wayne	7,726	(34.20)	7,691.80	-	7,691.80	-	7,691.80
Webster	1,550	(17.00)	1,533.00	-	1,533.00	-	1,533.00
Wetzel	2,920	(14.00)	2,906.00	3.25	2,909.25	-	2,909.25
Wirt	954	(3.00)	951.00	-	951.00	93.59	1,044.59
Wood	13,481	(56.20)	13,424.80	-	13,424.80	-	13,424.80
Wyoming	4,140	(7.80)	4,132.20	32.50	4,164.70	-	4,164.70
State	281,908	(1,740.83)	280,167.17	246.26	280,413.43	1,057.44	281,470.87

OSF
08/04/09
COMPS 10 Final

**FINAL COMPUTATIONS (HB 4588 WITH 40% PHASE-IN)
PUBLIC SCHOOL SUPPORT PROGRAM
PROFESSIONAL EDUCATORS DATA
FOR THE 2009-10 YEAR**

County	Computed State Aid Eligible PE Employed	Student Population Density	Computed No. PE Employed In Excess Of Limits	Computed Number PE Funded/Limits (Not Limited To Employed)	Proration Multi-County Vocational Centers	Computed No. Prof. Educators Chargeable
Barbour	185.98	Low	(6.30)	179.68	1.57	181.25
Berkeley	1,304.70	High	(49.93)	1,254.77	(11.05)	1,243.72
Boone	388.75	Low	(47.97)	340.78	-	340.78
Braxton	181.04	Sparse	(12.41)	168.63	-	168.63
Brooke	275.72	High	(25.10)	250.62	-	250.62
Cabell	930.05	High	(32.98)	897.07	-	897.07
Calhoun	88.70	Sparse	0.74	89.44	(5.82)	83.62
Clay	150.78	Low	(3.89)	146.89	-	146.89
Doddridge	99.30	Sparse	(8.86)	90.44	1.94	92.38
Fayette	511.80	Medium	(28.00)	483.80	-	483.80
Gilmer	73.70	Sparse	(7.44)	66.26	5.82	72.08
Grant	157.30	Sparse	(6.42)	150.88	(4.79)	146.09
Greenbrier	405.89	Low	(23.18)	382.71	-	382.71
Hampshire	267.38	Low	2.03	269.41	-	269.41
Hancock	326.26	High	(9.63)	316.63	-	316.63
Hardy	160.80	Sparse	2.96	163.76	3.10	166.86
Harrison	855.16	High	(28.04)	827.12	(3.25)	823.87
Jackson	390.30	Medium	(15.81)	374.49	(5.22)	369.27
Jefferson	636.44	High	(44.47)	591.97	5.41	597.38
Kanawha	2,113.11	High	(58.63)	2,054.48	-	2,054.48
Lewis	211.10	Low	(15.80)	195.30	2.86	198.16
Lincoln	275.15	Low	(8.93)	266.22	-	266.22
Logan	472.18	Medium	(14.33)	457.85	-	457.85
Marion	627.45	High	(43.61)	583.84	-	583.84
Marshall	381.94	Medium	(24.78)	357.16	-	357.16
Mason	334.34	Low	(20.62)	313.72	-	313.72
McDowell	280.80	Low	(12.29)	268.51	-	268.51
Mercer	699.42	High	(22.99)	676.43	-	676.43
Mineral	343.02	Medium	(9.56)	333.46	-	333.46
Mingo	355.34	Medium	(19.78)	335.56	-	335.56
Monongalia	756.95	High	(9.55)	747.40	-	747.40
Monroe	151.84	Sparse	(10.59)	141.25	-	141.25
Morgan	206.05	Medium	(20.59)	185.46	5.64	191.10
Nicholas	317.70	Low	(16.48)	301.22	-	301.22
Ohio	397.40	High	(12.76)	384.64	-	384.64
Pendleton	90.62	Sparse	(3.52)	87.10	1.69	88.79
Pleasants	122.24	Medium	(14.92)	107.32	(7.05)	100.27
Pocahontas	96.61	Sparse	(1.64)	94.97	-	94.97
Preston	351.87	Low	(16.32)	335.55	-	335.55
Putnam	692.53	High	(10.22)	682.31	-	682.31
Raleigh	898.30	Medium	(28.49)	869.81	-	869.81
Randolph	328.43	Sparse	(2.43)	326.00	-	326.00
Ritchie	128.80	Sparse	(14.25)	114.55	2.67	117.22
Roane	179.87	Low	0.78	180.65	5.22	185.87
Summers	116.53	Sparse	(6.70)	109.83	-	109.83
Taylor	171.61	Medium	0.72	172.33	1.31	173.64
Tucker	85.48	Sparse	(0.07)	85.41	-	85.41
Tyler	117.38	Low	(10.26)	107.12	1.51	108.63
Upshur	295.76	Medium	(6.56)	289.20	(4.43)	284.77
Wayne	564.60	Medium	0.69	565.29	-	565.29
Webster	116.00	Sparse	(5.03)	110.97	-	110.97
Wetzel	230.21	Low	(17.97)	212.24	2.87	215.11
Wirt	76.03	Sparse	(5.16)	70.87	-	70.87
Wood	990.00	High	(21.75)	968.25	-	968.25
Wyoming	331.45	Low	(24.27)	307.18	-	307.18
State	21,298.16	-	(853.36)	20,444.80	-	20,444.80

OSF

06/04/09

COMPS 10 Final

**FINAL COMPUTATIONS (HB 4588 WITH 40% PHASE-IN)
PUBLIC SCHOOL SUPPORT PROGRAM
SERVICE PERSONNEL DATA
FOR THE 2009-10 YEAR**

County	2008-09	Student Population Density	Computed	Computed	Proration Multi-County Vocational Centers	Computed
	State Aid Eligible SP Employed		No. SP Employed In Excess Of Limits	Number Serv Pers Funded		No. Service Personnel Chargeable
Barbour	116.397	Low	(4.134)	112.263	0.286	112.549
Berkeley	886.321	High	(130.852)	755.469	(2.973)	752.496
Boone	238.363	Low	(29.845)	208.518	-	208.518
Braxton	119.323	Sparse	(15.565)	103.758	-	103.758
Brooke	179.142	High	(29.543)	149.599	-	149.599
Cabell	557.255	High	(7.256)	549.999	-	549.999
Calhoun	56.200	Sparse	(1.804)	54.396	(1.455)	52.941
Clay	110.330	Low	(18.917)	91.413	-	91.413
Doddridge	72.192	Sparse	(16.939)	55.253	0.663	55.916
Fayette	351.886	Medium	(48.135)	303.751	-	303.751
Gilmer	47.338	Sparse	(3.582)	43.756	1.455	45.211
Grant	94.100	Sparse	(3.017)	91.083	(1.306)	89.777
Greenbrier	281.295	Low	(47.121)	234.174	-	234.174
Hampshire	191.385	Low	(25.511)	165.874	-	165.874
Hancock	205.770	High	(16.116)	189.654	-	189.654
Hardy	107.875	Sparse	(3.367)	104.508	0.844	105.352
Harrison	518.255	High	(23.657)	494.598	(1.112)	493.486
Jackson	237.697	Medium	(9.067)	228.630	(1.336)	227.294
Jefferson	467.585	High	(100.833)	366.752	1.455	368.207
Kanawha	1,377.985	High	(141.649)	1,236.336	-	1,236.336
Lewis	143.925	Low	(23.193)	120.732	0.521	121.253
Lincoln	173.508	Low	(10.614)	162.894	-	162.894
Logan	303.883	Medium	(16.473)	287.410	-	287.410
Marion	437.930	High	(81.189)	356.741	-	356.741
Marshall	272.070	Medium	(57.228)	214.842	-	214.842
Mason	230.059	Low	(38.105)	191.954	-	191.954
McDowell	215.693	Low	(49.877)	165.816	-	165.816
Mercer	432.954	High	(14.804)	418.150	-	418.150
Mineral	223.636	Medium	(23.044)	200.592	-	200.592
Mingo	254.220	Medium	(43.997)	210.223	-	210.223
Monongalia	495.305	High	(41.759)	453.546	-	453.546
Monroe	107.278	Sparse	(19.453)	87.825	-	87.825
Morgan	128.507	Medium	(11.001)	117.506	1.518	119.024
Nicholas	226.969	Low	(42.657)	184.312	-	184.312
Ohio	250.938	High	(20.550)	230.388	-	230.388
Pendleton	67.270	Sparse	(13.418)	53.852	0.462	54.314
Pleasants	85.920	Medium	(22.850)	63.070	(1.970)	61.100
Pocahontas	74.429	Sparse	(16.522)	57.907	-	57.907
Preston	219.640	Low	(14.323)	205.317	-	205.317
Putnam	430.945	High	(21.823)	409.122	-	409.122
Raleigh	529.917	Medium	5.180	535.097	-	535.097
Randolph	206.813	Sparse	(6.115)	200.698	-	200.698
Ritchie	89.343	Sparse	(18.054)	71.289	0.745	72.034
Roane	127.434	Low	(14.232)	113.202	1.336	114.538
Summers	72.735	Sparse	(3.283)	69.452	-	69.452
Taylor	120.115	Medium	(13.640)	106.475	0.449	106.924
Tucker	57.100	Sparse	(3.401)	53.699	-	53.699
Tyler	81.941	Low	(15.899)	66.042	0.422	66.464
Upshur	179.850	Medium	(5.537)	174.313	(0.807)	173.506
Wayne	402.999	Medium	(62.429)	340.570	-	340.570
Webster	71.998	Sparse	(2.392)	69.606	-	69.606
Wetzel	150.299	Low	(19.485)	130.814	0.803	131.617
Wirt	48.140	Sparse	(3.512)	44.628	-	44.628
Wood	611.108	High	(19.496)	591.612	-	591.612
Wyoming	212.565	Low	(24.605)	187.960	-	187.960
State	13,954.130	-	(1,466.690)	12,487.440	-	12,487.440

OSF
06/04/09
COMPS 10 Final

**FINAL COMPUTATIONS (HB 4588 WITH 40% PHASE-IN)
PUBLIC SCHOOL SUPPORT PROGRAM
PERSONNEL RATIOS PER 1,000 STUDENTS
FOR THE 2009-10 YEAR**

County	Professional Educators		Service Personnel	
	Computed Chargeable Net Enrollment Ratio/1,000	Computed Actual Net Enrollment Ratio/1,000	Computed Chargeable Net Enrollment Ratio/1,000	Computed Actual Net Enrollment Ratio/1,000
Barbour	72.67	72.04	45.13	45.01
Berkeley	72.99	73.64	44.16	44.33
Boone	73.75	73.75	45.13	45.13
Braxton	73.76	73.76	45.39	45.39
Brooke	73.79	73.79	44.05	44.05
Cabell	71.79	71.79	44.01	44.01
Calhoun	68.39	73.15	43.30	44.49
Clay	72.50	72.50	45.12	45.12
Doddridge	71.55	70.05	43.31	42.80
Fayette	71.33	71.33	44.78	44.78
Gilmer	66.84	61.45	41.93	40.58
Grant	73.80	76.22	45.35	46.01
Greenbrier	73.83	73.83	45.18	45.18
Hampshire	73.42	73.42	45.20	45.20
Hancock	73.60	73.60	44.08	44.08
Hardy	72.02	70.68	45.47	45.11
Harrison	73.50	73.79	44.03	44.13
Jackson	72.99	74.02	44.92	45.19
Jefferson	71.46	70.81	44.05	43.87
Kanawha	73.25	73.25	44.08	44.08
Lewis	73.74	72.67	45.12	44.93
Lincoln	73.79	73.79	45.15	45.15
Logan	70.41	70.41	44.20	44.20
Marion	72.12	72.12	44.07	44.07
Marshall	73.61	73.61	44.28	44.28
Mason	73.98	73.98	45.27	45.27
McDowell	73.06	73.06	45.12	45.12
Mercer	71.26	71.26	44.05	44.05
Mineral	73.56	73.56	44.25	44.25
Mingo	71.68	71.68	44.91	44.91
Monongalia	72.53	72.53	44.01	44.01
Monroe	73.14	73.14	45.47	45.47
Morgan	70.99	68.89	44.21	43.65
Nicholas	73.76	73.76	45.13	45.13
Ohio	73.64	73.64	44.11	44.11
Pendleton	66.22	64.96	40.51	40.16
Pleasants	72.46	77.55	44.15	45.58
Pocahontas	67.84	67.84	41.36	41.36
Preston	73.77	73.77	45.14	45.14
Putnam	73.44	73.44	44.04	44.04
Raleigh	71.43	71.43	43.94	43.94
Randolph	73.67	73.67	45.35	45.35
Ritchie	73.90	72.21	45.41	44.94
Roane	73.29	71.23	45.17	44.64
Summers	71.76	71.76	45.38	45.38
Taylor	71.89	71.35	44.27	44.08
Tucker	67.34	67.34	42.34	42.34
Tyler	73.81	72.78	45.16	44.87
Upshur	73.69	74.84	44.90	45.11
Wayne	73.49	73.49	44.28	44.28
Webster	72.39	72.39	45.41	45.41
Wetzel	73.94	72.95	45.24	44.96
Wirt	67.84	67.84	42.72	42.72
Wood	72.12	72.12	44.07	44.07
Wyoming	73.76	73.76	45.13	45.13
State	72.64	72.64	44.36	44.36

**FINAL COMPUTATIONS (HB 4588 WITH 40% PHASE-IN)
PUBLIC SCHOOL SUPPORT PROGRAM
PROFESSIONAL INSTRUCTIONAL PERSONNEL DATA
FOR THE 2009-10 YEAR**

County	2008-09 Net Enrollment With Total Adjustments	Student Population Density	Computed Professional Instructional Employed	Proration Multi-County Vocational Centers	Computed Professional Instructional Chargeable	Computed Professional Instructional Chargeable Ratio/1,000	Computed PI Required	Under PI Limits Without Enrollment Increase
Barbour	2,494.14	Low	172.08	1.29	173.37	69.51	167.73	-
Berkeley	17,040.34	High	1,230.70	(10.20)	1,220.50	71.62	1,151.59	-
Boone	4,620.50	Low	362.50	-	362.50	78.45	316.95	-
Braxton	2,286.12	Sparse	165.95	-	165.95	72.59	155.99	-
Brooke	3,396.20	High	259.60	-	259.60	76.44	249.34	-
Cabell	12,496.10	High	877.05	-	877.05	70.19	830.49	-
Calhoun	1,222.61	Sparse	80.70	(5.40)	75.30	61.59	77.29	-
Clay	2,026.00	Low	139.20	-	139.20	68.71	135.94	-
Doddridge	1,291.09	Sparse	92.40	1.79	94.19	72.95	86.02	-
Fayette	6,782.80	Medium	474.40	-	474.40	69.94	447.76	-
Gilmer	1,078.36	Sparse	66.70	5.40	72.10	66.86	66.28	-
Grant	1,979.55	Sparse	147.50	(4.35)	143.15	72.31	137.53	-
Greenbrier	5,183.60	Low	381.10	-	381.10	73.52	356.44	-
Hampshire	3,669.50	Low	251.83	-	251.83	68.63	249.97	-
Hancock	4,302.25	High	296.60	-	296.60	68.94	296.39	-
Hardy	2,316.85	Sparse	150.70	2.81	153.51	66.26	154.32	-
Harrison	11,208.55	High	801.41	(3.00)	798.41	71.23	767.48	-
Jackson	5,059.45	Medium	364.80	(4.64)	360.16	71.19	341.84	-
Jefferson	8,359.69	High	573.94	4.99	578.93	69.25	553.02	-
Kanawha	28,046.17	High	1,976.86	-	1,976.86	70.49	1,902.35	-
Lewis	2,687.33	Low	195.60	2.34	197.94	73.66	185.91	-
Lincoln	3,607.95	Low	255.70	-	255.70	70.87	250.45	-
Logan	6,502.65	Medium	432.43	-	432.43	66.50	423.68	-
Marion	8,094.85	High	593.20	-	593.20	73.28	540.53	-
Marshall	4,852.34	Medium	356.44	-	356.44	73.46	333.65	-
Mason	4,240.50	Low	311.49	-	311.49	73.46	297.48	-
McDowell	3,675.00	Low	258.80	-	258.80	70.42	248.50	-
Mercer	9,492.75	High	654.72	-	654.72	68.97	626.19	-
Mineral	4,533.40	Medium	318.27	-	318.27	70.21	308.75	-
Mingo	4,681.35	Medium	326.84	-	326.84	69.82	310.57	-
Monongalia	10,304.72	High	714.45	-	714.45	69.33	691.99	-
Monroe	1,931.35	Sparse	139.70	-	139.70	72.33	130.65	-
Morgan	2,692.00	Medium	183.80	5.21	189.01	70.21	176.86	-
Nicholas	4,083.63	Low	298.70	-	298.70	73.15	279.72	-
Ohio	5,223.30	High	369.40	-	369.40	70.72	359.33	-
Pendleton	1,340.80	Sparse	84.12	1.54	85.66	63.89	82.31	-
Pleasants	1,383.86	Medium	110.24	(5.74)	104.50	75.51	93.60	-
Pocahontas	1,400.00	Sparse	89.68	-	89.68	64.06	88.33	-
Preston	4,548.80	Low	331.42	-	331.42	72.86	316.40	-
Putnam	9,290.75	High	652.70	-	652.70	70.25	631.80	-
Raleigh	12,177.35	Medium	841.30	-	841.30	69.09	805.01	-
Randolph	4,425.35	Sparse	304.50	-	304.50	68.81	301.58	-
Ritchie	1,586.25	Sparse	119.00	2.17	121.17	76.39	112.89	-
Roane	2,535.99	Low	169.37	4.64	174.01	68.62	172.04	-
Summers	1,530.50	Sparse	108.07	-	108.07	70.61	101.58	-
Taylor	2,415.35	Medium	162.61	1.21	163.82	67.82	160.72	-
Tucker	1,268.42	Sparse	78.97	-	78.97	62.26	78.93	-
Tyler	1,471.85	Low	109.63	1.23	110.86	75.32	100.71	-
Upshur	3,864.48	Medium	273.16	(3.63)	269.53	69.75	265.03	-
Wayne	7,691.80	Medium	530.10	-	530.10	68.92	530.03	-
Webster	1,533.00	Sparse	108.75	-	108.75	70.94	102.63	-
Wetzel	2,909.25	Low	216.41	2.34	218.75	75.19	210.11	-
Wirt	1,044.59	Sparse	72.03	-	72.03	68.96	65.15	-
Wood	13,424.80	High	927.00	-	927.00	69.05	896.42	-
Wyoming	4,164.70	Low	311.75	-	311.75	74.86	296.08	-
State	385,600.48	-	19,876.37	0.00	19,876.37	51.55	19,020.35	-

OSF

06/04/09

COMPS 10 Final

**FINAL COMPUTATIONS (HB 4588 WITH 40% PHASE-IN)
PUBLIC SCHOOL SUPPORT PROGRAM
PROFESSIONAL EDUCATOR AND PROFESSIONAL
STUDENT SUPPORT PERSONNEL DATA
FOR THE 2009-10 YEAR**

County	Professional Student Support Personnel			Professional Educators			Total Professional Personnel		
	Computed State Aid Eligible Employed	Computed No. Employed In Excess Of Limits	Computed No. Student Support Pers Funded	Computed State Aid Eligible Employed	Computed No. Employed In Excess Of Limits	Computed Adjusted No. Prof Educ. Funded	2008-09 State Aid Eligible Employed	Computed No. Employed In Excess Of Limits	Computed Adjusted No. Prof. Pers. Funded
Barbour	2.92	(0.02)	2.90	185.98	(6.30)	179.68	188.90	(6.32)	182.58
Berkeley	23.80	(1.20)	22.60	1,304.70	(49.93)	1,254.77	1,328.50	(51.13)	1,277.37
Boone	6.00	(1.64)	4.36	388.75	(47.97)	340.78	394.75	(49.61)	345.14
Braxton	2.30	(0.23)	2.07	181.04	(12.41)	168.63	183.34	(12.64)	170.70
Brooke	3.88	(3.88)	-	275.72	(25.10)	250.62	279.60	(28.98)	250.62
Cabell	13.40	0.34	13.74	930.05	(32.98)	897.07	943.45	(32.64)	910.81
Calhoun	0.80	0.50	1.30	88.70	0.74	89.44	89.50	1.24	90.74
Clay	2.00	(0.40)	1.60	150.78	(3.89)	146.89	152.78	(4.29)	148.49
Doddridge	1.60	(0.08)	1.52	99.30	(8.86)	90.44	100.90	(8.94)	91.96
Fayette	7.60	0.28	7.88	511.80	(28.00)	483.80	519.40	(27.72)	491.68
Gilmer	1.20	0.02	1.22	73.70	(7.44)	66.26	74.90	(7.42)	67.48
Grant	2.00	0.03	2.03	157.30	(6.42)	150.88	159.30	(6.39)	152.91
Greenbrier	8.00	(0.33)	7.67	405.89	(23.18)	382.71	413.89	(23.51)	390.38
Hampshire	4.40	0.11	4.51	267.38	2.03	269.41	271.78	2.14	273.92
Hancock	4.40	(0.11)	4.29	326.26	(9.63)	316.63	330.66	(9.74)	320.92
Hardy	2.80	0.17	2.97	160.80	2.96	163.76	163.60	3.13	166.73
Harrison	13.20	(0.30)	12.90	855.16	(28.04)	827.12	868.36	(28.34)	840.02
Jackson	7.20	(0.12)	7.08	390.30	(15.81)	374.49	397.50	(15.93)	381.57
Jefferson	10.80	(0.72)	10.08	636.44	(44.47)	591.97	647.24	(45.19)	602.05
Kanawha	45.24	1.73	46.97	2,113.11	(58.63)	2,054.48	2,158.35	(56.90)	2,101.45
Lewis	3.60	(0.60)	3.00	211.10	(15.80)	195.30	214.70	(16.40)	198.30
Lincoln	3.80	(0.48)	3.32	275.15	(8.93)	266.22	278.95	(9.41)	269.54
Logan	6.00	0.74	6.74	472.18	(14.33)	457.85	478.18	(13.59)	464.59
Marion	10.00	(0.42)	9.58	627.45	(43.61)	583.84	637.45	(44.03)	593.42
Marshall	6.96	(0.12)	6.84	381.94	(24.78)	357.16	388.90	(24.90)	364.00
Mason	6.33	(2.09)	4.24	334.34	(20.62)	313.72	340.67	(22.71)	317.96
McDowell	5.20	0.10	5.30	280.80	(12.29)	268.51	286.00	(12.19)	273.81
Mercer	11.48	(0.70)	10.78	699.42	(22.99)	676.43	710.90	(23.69)	687.21
Mineral	6.35	(0.08)	6.27	343.02	(9.56)	333.46	349.37	(9.64)	339.73
Mingo	4.40	0.28	4.68	355.34	(19.78)	335.56	359.74	(19.50)	340.24
Monongalia	12.30	0.14	12.44	756.95	(9.55)	747.40	769.25	(9.41)	759.84
Monroe	2.80	(0.51)	2.29	151.84	(10.59)	141.25	154.64	(11.10)	143.54
Morgan	3.50	(0.57)	2.93	206.05	(20.59)	185.46	209.55	(21.16)	188.39
Nicholas	4.80	(0.20)	4.60	317.70	(16.48)	301.22	322.50	(16.68)	305.82
Ohio	6.27	(0.06)	6.21	397.40	(12.76)	384.64	403.67	(12.82)	390.85
Pendleton	1.00	0.08	1.08	90.62	(3.52)	87.10	91.62	(3.44)	88.18
Pleasants	2.00	(0.20)	1.80	122.24	(14.92)	107.32	124.24	(15.12)	109.12
Pocahontas	1.80	0.16	1.96	96.61	(1.64)	94.97	98.41	(1.48)	96.93
Preston	4.50	(0.09)	4.41	351.87	(16.32)	335.55	356.37	(16.41)	339.96
Putnam	11.80	(0.22)	11.58	692.53	(10.22)	682.31	704.33	(10.44)	693.89
Raleigh	15.20	0.57	15.77	898.30	(28.49)	869.81	913.50	(27.92)	885.58
Randolph	6.00	0.07	6.07	328.43	(2.43)	326.00	334.43	(2.36)	332.07
Ritchie	1.20	(1.20)	-	128.80	(14.25)	114.55	130.00	(15.45)	114.55
Roane	2.20	0.24	2.44	179.87	0.78	180.65	182.07	1.02	183.09
Summers	2.40	(0.03)	2.37	116.53	(6.70)	109.83	118.93	(6.73)	112.20
Taylor	2.80	0.12	2.92	171.61	0.72	172.33	174.41	0.84	175.25
Tucker	1.20	0.13	1.33	85.48	(0.07)	85.41	86.68	0.06	86.74
Tyler	2.00	(0.15)	1.85	117.38	(10.26)	107.12	119.38	(10.41)	108.97
Upshur	4.40	0.34	4.74	295.76	(6.56)	289.20	300.16	(6.22)	293.94
Wayne	6.80	0.46	7.26	564.60	0.69	565.29	571.40	1.15	572.55
Webster	2.00	(0.02)	1.98	116.00	(5.03)	110.97	118.00	(5.05)	112.95
Wetzel	3.20	(3.20)	-	230.21	(17.97)	212.24	233.41	(21.17)	212.24
Wirt	1.40	0.04	1.44	76.03	(5.16)	70.87	77.43	(5.12)	72.31
Wood	18.00	(1.02)	16.98	990.00	(21.75)	968.25	1,008.00	(22.77)	985.23
Wyoming	4.00	(4.00)	-	331.45	(24.27)	307.18	335.45	(28.27)	307.18
State	351.23	(18.39)	332.84	21,298.16	(853.36)	20,444.80	21,649.39	(871.75)	20,777.64

**COUNTY BOARDS OF EDUCATION
SUMMARY OF PROPOSED BUDGETS
FOR THE 2009-10 YEAR**

County	Current Expense Fund	Special Revenue Fund	Debt Service Fund	Bond Construction Fund	Permanent Improvement Fund	Capital Projects Fund	Total All Funds
Barbour	17,786,337	4,209,311	1,008,000	-	-	-	23,003,648
Berkeley	147,324,388	20,173,240	4,204,684	-	-	-	171,702,312
Boone	43,440,315	7,575,321	-	-	-	-	51,015,636
Braxton	17,388,930	4,923,522	1,209,313	-	-	-	23,521,765
Brooke	29,363,137	4,368,129	1,435,200	400,000	1,357,392	-	36,923,858
Cabell	104,388,290	20,370,602	5,628,963	-	1,373,792	-	131,761,647
Calhoun	7,599,580	2,117,830	348,500	-	-	-	10,065,910
Clay	13,876,485	3,899,500	-	-	-	-	17,775,985
Doddridge	12,342,467	2,132,680	1,132,740	-	-	-	15,607,887
Fayette	61,832,042	11,157,620	-	-	-	-	72,989,662
Gilmer	8,061,730	1,793,080	-	-	-	-	9,854,810
Grant	13,357,194	2,925,770	-	-	-	-	16,282,964
Greenbrier	42,912,540	9,133,130	4,874,820	36,132,600	-	12,129,950	105,183,040
Hampshire	24,993,988	5,577,779	192,170	-	-	-	30,763,937
Hancock	37,459,882	5,372,544	-	-	-	-	42,832,426
Hardy	15,128,380	3,465,340	-	-	-	-	18,593,720
Harrison	101,773,103	16,265,956	-	-	-	-	118,039,059
Jackson	41,247,189	6,185,585	-	-	-	-	47,432,774
Jefferson	79,584,597	10,011,625	3,397,111	-	-	-	92,993,333
Kanawha	231,006,600	44,571,531	3,994,305	75,000	15,000,000	-	294,647,436
Lewis	22,995,743	4,516,362	-	-	-	-	27,512,105
Lincoln	31,909,860	7,681,520	-	-	150,000	-	39,741,380
Logan	58,521,957	10,632,401	-	-	2,765,200	-	71,919,558
Marion	67,576,057	11,128,877	-	-	-	-	78,704,934
Marshall	45,234,001	7,637,938	2,681,175	10,190,000	-	-	65,743,114
Mason	36,290,448	6,442,111	2,049,166	-	-	2,902,722	47,684,447
Mercer	34,287,030	9,396,290	-	-	300,000	-	43,983,320
Mineral	74,018,770	16,227,180	-	-	-	3,490,000	93,735,950
Mingo	37,143,008	7,761,696	-	-	600,000	-	45,504,704
Monongalia	44,050,959	8,667,564	-	-	1,837,342	14,221,230	68,777,095
Monroe	90,474,160	13,361,930	3,401,550	-	4,500,000	-	111,737,640
Morgan	14,362,413	3,313,182	201,898	-	135,351	-	18,012,844
McDowell	22,647,068	3,593,957	-	-	-	405,000	26,646,025
Nicholas	33,341,390	6,264,599	650,000	-	-	-	40,255,989
Ohio	47,205,875	7,641,544	2,921,692	-	1,078,974	-	58,848,085
Pendleton	9,250,973	1,808,677	-	-	-	-	11,059,650
Pleasants	14,212,607	1,951,094	-	-	-	-	16,163,701
Pocahontas	10,425,687	2,207,337	-	-	-	-	12,633,024
Preston	33,831,750	7,114,437	-	-	-	-	40,946,187
Putnam	82,271,363	11,438,907	-	-	-	1,598,950	95,309,220
Raleigh	100,642,309	20,157,891	-	-	1,500,000	700,000	123,000,000
Randolph	32,346,974	7,066,022	-	-	-	-	39,412,996
Ritchie	14,035,555	2,863,585	-	-	-	-	16,899,140
Roane	17,683,584	4,427,271	295,325	-	-	-	22,406,180
Summers	10,851,010	3,596,389	-	-	-	1,360,170	15,807,569
Taylor	18,939,972	3,790,438	934,299	-	-	-	23,664,709
Tucker	9,157,300	1,817,081	-	-	-	-	10,974,381
Tyler	14,044,135	2,559,697	-	-	-	-	16,603,832
Upshur	29,465,211	5,595,422	-	-	-	-	35,060,633
Wayne	59,734,321	11,570,202	-	-	-	-	71,304,523
Webster	10,803,795	3,204,195	-	-	-	-	14,007,990
Wetzel	25,009,587	4,154,362	-	-	-	-	29,163,949
Wirt	7,275,588	1,707,780	-	-	-	232,570	9,215,938
Wood	108,427,410	18,811,870	3,652,450	-	-	723,790	131,615,520
Wyoming	39,372,970	7,630,980	1,433,460	-	777,320	-	49,214,730
Total	2,358,708,014	433,970,682	45,646,821	46,797,600	31,375,371	37,764,382	2,954,262,870

COUNTY BOARDS OF EDUCATION REVENUES BY SOURCE 2008-09

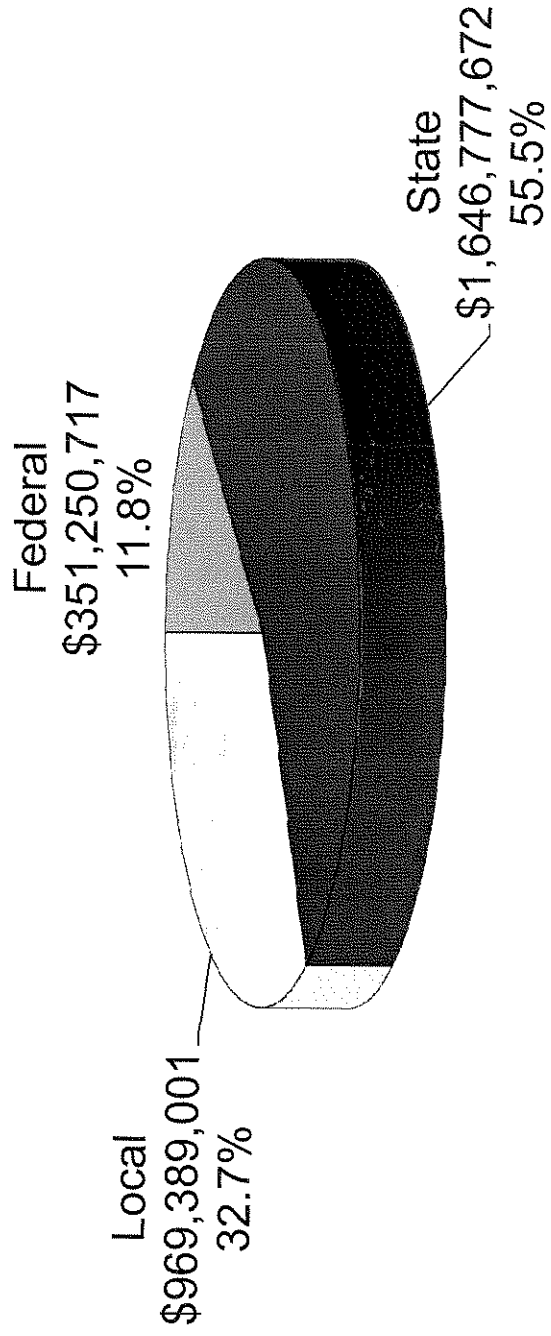

**COUNTY BOARDS OF EDUCATION
TOTAL REVENUES CLASSIFIED BY SOURCE
FOR THE 2008-09 YEAR**

County	Local Revenues		State Revenues		Federal Revenues		Total Revenues
	Amount	Percent	Amount	Percent	Amount	Percent	
Barbour	\$ 3,705,891	14.1%	\$ 19,199,038	72.9%	\$ 3,427,381	13.0%	\$ 26,332,310
Berkeley	70,218,873	40.0%	90,887,630	51.8%	14,502,411	8.3%	175,608,914
Boone	24,101,529	46.5%	21,681,909	41.8%	6,025,573	11.6%	51,809,011
Braxton	4,114,485	18.8%	14,195,624	65.0%	3,541,923	16.2%	21,852,032
Brooke	12,623,250	34.2%	20,781,252	56.3%	3,509,228	9.5%	36,913,730
Cabell	49,634,493	36.5%	70,703,840	52.0%	15,539,135	11.4%	135,877,468
Calhoun	2,122,820	16.9%	8,268,359	65.9%	2,151,073	17.2%	12,542,252
Clay	3,494,239	18.9%	11,889,535	64.3%	3,094,016	16.7%	18,477,790
Doddridge	6,590,497	43.0%	6,850,178	44.7%	1,900,804	12.4%	15,341,479
Fayette	16,976,650	25.5%	41,922,574	62.9%	7,752,390	11.6%	66,651,614
Gilmer	3,508,209	32.5%	5,386,553	49.9%	1,889,327	17.5%	10,784,089
Grant	5,251,781	27.9%	11,083,484	58.8%	2,503,093	13.3%	18,838,358
Greenbrier	15,860,763	28.9%	31,044,881	56.5%	8,042,346	14.6%	54,947,990
Hampshire	8,401,739	25.6%	19,933,475	60.8%	4,467,263	13.6%	32,802,477
Hancock	13,043,797	30.6%	25,570,782	60.0%	4,017,174	9.4%	42,631,753
Hardy	4,640,982	20.6%	15,092,705	66.9%	2,813,189	12.5%	22,546,876
Harrison	39,077,494	33.5%	64,712,814	55.4%	13,025,645	11.2%	116,815,953
Jackson	17,369,556	32.9%	30,214,525	57.2%	5,193,319	9.8%	52,777,400
Jefferson	54,381,389	55.8%	37,497,099	38.5%	5,546,181	5.7%	97,424,669
Kanawha	117,405,065	38.1%	152,825,779	49.6%	38,130,924	12.4%	308,361,768
Lewis	10,197,492	32.5%	17,697,685	56.3%	3,515,665	11.2%	31,410,842
Lincoln	7,795,204	19.8%	24,575,720	62.5%	6,962,945	17.7%	39,333,869
Logan	22,369,882	33.4%	36,573,147	54.6%	8,056,807	12.0%	66,999,836
Marion	26,077,084	32.3%	45,191,612	56.1%	9,346,669	11.6%	80,615,365
Marshall	25,889,235	41.7%	29,902,869	48.2%	6,275,002	10.1%	62,067,106
Mason	16,972,994	34.6%	26,244,388	53.5%	5,824,781	11.9%	49,042,163
McDowell	12,735,959	29.0%	21,615,819	49.2%	9,540,032	21.7%	43,891,810
Mercer	23,013,786	24.2%	58,904,138	62.0%	13,072,344	13.8%	94,990,268
Mineral	11,267,198	24.0%	29,663,022	63.2%	5,997,405	12.8%	46,927,625
Mingo	16,504,923	30.9%	28,806,515	54.0%	8,063,950	15.1%	53,375,388
Monongalia	51,238,492	43.2%	54,489,907	46.0%	12,815,643	10.8%	118,544,042
Monroe	3,549,187	18.1%	12,866,489	65.5%	3,240,432	16.5%	19,656,108
Morgan	10,364,409	40.1%	13,368,604	51.7%	2,139,593	8.3%	25,872,606
Nicholas	9,732,052	23.3%	24,996,514	59.8%	7,060,833	16.9%	41,789,399
Ohio	21,085,044	35.5%	31,485,897	53.1%	6,778,236	11.4%	59,349,177
Pendleton	2,279,612	16.9%	9,959,461	73.7%	1,273,543	9.4%	13,512,616
Pleasants	8,792,386	49.7%	7,461,547	42.1%	1,454,524	8.2%	17,708,457
Pocahontas	4,565,435	35.2%	5,930,629	45.8%	2,462,213	19.0%	12,958,277
Preston	8,787,125	20.9%	27,617,070	65.6%	5,713,199	13.6%	42,117,394
Putnam	34,375,344	36.8%	52,149,172	55.8%	6,851,575	7.3%	93,376,091
Raleigh	40,729,140	33.1%	68,396,689	55.6%	13,970,814	11.3%	123,096,643
Randolph	6,626,738	15.1%	30,995,517	70.6%	6,284,390	14.3%	43,906,645
Ritchie	5,369,982	30.5%	10,551,319	59.9%	1,701,935	9.7%	17,623,236
Roane	3,093,083	13.4%	16,150,232	70.1%	3,786,854	16.4%	23,030,169
Summers	2,383,402	13.1%	13,122,178	72.3%	2,655,441	14.6%	18,161,021
Taylor	5,833,181	24.2%	15,393,685	63.8%	2,887,779	12.0%	24,114,645
Tucker	3,469,723	30.3%	6,137,109	53.5%	1,854,361	16.2%	11,461,193
Tyler	5,453,122	30.9%	10,043,774	56.9%	2,157,147	12.2%	17,654,043
Upshur	8,252,723	21.1%	25,408,808	65.1%	5,362,569	13.7%	39,024,100
Wayne	17,252,797	23.7%	47,020,098	64.5%	8,592,203	11.8%	72,865,098
Webster	2,282,574	11.2%	15,337,798	75.5%	2,706,914	13.3%	20,327,286
Wetzel	8,676,914	27.2%	19,282,116	60.5%	3,936,442	12.3%	31,895,472
Wirt	1,465,329	15.3%	6,513,649	67.8%	1,625,962	16.9%	9,604,940
Wood	41,690,296	31.2%	77,348,295	57.9%	14,474,028	10.8%	133,512,619
Wyoming	16,693,652	34.6%	25,834,164	53.5%	5,736,088	11.9%	48,263,904
Total	\$ 969,389,001	32.7%	\$ 1,646,777,672	55.5%	\$ 351,250,717	11.8%	\$ 2,967,417,386
Bond and capital lease proceeds, not classified above							\$ 8,969,279

Note: RESA funds are not included.

OSF

01/20/10

Revenue Classified by Source 09

**COUNTY BOARDS OF EDUCATION
TOTAL EXPENDITURES
2008-09 YEAR**

County	Current Operations	Capital Outlay	Debt Service	Total
Barbour	22,996,787	1,538,955	1,000,250	25,535,993
Berkeley	163,318,741	2,111,899	4,176,090	169,606,730
Boone	50,778,765	--	--	50,778,765
Braxton	22,486,015	2,346,395	--	24,832,410
Brooke	34,845,188	107,809	1,421,775	36,374,773
Cabell	121,935,294	29,143,955	5,589,463	156,668,711
Calhoun	10,670,396	642,710	343,391	11,656,496
Clay	19,896,863	255,705	--	20,152,568
Doddridge	13,687,114	283,454	767,756	14,738,324
Fayette	69,008,075	5,005,055	--	74,013,129
Gilmer	10,835,823	--	--	10,835,823
Grant	16,990,409	137,120	68,148	17,195,678
Greenbrier	53,433,714	2,133,825	5,150	55,572,689
Hampshire	32,022,467	130,631	480,336	32,633,434
Hancock	42,101,454	212,528	--	42,313,982
Hardy	19,521,321	2,666,806	--	22,188,126
Harrison	111,665,578	2,565,288	--	114,230,866
Jackson	48,262,608	769,034	--	49,031,642
Jefferson	85,333,405	8,819,084	3,377,689	97,530,177
Kanawha	273,205,720	8,005,551	--	281,211,271
Lewis	28,369,520	3,374,076	--	31,743,596
Lincoln	37,780,773	660,958	--	38,441,732
Logan	61,224,403	316,337	--	61,540,740
Marion	81,761,770	199,217	--	81,960,987
Marshall	54,847,556	20,532,015	2,684,588	78,064,159
Mason	45,679,490	2,077,917	1,916,109	49,673,516
McDowell	40,820,595	128,064	--	40,948,659
Mercer	95,507,601	--	--	95,507,601
Mineral	45,983,683	722,746	--	46,706,429
Mingo	48,619,421	4,764,662	--	53,384,084
Monongalia	103,813,197	11,408,862	3,415,800	118,637,860
Monroe	19,837,045	63,411	199,540	20,099,996
Morgan	26,071,322	197,882	--	26,269,204
Nicholas	40,925,140	--	--	40,925,140
Ohio	56,452,277	1,564,958	1,211,194	59,228,429
Pendleton	11,575,350	1,866,304	--	13,441,654
Pleasants	15,908,598	--	--	15,908,598
Pocahontas	12,731,383	--	--	12,731,383
Preston	44,291,699	--	--	44,291,699
Putnam	89,659,257	2,673,078	--	92,332,335
Raleigh	118,706,206	6,192,594	2,860,316	127,759,116
Randolph	41,143,981	3,376,738	--	44,520,719
Ritchie	18,164,906	39,376	--	18,204,283
Roane	22,792,627	--	297,684	23,090,311
Summers	15,371,638	3,327,684	--	18,699,322
Taylor	23,217,804	93,883	931,966	24,243,652
Tucker	11,604,191	74,050	--	11,678,241
Tyler	16,772,561	--	--	16,772,561
Upshur	36,393,988	460,037	--	36,854,025
Wayne	71,454,093	739,293	--	72,193,386
Webster	14,824,576	4,535,694	--	19,360,269
Wetzel	31,450,798	480,837	--	31,931,635
Wirt	9,595,737	25,692	--	9,621,429
Wood	130,455,772	8,513,212	3,141,050	142,110,034
Wyoming	43,685,195	252,259	707,191	44,644,646
State	2,790,489,892	145,537,640	34,595,484	2,970,623,017

Note: Excludes expenditures of Regional Education Service Agencies (RESAs) and Multi-County Vocational Centers (MCCVs).

OSF3

02/18/10

Current Exp by Function 09

**COUNTY BOARDS OF EDUCATION
TOTAL EXPENDITURES - ARRANGED
IN DESCENDING ORDER
2008-09 YEAR**

Ct.	County	Current Operations	Capital Outlay	Debt Service	Total
1.	Kanawha	273,205,720	8,005,551	--	281,211,271
2.	Berkeley	163,318,741	2,111,899	4,176,090	169,606,730
3.	Cabell	121,935,294	29,143,955	5,589,463	156,668,711
4.	Wood	130,455,772	8,513,212	3,141,050	142,110,034
5.	Raleigh	118,706,206	6,192,594	2,860,316	127,759,116
6.	Monongalia	103,813,197	11,408,862	3,415,800	118,637,860
7.	Harrison	111,665,578	2,565,288	--	114,230,866
8.	Jefferson	85,333,405	8,819,084	3,377,689	97,530,177
9.	Mercer	95,507,601	--	--	95,507,601
10.	Putnam	89,659,257	2,673,078	--	92,332,335
11.	Marion	81,761,770	199,217	--	81,960,987
12.	Marshall	54,847,556	20,532,015	2,684,588	78,064,159
13.	Fayette	69,008,075	5,005,055	--	74,013,129
14.	Wayne	71,454,093	739,293	--	72,193,386
15.	Logan	61,224,403	316,337	--	61,540,740
16.	Ohio	56,452,277	1,564,958	1,211,194	59,228,429
17.	Greenbrier	53,433,714	2,133,825	5,150	55,572,689
18.	Mingo	48,619,421	4,764,662	--	53,384,084
19.	Boone	50,778,765	--	--	50,778,765
20.	Mason	45,679,490	2,077,917	1,916,109	49,673,516
21.	Jackson	48,262,608	769,034	--	49,031,642
22.	Mineral	45,983,683	722,746	--	46,706,429
23.	Wyoming	43,685,195	252,259	707,191	44,644,646
24.	Randolph	41,143,981	3,376,738	--	44,520,719
25.	Preston	44,291,699	--	--	44,291,699
26.	Hancock	42,101,454	212,528	--	42,313,982
27.	McDowell	40,820,595	128,064	--	40,948,659
28.	Nicholas	40,925,140	--	--	40,925,140
29.	Lincoln	37,780,773	660,958	--	38,441,732
30.	Upshur	36,393,988	460,037	--	36,854,025
31.	Brooke	34,845,188	107,809	1,421,775	36,374,773
32.	Hampshire	32,022,467	130,631	480,336	32,633,434
33.	Wetzel	31,450,798	480,837	--	31,931,635
34.	Lewis	28,369,520	3,374,076	--	31,743,596
35.	Morgan	26,071,322	197,882	--	26,269,204
36.	Barbour	22,996,787	1,538,955	1,000,250	25,535,993
37.	Braxton	22,486,015	2,346,395	--	24,832,410
38.	Taylor	23,217,804	93,883	931,966	24,243,652
39.	Roane	22,792,627	--	297,684	23,090,311
40.	Hardy	19,521,321	2,666,806	--	22,188,126
41.	Clay	19,896,863	255,705	--	20,152,568
42.	Monroe	19,837,045	63,411	199,540	20,099,996
43.	Webster	14,824,576	4,535,694	--	19,360,269
44.	Summers	15,371,638	3,327,684	--	18,699,322
45.	Ritchie	18,164,906	39,376	--	18,204,283
46.	Grant	16,990,409	137,120	68,148	17,195,678
47.	Tyler	16,772,561	--	--	16,772,561
48.	Pleasants	15,908,598	--	--	15,908,598
49.	Doddridge	13,687,114	283,454	767,756	14,738,324
50.	Pendleton	11,575,350	1,866,304	--	13,441,654
51.	Pocahontas	12,731,383	--	--	12,731,383
52.	Tucker	11,604,191	74,050	--	11,678,241
53.	Calhoun	10,670,396	642,710	343,391	11,656,496
54.	Gilmer	10,835,823	--	--	10,835,823
55.	Wirt	9,595,737	25,692	--	9,621,429
-	State	2,790,489,892	145,537,640	34,595,484	2,970,623,017

Note: Excludes expenditures of Regional Education Service Agencies (RESAs) and Multi-County Vocational Centers (MCCVs).

OSF3

02/18/10

Current Exp by Function 09

COUNTY BOARDS OF EDUCATION EXPENDITURES FOR CURRENT OPERATIONS 2008-09

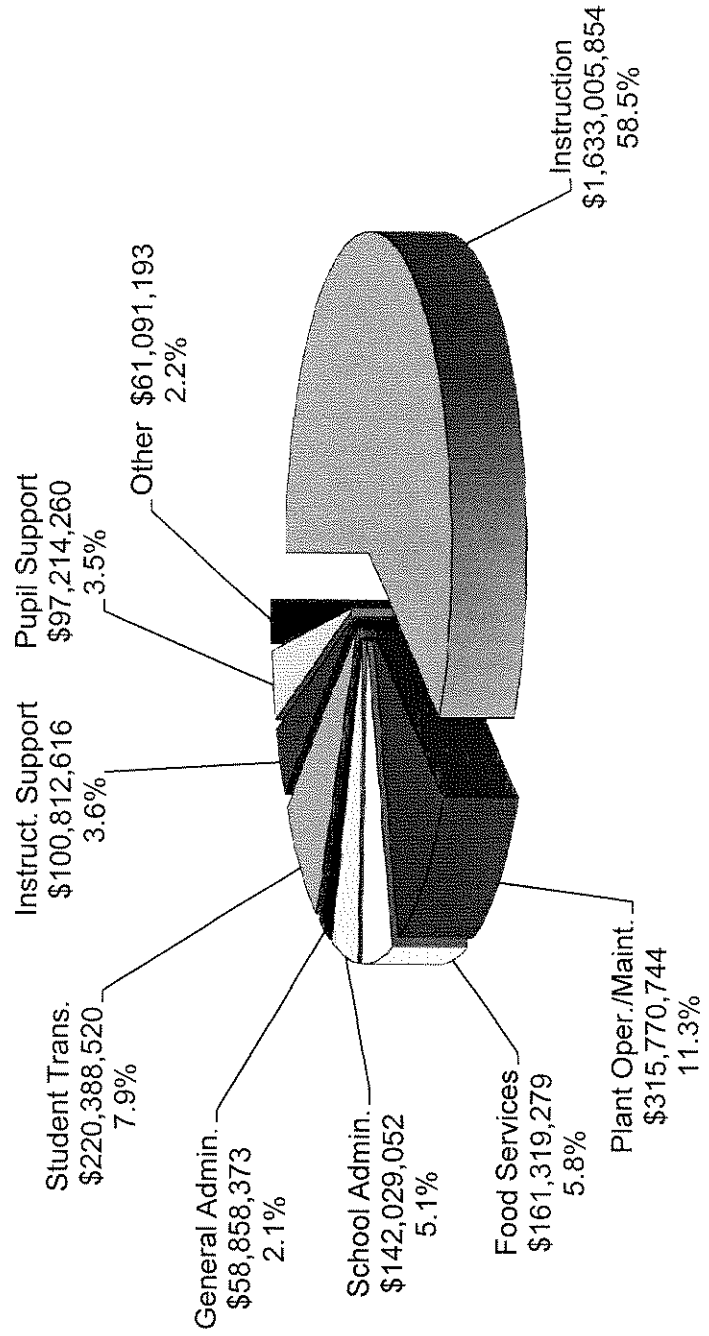

**COUNTY BOARDS OF EDUCATION
EXPENDITURES FOR CURRENT OPERATIONS
CLASSIFIED BY FUNCTION
FOR THE 2008-09 YEAR**

County	Support Services							
	Instruction		Students		Instructional Staff		General Administration	
	Amount	Pct.	Amount	Pct.	Amount	Pct.	Amount	Pct.
Barbour	13,921,946	60.5%	652,323	2.8%	809,891	3.5%	444,136	1.9%
Berkeley	96,299,583	59.0%	6,347,964	3.9%	6,154,108	3.8%	2,178,210	1.3%
Boone	27,477,909	54.1%	1,979,664	3.9%	1,646,460	3.2%	1,827,349	3.6%
Braxton	13,180,148	58.6%	854,945	3.8%	842,924	3.8%	695,077	3.1%
Brooke	20,741,531	59.5%	1,178,937	3.4%	698,893	2.0%	1,394,134	4.0%
Cabell	72,190,807	59.2%	4,791,524	3.9%	5,602,142	4.6%	875,668	0.7%
Calhoun	5,838,812	54.7%	277,450	2.6%	268,115	2.5%	446,966	4.2%
Clay	10,967,822	55.1%	617,432	3.1%	793,046	4.0%	868,394	4.4%
Doddridge	7,132,379	52.1%	396,351	2.9%	839,133	6.1%	602,357	4.4%
Fayette	40,538,201	58.7%	1,799,931	2.6%	2,203,972	3.2%	1,330,815	1.9%
Gilmer	5,555,528	51.3%	407,430	3.8%	412,912	3.8%	441,074	4.1%
Grant	10,250,985	60.3%	543,398	3.2%	730,848	4.3%	522,715	3.1%
Greenbrier	33,114,851	62.0%	958,840	1.8%	1,814,047	3.4%	1,301,717	2.4%
Hampshire	18,390,536	57.4%	1,603,091	5.0%	1,110,779	3.5%	454,515	1.4%
Hancock	24,459,966	58.1%	1,131,625	2.7%	899,224	2.1%	1,966,036	4.7%
Hardy	11,111,327	56.9%	448,631	2.3%	926,190	4.7%	554,887	2.8%
Harrison	62,383,767	55.9%	4,838,161	4.3%	7,079,452	6.3%	1,662,709	1.5%
Jackson	27,598,497	57.2%	2,669,391	5.5%	1,486,949	3.1%	932,319	1.9%
Jefferson	51,612,255	60.5%	3,003,229	3.5%	2,005,005	2.4%	1,941,941	2.3%
Kanawha	161,631,735	59.2%	11,683,514	4.3%	6,945,630	2.5%	2,787,356	1.0%
Lewis	15,510,325	54.7%	1,442,629	5.1%	662,839	2.3%	845,499	3.0%
Lincoln	21,128,612	55.9%	1,295,813	3.4%	2,151,452	5.7%	1,271,569	3.4%
Logan	36,294,674	59.3%	1,623,959	2.7%	2,502,652	4.1%	978,692	1.6%
Marion	50,950,511	62.3%	1,937,241	2.4%	3,565,968	4.4%	1,512,821	1.9%
Marshall	31,779,229	57.9%	1,882,654	3.4%	931,416	1.7%	3,104,606	5.7%
Mason	26,763,792	58.6%	1,940,685	4.3%	1,868,823	4.1%	582,475	1.3%
McDowell	23,087,876	56.6%	478,499	1.2%	2,421,765	5.9%	1,467,252	3.6%
Mercer	55,319,758	57.9%	2,519,669	2.6%	3,693,076	3.9%	814,584	0.9%
Mineral	26,360,473	57.3%	1,900,078	4.1%	1,427,810	3.1%	900,668	2.0%
Mingo	28,305,293	58.2%	1,205,257	2.5%	2,968,002	6.1%	1,687,951	3.5%
Monongalia	60,386,682	58.2%	5,297,120	5.1%	3,812,543	3.7%	1,304,888	1.3%
Monroe	11,238,056	56.7%	686,316	3.5%	435,992	2.2%	734,221	3.7%
Morgan	14,662,571	56.2%	1,062,209	4.1%	1,288,444	4.9%	316,260	1.2%
Nicholas	24,117,609	58.9%	1,247,293	3.1%	1,261,343	3.1%	1,096,597	2.7%
Ohio	33,113,489	58.7%	2,529,135	4.5%	1,957,636	3.5%	1,244,663	2.2%
Pendleton	6,581,961	56.9%	385,640	3.3%	403,962	3.5%	312,603	2.7%
Pleasants	8,597,592	54.0%	574,660	3.6%	397,763	2.5%	663,369	4.2%
Pocahontas	7,164,006	56.3%	328,408	2.6%	333,162	2.6%	745,475	5.9%
Preston	27,848,258	62.9%	1,000,357	2.3%	991,217	2.2%	916,162	2.1%
Putnam	53,873,639	60.1%	2,775,664	3.1%	2,821,238	3.2%	1,344,355	1.5%
Raleigh	64,990,160	54.8%	5,266,320	4.4%	4,533,926	3.8%	2,362,808	2.0%
Randolph	25,156,618	61.1%	1,134,679	2.8%	1,001,220	2.4%	1,236,101	3.0%
Ritchie	9,406,222	51.8%	449,959	2.5%	603,750	3.3%	913,680	5.0%
Roane	13,396,879	58.8%	886,000	3.9%	774,604	3.4%	587,985	2.6%
Summers	8,799,368	57.2%	534,472	3.5%	869,943	5.7%	381,126	2.5%
Taylor	13,078,271	56.3%	870,397	3.8%	601,059	2.6%	926,301	4.0%
Tucker	6,597,460	56.9%	210,715	1.8%	356,842	3.1%	345,262	3.0%
Tyler	9,303,107	55.5%	510,776	3.1%	263,180	1.6%	795,406	4.7%
Upshur	21,635,008	59.5%	1,377,405	3.8%	1,154,270	3.2%	926,031	2.5%
Wayne	42,985,880	60.2%	510,942	0.7%	3,537,918	5.0%	738,582	1.0%
Webster	8,998,346	60.7%	383,376	2.6%	351,781	2.4%	419,582	2.8%
Wetzel	18,045,875	57.4%	1,298,101	4.1%	845,399	2.7%	1,075,725	3.4%
Wirt	5,284,204	55.1%	360,229	3.8%	446,943	4.7%	400,725	4.2%
Wood	81,615,183	62.6%	4,051,594	3.1%	5,187,368	4.0%	1,580,224	1.2%
Wyoming	26,230,282	60.0%	1,072,179	2.5%	1,117,591	2.6%	1,095,753	2.5%
Total	1,633,005,854	58.5%	97,214,260	3.5%	100,812,616	3.6%	58,858,373	2.1%

OSF3
02/18/10
Current Exp by Function 09

**COUNTY BOARDS OF EDUCATION
EXPENDITURES FOR CURRENT OPERATIONS
CLASSIFIED BY FUNCTION
FOR THE 2008-09 YEAR**

Support Services

County	School Administration		Central Services		Oper. & Maint. of Facilities		Student Transportation	
	Amount	Pct.	Amount	Pct.	Amount	Pct.	Amount	Pct.
Barbour	1,138,359	5.0%	279,001	1.2%	2,284,574	9.9%	2,204,567	9.6%
Berkeley	8,812,214	5.4%	3,347,882	2.1%	15,204,430	9.3%	14,907,336	9.1%
Boone	2,652,760	5.2%	1,713,599	3.4%	6,822,802	13.4%	3,631,742	7.2%
Braxton	1,398,930	6.2%	337,298	1.5%	1,955,750	8.7%	2,009,502	8.9%
Brooke	1,972,906	5.7%	332,424	1.0%	4,204,009	12.1%	2,379,638	6.8%
Cabell	5,275,101	4.3%	1,372,039	1.1%	14,262,818	11.7%	8,041,583	6.6%
Calhoun	578,173	5.4%	158,055	1.5%	1,190,167	11.2%	1,260,163	11.8%
Clay	969,100	4.9%	130,064	0.7%	1,659,169	8.3%	2,230,544	11.2%
Doddridge	637,488	4.7%	317,523	2.3%	1,516,610	11.1%	1,467,891	10.7%
Fayette	3,950,513	5.7%	1,756,549	2.6%	8,332,154	12.1%	5,473,806	7.9%
Gilmer	669,075	6.2%	149,040	1.4%	1,723,098	15.9%	834,782	7.7%
Grant	781,969	4.6%	236,414	1.4%	1,288,871	7.6%	1,476,274	8.7%
Greenbrier	2,622,016	4.9%	338,306	0.6%	5,556,831	10.4%	4,498,532	8.4%
Hampshire	1,636,898	5.1%	716,551	2.2%	2,806,047	8.8%	3,495,871	10.9%
Hancock	2,460,872	5.9%	928,082	2.2%	5,183,531	12.3%	3,247,193	7.7%
Hardy	731,022	3.7%	318,703	1.6%	1,939,926	9.9%	1,761,231	9.0%
Harrison	5,885,905	5.3%	2,045,050	1.8%	13,299,739	11.9%	8,088,419	7.2%
Jackson	2,605,582	5.4%	301,930	0.6%	5,917,004	12.3%	4,168,189	8.6%
Jefferson	4,019,509	4.7%	2,271,016	2.7%	8,553,898	10.0%	7,239,414	8.5%
Kanawha	14,196,162	5.2%	6,022,328	2.2%	33,379,576	12.2%	13,878,725	5.1%
Lewis	1,233,845	4.4%	552,267	2.0%	3,710,793	13.1%	2,475,318	8.7%
Lincoln	1,932,352	5.1%	988,394	2.6%	2,980,331	7.9%	3,601,694	9.5%
Logan	3,031,686	5.0%	1,133,603	1.9%	6,661,606	10.9%	5,313,737	8.7%
Marion	3,900,644	4.8%	1,342,719	1.6%	8,657,757	10.6%	5,635,496	6.9%
Marshall	2,868,483	5.2%	1,042,311	1.9%	5,608,866	10.2%	4,650,207	8.5%
Mason	2,286,909	5.0%	528,590	1.2%	5,123,140	11.2%	3,958,091	8.7%
McDowell	2,014,757	4.9%	571,036	1.4%	4,463,255	10.9%	3,968,025	9.7%
Mercer	5,343,735	5.6%	1,477,514	1.6%	13,750,084	14.4%	6,504,963	6.8%
Mineral	2,418,049	5.3%	759,308	1.7%	4,733,225	10.3%	4,597,969	10.0%
Mingo	2,702,768	5.6%	370,851	0.8%	5,245,064	10.8%	3,654,192	7.5%
Monongalia	5,067,954	4.9%	2,292,767	2.2%	11,549,218	11.1%	7,991,513	7.7%
Monroe	889,020	4.5%	246,928	1.2%	2,081,736	10.5%	2,010,183	10.1%
Morgan	1,550,787	6.0%	572,332	2.2%	2,557,911	9.8%	2,410,328	9.3%
Nicholas	1,810,207	4.4%	508,787	1.2%	4,565,765	11.2%	3,914,803	9.6%
Ohio	3,040,988	5.4%	770,774	1.4%	6,758,200	12.0%	3,604,147	6.4%
Pendleton	562,738	4.9%	237,117	2.1%	1,079,140	9.3%	1,286,472	11.1%
Pleasants	904,818	5.7%	446,163	2.8%	1,940,109	12.2%	1,434,857	9.0%
Pocahontas	657,842	5.2%	1,142	0.0%	1,366,942	10.7%	1,450,422	11.4%
Preston	2,007,439	4.5%	462,687	1.0%	4,997,582	11.3%	3,988,446	9.0%
Putnam	5,297,890	5.9%	1,809,565	2.0%	9,446,707	10.5%	6,616,655	7.4%
Raleigh	5,605,229	4.7%	1,610,716	1.4%	16,364,669	13.8%	10,432,566	8.8%
Randolph	2,235,048	5.4%	423,823	1.0%	4,313,119	10.5%	3,089,474	7.5%
Ritchie	912,110	5.0%	142,178	0.8%	3,219,692	17.7%	1,496,594	8.2%
Roane	991,156	4.4%	267,875	1.2%	1,848,501	8.1%	2,508,699	11.0%
Summers	551,181	3.6%	366,860	2.4%	1,316,896	8.6%	1,516,724	9.9%
Taylor	995,137	4.3%	476,573	2.1%	2,747,201	11.8%	2,114,005	9.1%
Tucker	579,737	5.0%	189,372	1.6%	1,602,958	13.8%	1,014,697	8.7%
Tyler	754,442	4.5%	305,982	1.8%	1,913,869	11.4%	1,889,175	11.3%
Upshur	1,873,794	5.2%	343,844	0.9%	3,733,279	10.3%	3,356,945	9.2%
Wayne	3,252,242	4.6%	744,189	1.0%	9,040,125	12.7%	6,241,228	8.7%
Webster	807,327	5.5%	239,970	1.6%	1,312,115	8.9%	1,491,854	10.1%
Wetzel	1,702,385	5.4%	330,308	1.1%	3,975,163	12.6%	2,497,643	7.9%
Wirt	385,231	4.0%	191,589	2.0%	1,060,221	11.1%	889,743	9.3%
Wood	6,481,815	5.0%	2,442,574	1.9%	13,829,497	10.6%	7,280,305	5.6%
Wyoming	2,384,754	5.5%	707,909	1.6%	5,135,007	11.8%	3,205,945	7.3%
Total	142,029,052	5.1%	47,970,476	1.7%	315,770,744	11.3%	220,388,520	7.9%

OSF3
02/18/10
Current Exp by

**COUNTY BOARDS OF EDUCATION
EXPENDITURES FOR CURRENT OPERATIONS
CLASSIFIED BY FUNCTION
FOR THE 2008-09 YEAR**

County	Support Services				Total Expendures Current Operations
	Food Service Operations		Community Service Operations		
	Amount	Pct.	Amount	Pct.	
Barbour	1,261,991	5.5%	-	0.0%	22,996,787
Berkeley	9,286,615	5.7%	780,400	0.5%	163,318,741
Boone	3,024,924	6.0%	1,557	0.0%	50,778,765
Braxton	1,173,299	5.2%	38,141	0.2%	22,486,015
Brooke	1,827,670	5.3%	115,045	0.3%	34,845,188
Cabell	7,818,131	6.4%	1,705,481	1.4%	121,935,294
Calhoun	600,755	5.6%	51,740	0.5%	10,670,396
Clay	1,608,358	8.1%	52,935	0.3%	19,896,863
Doddridge	759,840	5.6%	17,544	0.1%	13,687,114
Fayette	3,586,397	5.2%	35,737	0.1%	69,008,075
Gilmer	617,884	5.7%	25,000	0.2%	10,835,823
Grant	1,158,934	6.8%	-	0.0%	16,990,409
Greenbrier	3,114,872	5.8%	113,702	0.2%	53,433,714
Hampshire	1,808,180	5.7%	-	0.0%	32,022,467
Hancock	1,730,694	4.1%	94,232	0.2%	42,101,454
Hardy	1,488,543	7.6%	240,861	1.2%	19,521,321
Harrison	6,168,514	5.5%	213,861	0.2%	111,665,578
Jackson	2,499,258	5.2%	83,487	0.2%	48,262,608
Jefferson	4,612,138	5.4%	75,000	0.1%	85,333,405
Kanawha	17,994,782	6.6%	4,685,912	1.7%	273,205,720
Lewis	1,838,581	6.5%	97,426	0.3%	28,369,520
Lincoln	2,324,833	6.2%	105,722	0.3%	37,780,773
Logan	3,476,736	5.7%	207,058	0.3%	61,224,403
Marion	4,173,268	5.1%	85,345	0.1%	81,761,770
Marshall	2,920,470	5.3%	59,314	0.1%	54,847,556
Mason	2,586,985	5.7%	40,000	0.1%	45,679,490
McDowell	2,306,791	5.7%	41,339	0.1%	40,820,595
Mercer	5,852,111	6.1%	232,107	0.2%	95,507,601
Mineral	2,820,985	6.1%	65,118	0.1%	45,983,683
Mingo	2,419,952	5.0%	60,091	0.1%	48,619,421
Monongalia	5,462,673	5.3%	647,839	0.6%	103,813,197
Monroe	1,023,511	5.2%	491,081	2.5%	19,837,045
Morgan	1,587,687	6.1%	62,793	0.2%	26,071,322
Nicholas	2,305,814	5.6%	96,921	0.2%	40,925,140
Ohio	2,954,959	5.2%	478,285	0.9%	56,452,277
Pendleton	717,716	6.2%	8,000	0.1%	11,575,350
Pleasants	923,409	5.8%	25,859	0.2%	15,908,598
Pocahontas	663,058	5.2%	20,927	0.2%	12,731,383
Preston	2,070,572	4.7%	8,979	0.0%	44,291,699
Putnam	5,517,723	6.2%	155,821	0.2%	89,659,257
Raleigh	6,864,417	5.8%	675,395	0.6%	118,706,206
Randolph	2,553,899	6.2%	-	0.0%	41,143,981
Ritchie	973,070	5.4%	47,652	0.3%	18,164,906
Roane	1,500,736	6.6%	30,192	0.1%	22,792,627
Summers	936,480	6.1%	98,589	0.6%	15,371,638
Taylor	1,340,956	5.8%	67,905	0.3%	23,217,804
Tucker	707,147	6.1%	-	0.0%	11,604,191
Tyler	1,004,526	6.0%	32,100	0.2%	16,772,561
Upshur	1,805,558	5.0%	187,853	0.5%	36,393,988
Wayne	4,344,655	6.1%	58,333	0.1%	71,454,093
Webster	806,474	5.4%	13,750	0.1%	14,824,576
Wetzel	1,654,513	5.3%	25,688	0.1%	31,450,798
Wirt	575,329	6.0%	1,524	0.0%	9,595,737
Wood	7,497,799	5.8%	489,412	0.4%	130,455,772
Wyoming	2,664,108	6.1%	71,667	0.2%	43,685,195
Total	161,319,279	5.8%	13,120,717	0.5%	2,790,489,892

OSF3
02/18/10
Current Exp b)

**COUNTY BOARDS OF EDUCATION
PER PUPIL EXPENDITURES FOR CURRENT OPERATIONS
FOR THE 2008-09 YEAR**

County	Per Pupil Headcount Enrollment
Barbour	9,179.51
Berkeley	9,292.00
Boone	10,653.62
Braxton	9,710.15
Brooke	10,017.68
Cabell	9,402.21
Calhoun	9,940.07
Clay	9,691.41
Doddridge	11,300.79
Fayette	9,728.01
Gilmer	11,905.65
Grant	8,814.98
Greenbrier	10,013.45
Hampshire	8,445.95
Hancock	9,374.06
Hardy	8,215.34
Harrison	9,887.56
Jackson	9,554.61
Jefferson	10,052.58
Kanawha	9,335.51
Lewis	10,323.41
Lincoln	10,280.37
Logan	9,159.88
Marion	9,897.44
Marshall	11,106.52
Mason	10,411.74
McDowell	10,945.80
Mercer	9,540.92
Mineral	9,883.36
Mingo	10,241.65
Monongalia	9,886.80
Monroe	9,941.53
Morgan	9,568.89
Nicholas	9,885.90
Ohio	10,485.05
Pendleton	10,502.90
Pleasants	11,921.94
Pocahontas	10,438.56
Preston	9,390.54
Putnam	9,303.57
Raleigh	9,069.66
Randolph	8,935.04
Ritchie	10,389.75
Roane	9,048.11
Summers	9,670.00
Taylor	9,295.67
Tucker	10,203.96
Tyler	11,114.33
Upshur	9,412.77
Wayne	9,020.16
Webster	9,440.30
Wetzel	10,588.53
Wirt	9,896.81
Wood	9,474.87
Wyoming	10,461.39
Total	9,675.41

Notes: (a) The methodology used for calculating expenditures on a per pupil basis conforms with the methodology used by the National Center for Education Statistics (NCES). (b) The enrollments used are second month student (headcount) enrollments. (c) All expenditures by county boards are included except those for capital improvements, debt service, community services, adult education and transits/transfers. (d) Also, not included is the portion of the legislative appropriation for the Teachers' Retirement System in excess of the employers' contribution rates of 7.5% or 15%, depending on the retirement plan, which is considered to be the State's annual required contribution towards the past service unfunded liability. (e) RESA expenditures are not included and expenditures of the seven MCVCs are allocated among the 20 county boards served by each MCVC.

OSF
02/02/10
Per Pupil Expenditures 2009

**COUNTY BOARDS OF EDUCATION
EXPENDITURES FOR SALARIES AND EMPLOYEE BENEFITS
FOR THE 2008-09 YEAR**

County	Regular Prof Pers Salaries	Regular Serv Pers Salaries	Substitute Prof Pers Salaries	Substitute Serv Pers Salaries	Temporary Part-time Prof Pers	Temporary Part-time Serv Pers
Barbour	9,927,288	3,020,033	284,696	141,581	-	-
Berkeley	74,263,211	23,468,880	1,960,360	1,324,098	503,025	-
Boone	21,863,243	6,508,077	944,644	627,661	-	-
Braxton	10,293,287	2,996,506	324,461	148,874	-	-
Brooke	15,192,800	4,528,766	535,822	325,864	-	4,740
Cabell	51,954,468	15,321,482	1,553,251	698,268	291,554	386,966
Calhoun	4,833,192	1,599,040	243,133	77,607	39,694	-
Clay	8,551,761	2,877,518	131,739	108,063	15,000	-
Doddridge	5,632,783	1,993,747	242,740	98,894	3,330	-
Fayette	28,957,644	9,178,961	1,356,694	637,318	50,709	13,991
Gilmer	4,207,680	1,253,734	122,770	40,755	16,705	28,240
Grant	7,971,942	2,375,438	369,021	131,554	-	45,784
Greenbrier	22,101,903	7,691,219	1,157,414	647,441	39,747	-
Hampshire	13,400,830	4,487,862	594,266	224,524	15,341	29,787
Hancock	18,728,896	5,675,612	654,021	314,843	82,600	-
Hardy	8,208,350	2,534,771	409,573	145,550	94,807	9,481
Harrison	48,861,185	15,860,138	1,330,578	670,012	82,812	5,729
Jackson	21,761,263	7,052,229	699,816	366,903	34,050	119,861
Jefferson	36,020,158	12,303,798	1,655,887	965,582	-	78,518
Kanawha	124,206,252	37,925,734	3,098,994	1,959,343	1,133,054	1,844,758
Lewis	11,474,647	3,989,301	414,139	269,218	12,675	-
Lincoln	15,094,103	4,703,243	1,043,629	424,422	-	-
Logan	25,631,718	8,864,877	709,722	374,362	170,656	149,702
Marion	34,664,163	11,569,074	1,327,082	761,450	-	-
Marshall	22,433,384	7,616,961	915,576	532,680	-	-
Mason	18,211,266	6,020,798	1,188,055	497,092	279,716	-
McDowell	16,467,248	5,926,128	1,060,506	350,504	53,265	4,403
Mercer	38,518,653	11,639,089	3,058,213	1,174,193	-	-
Mineral	19,405,158	6,481,775	594,471	335,989	45,415	142,488
Mingo	20,228,254	6,343,594	1,164,398	588,203	14,833	126,523
Monongalia	45,014,723	14,215,020	1,541,048	906,076	132,957	183,763
Monroe	8,042,170	3,023,110	320,445	206,555	60,492	17,026
Morgan	10,767,534	3,381,816	314,022	218,144	52,210	16,578
Nicholas	17,795,554	5,675,686	633,542	323,210	101,450	103,562
Ohio	23,946,073	7,333,927	879,445	439,424	6,194	22,248
Pendleton	4,866,133	1,665,746	120,251	60,701	-	4,920
Pleasants	6,926,128	2,415,481	234,341	202,268	-	-
Pocahontas	5,169,385	2,004,931	224,346	92,194	-	-
Preston	19,174,858	5,473,428	666,761	200,119	-	-
Putnam	39,913,748	11,851,957	1,728,819	668,397	173,224	-
Raleigh	49,933,288	14,424,141	2,533,021	1,276,571	40,471	67,583
Randolph	18,320,603	4,915,926	689,668	287,097	3,852	-
Ritchie	7,160,314	2,451,725	213,349	143,778	50,768	-
Roane	9,656,687	3,424,106	387,229	156,152	-	-
Summers	6,621,710	1,964,283	313,792	35,335	22,423	-
Taylor	9,582,907	3,074,315	414,279	225,601	-	9,905
Tucker	4,700,642	1,591,197	176,384	58,846	2,804	-
Tyler	6,881,214	2,203,259	255,077	134,708	-	-
Upshur	16,195,681	4,745,127	533,411	229,296	270	-
Wayne	29,967,733	9,608,609	755,825	746,604	6,088	7,392
Webster	6,506,600	2,046,228	205,875	97,237	-	-
Wetzel	13,307,119	4,017,796	588,261	201,792	-	-
Wirt	4,116,852	1,222,392	202,348	77,679	-	-
Wood	55,602,120	18,365,587	2,640,824	1,227,830	1,011,827	768,796
Wyoming	18,965,431	5,418,619	832,951	425,888	-	-
Total	1,198,201,938	378,322,794	46,550,984	23,604,351	4,644,016	4,192,741

OSF
06/02/10
PersExp09

**COUNTY BOARDS OF EDUCATION
EXPENDITURES FOR SALARIES AND EMPLOYEE BENEFITS
FOR THE 2008-09 YEAR**

County	Board Members Salaries	Students Salaries	Health Insurance	Social Security Contributions	Retirement Contributions	Tuition Reimbursement
Barbour	26,080	12,423	2,961,824	1,032,903	1,358,628	9,712
Berkeley	22,880	9,142	18,792,679	7,591,447	8,659,095	99,878
Boone	38,880	-	4,584,367	2,257,329	2,967,787	15,610
Braxton	29,440	5,904	2,254,630	1,010,908	1,295,565	14,924
Brooke	33,600	4,210	4,200,741	1,520,214	2,166,672	4,726
Cabell	39,360	14,146	13,713,889	5,227,270	6,844,141	23,281
Calhoun	24,480	21,254	1,106,564	502,537	645,527	9,302
Clay	20,960	25,941	1,765,668	860,948	1,114,138	-
Doddridge	22,560	-	1,248,846	588,498	809,667	4,526
Fayette	39,360	-	7,538,397	2,963,704	3,907,819	10,570
Gilmer	33,440	160	990,033	429,164	530,178	10,891
Grant	19,200	8,725	2,123,351	810,122	1,082,585	1,046
Greenbrier	31,040	31,842	6,770,126	2,339,883	3,099,642	3,030
Hampshire	28,800	-	3,809,541	1,385,495	1,785,943	10,232
Hancock	40,160	-	4,598,484	1,899,839	2,644,204	2,127
Hardy	23,680	-	2,136,632	844,911	1,093,293	4,657
Harrison	46,080	-	12,993,385	4,931,639	6,782,444	826
Jackson	31,520	63,768	5,956,383	2,228,927	2,976,215	5,297
Jefferson	34,720	4,153	9,198,911	3,792,996	4,558,902	-
Kanawha	40,000	21,875	31,639,296	12,628,409	16,134,038	7,138
Lewis	30,720	-	3,694,158	1,199,169	1,547,387	2,677
Lincoln	22,080	3,019	4,151,858	1,574,259	2,208,426	4,908
Logan	28,000	-	6,923,928	2,663,207	3,616,581	12,110
Marion	30,240	-	9,828,791	3,611,027	4,484,724	67,226
Marshall	43,680	14,396	7,310,500	2,361,362	3,278,034	-
Mason	36,480	3,706	5,070,252	1,947,553	2,385,374	16,288
McDowell	22,240	-	3,245,716	1,806,355	2,635,038	37,363
Mercer	31,680	-	10,749,036	4,103,706	5,663,398	237,992
Mineral	29,760	7,989	4,901,773	2,005,900	2,866,974	13,860
Mingo	14,720	-	5,167,647	2,137,354	2,713,986	2,790
Monongalia	29,760	-	12,226,695	4,606,721	6,065,250	1,245
Monroe	27,360	32,451	1,944,342	867,873	1,085,303	3,241
Morgan	17,760	5,044	3,050,246	1,094,105	1,314,452	47,093
Nicholas	30,080	(12)	3,944,035	1,820,273	2,460,665	-
Ohio	31,840	-	7,323,438	2,414,733	3,287,371	4,812
Pendleton	16,160	-	1,434,082	489,481	741,660	736
Pleasants	29,440	-	1,860,888	726,230	1,043,225	-
Pocahontas	25,600	-	1,527,559	554,832	763,751	10,625
Preston	30,080	2,481	5,124,734	1,880,796	2,638,521	3,471
Putnam	18,560	-	10,140,350	4,034,813	5,254,180	15,217
Raleigh	33,120	-	10,673,612	5,083,284	6,556,307	75,656
Randolph	37,280	-	4,645,980	1,818,893	2,608,388	38,290
Ritchie	22,240	87,842	1,377,037	748,185	953,931	2,427
Roane	12,320	5,250	2,788,619	999,698	1,389,929	740
Summers	30,240	-	1,856,003	687,729	951,725	12,512
Taylor	37,580	-	2,825,302	982,060	1,421,731	5,889
Tucker	20,160	-	1,081,004	483,502	656,756	2,662
Tyler	22,240	-	1,895,580	699,173	1,056,555	10,312
Upshur	26,720	-	4,459,525	1,609,460	2,247,596	34,012
Wayne	19,360	-	8,579,849	3,034,148	3,834,745	24,360
Webster	17,280	-	1,761,355	657,711	918,230	15,625
Wetzel	23,680	-	3,427,237	1,339,195	1,911,490	4,371
Wirt	17,440	-	971,695	416,402	517,641	5,683
Wood	24,320	42,673	14,229,076	5,981,399	8,129,297	155,349
Wyoming	25,760	-	3,720,471	1,955,143	2,847,631	17,645
Total	1,542,220	428,384	312,296,117	123,242,875	162,512,738	1,124,959

OSF
06/02/10
PersExp09

**COUNTY BOARDS OF EDUCATION
EXPENDITURES FOR SALARIES AND EMPLOYEE BENEFITS
FOR THE 2008-09 YEAR**

County	Unemployment Compensation	Workers Compensation	Other Employee Benefits	Total Salary Expenditures	Total Employee Benefit Expenditures	Total Expenditures
Barbour	5,199	164,216	-	\$ 13,412,101	\$ 5,532,483	\$ 18,944,584
Berkeley	30,648	703,004	224	101,551,597	35,876,974	137,428,571
Boone	7,755	486,557	-	29,982,506	10,319,405	40,301,911
Braxton	2,219	89,028	-	13,798,471	4,667,274	18,465,745
Brooke	851	224,090	-	20,625,803	8,117,295	28,743,098
Cabell	38,820	820,743	-	70,259,495	26,668,144	96,927,639
Calhoun	3,925	53,924	-	6,838,399	2,321,779	9,160,178
Clay	5,923	179,475	-	11,730,982	3,926,153	15,657,135
Doddridge	281	130,737	(973)	7,994,054	2,781,582	10,775,636
Fayette	53,446	768,049	-	40,234,676	15,241,985	55,476,661
Gilmer	4,967	56,239	-	5,703,485	2,021,472	7,724,958
Grant	34,335	111,113	-	10,921,665	4,162,552	15,084,216
Greenbrier	23,943	338,074	-	31,700,607	12,574,698	44,275,305
Hampshire	17,791	194,179	-	18,781,409	7,203,181	25,984,589
Hancock	30,719	274,724	-	25,496,131	9,450,096	34,946,228
Hardy	9,840	97,136	-	11,426,213	4,186,468	15,612,681
Harrison	14,139	937,988	-	66,856,533	25,660,421	92,516,955
Jackson	12,669	385,993	-	30,129,409	11,565,484	41,694,893
Jefferson	70,771	703,962	-	51,062,815	18,325,542	69,388,357
Kanawha	60,440	1,597,810	-	170,230,010	62,067,131	232,297,141
Lewis	3,308	208,092	(2,612)	16,190,700	6,652,179	22,842,879
Lincoln	3,852	444,635	140,163	21,290,496	8,528,101	29,818,597
Logan	23,999	908,921	-	35,929,037	14,148,746	50,077,783
Marion	38,502	487,128	-	48,352,009	18,517,398	66,869,408
Marshall	24,766	309,499	-	31,556,677	13,284,161	44,840,838
Mason	26,639	270,164	1,152	26,237,113	9,717,421	35,954,534
McDowell	43,284	434,406	-	23,884,294	8,202,163	32,086,457
Mercer	9,692	679,066	672,650	54,421,828	22,115,539	76,537,367
Mineral	1,930	240,999	-	27,043,045	10,031,436	37,074,482
Mingo	14,492	670,331	-	28,480,524	10,706,601	39,187,124
Monongalia	2,226	761,651	8,000	62,023,347	23,671,789	85,695,136
Monroe	10,331	114,551	6,878	11,729,608	4,032,519	15,762,128
Morgan	5,648	94,866	-	14,773,108	5,606,410	20,379,518
Nicholas	19,515	296,804	-	24,663,071	8,541,292	33,204,363
Ohio	31,024	391,313	-	32,659,151	13,452,692	46,111,843
Pendleton	48	48,645	-	6,733,911	2,714,651	9,448,562
Pleasants	3,146	90,953	72,782	9,807,657	3,797,225	13,604,881
Pocahontas	876	80,183	-	7,516,456	2,937,826	10,454,282
Preston	1,732	240,361	-	25,547,728	9,889,615	35,437,343
Putnam	11,322	600,994	513,411	54,354,705	20,570,286	74,924,991
Raleigh	24,114	1,314,446	-	68,308,196	23,727,420	92,035,616
Randolph	8,857	317,073	-	24,254,426	9,437,483	33,691,908
Ritchie	265	75,811	103,606	10,130,015	3,261,262	13,391,277
Roane	10,080	115,516	-	13,641,744	5,304,582	18,946,326
Summers	9,372	125,668	-	8,987,782	3,643,008	12,630,790
Taylor	5,275	84,588	-	13,344,587	5,324,845	18,669,432
Tucker	1,719	82,561	985	6,550,032	2,309,188	8,859,221
Tyler	623	72,254	-	9,496,498	3,734,497	13,230,995
Upshur	12,345	238,757	-	21,730,505	8,601,695	30,332,200
Wayne	20,935	590,982	-	41,111,611	16,085,020	57,196,631
Webster	14,641	82,177	-	8,873,221	3,449,738	12,322,959
Wetzel	8,347	195,831	-	18,138,648	6,886,470	25,025,119
Wirt	11,429	54,399	-	5,636,711	1,977,249	7,613,960
Wood	27,334	956,459	240,189	79,683,977	29,719,103	109,403,080
Wyoming	4,948	417,790	-	25,668,649	8,963,627	34,632,277
Total	865,300	20,414,916	1,756,454	\$1,657,487,428	\$622,213,358	\$2,279,700,786

OSF
06/02/10
PersExp09

**COUNTY BOARDS OF EDUCATION
PROFESSIONAL PERSONNEL SUBSTITUTE SALARY EXPENDITURES AS A
PERCENT OF REGULAR PROFESSIONAL PERSONNEL SALARY EXPENDITURES
FOR THE 2008-09 YEAR**

County	Regular Personnel (Object 11)	Substitute Personnel (Object 13)	Percent Substitute of Regular
Barbour	\$ 9,927,288	\$ 284,696	2.9%
Berkeley	74,263,211	1,960,360	2.6%
Boone	21,863,243	944,644	4.3%
Braxton	10,293,287	324,461	3.2%
Brooke	15,192,800	535,822	3.5%
Cabell	51,954,468	1,553,251	3.0%
Calhoun	4,833,192	243,133	5.0%
Clay	8,551,761	131,739	1.5%
Doddridge	5,632,783	242,740	4.3%
Fayette	28,957,644	1,356,694	4.7%
Gilmer	4,207,680	122,770	2.9%
Grant	7,971,942	369,021	4.6%
Greenbrier	22,101,903	1,157,414	5.2%
Hampshire	13,400,830	594,266	4.4%
Hancock	18,728,896	654,021	3.5%
Hardy	8,208,350	409,573	5.0%
Harrison	48,861,185	1,330,578	2.7%
Jackson	21,761,263	699,816	3.2%
Jefferson	36,020,158	1,655,887	4.6%
Kanawha	124,206,252	3,098,994	2.5%
Lewis	11,474,647	414,139	3.6%
Lincoln	15,094,103	1,043,629	6.9%
Logan	25,631,718	709,722	2.8%
Marion	34,664,163	1,327,082	3.8%
Marshall	22,433,384	915,576	4.1%
Mason	18,211,266	1,188,055	6.5%
McDowell	16,467,248	1,060,506	6.4%
Mercer	38,518,653	3,058,213	7.9%
Mineral	19,405,158	594,471	3.1%
Mingo	20,228,254	1,164,398	5.8%
Monongalia	45,014,723	1,541,048	3.4%
Monroe	8,042,170	320,445	4.0%
Morgan	10,767,534	314,022	2.9%
Nicholas	17,795,554	633,542	3.6%
Ohio	23,946,073	879,445	3.7%
Pendleton	4,866,133	120,251	2.5%
Pleasants	6,926,128	234,341	3.4%
Pocahontas	5,169,385	224,346	4.3%
Preston	19,174,858	666,761	3.5%
Putnam	39,913,748	1,728,819	4.3%
Raleigh	49,933,288	2,533,021	5.1%
Randolph	18,320,803	689,668	3.8%
Ritchie	7,160,314	213,349	3.0%
Roane	9,656,687	387,229	4.0%
Summers	6,621,710	313,792	4.7%
Taylor	9,582,907	414,279	4.3%
Tucker	4,700,642	176,384	3.8%
Tyler	6,881,214	255,077	3.7%
Upshur	16,195,681	533,411	3.3%
Wayne	29,967,733	755,825	2.5%
Webster	6,506,600	205,875	3.2%
Wetzel	13,307,119	588,261	4.4%
Wirt	4,116,852	202,348	4.9%
Wood	55,602,120	2,640,824	4.7%
Wyoming	18,965,431	832,951	4.4%
Total	\$ 1,198,201,938	\$ 46,550,984	3.9%

Note: Does not include RESA expenditures.

OSF2
06/02/10
Salary and Sub Expenditures 09

**COUNTY BOARDS OF EDUCATION
SERVICE PERSONNEL SUBSTITUTE SALARY EXPENDITURES AS A
PERCENT OF REGULAR SERVICE PERSONNEL SALARY EXPENDITURES
FOR THE 2008-09 YEAR**

County	Regular Personnel (Object 12)	Substitute Personnel (Object 14)	Percent Substitute of Regular
Barbour	\$ 3,020,033	\$ 141,581	4.7%
Berkeley	23,468,880	1,324,098	5.6%
Boone	6,508,077	627,661	9.6%
Braxton	2,996,506	148,874	5.0%
Brooke	4,528,766	325,864	7.2%
Cabell	15,321,482	698,268	4.6%
Calhoun	1,599,040	77,607	4.9%
Clay	2,877,518	108,063	3.8%
Doddridge	1,993,747	98,894	5.0%
Fayette	9,178,961	637,318	6.9%
Gilmer	1,253,734	40,755	3.3%
Grant	2,375,438	131,554	5.5%
Greenbrier	7,691,219	647,441	8.4%
Hampshire	4,487,862	224,524	5.0%
Hancock	5,675,612	314,843	5.5%
Hardy	2,534,771	145,550	5.7%
Harrison	15,860,138	670,012	4.2%
Jackson	7,052,229	366,903	5.2%
Jefferson	12,303,798	965,582	7.8%
Kanawha	37,925,734	1,959,343	5.2%
Lewis	3,989,301	269,218	6.7%
Lincoln	4,703,243	424,422	9.0%
Logan	8,864,877	374,362	4.2%
Marion	11,569,074	761,450	6.6%
Marshall	7,616,961	532,680	7.0%
Mason	6,020,798	497,092	8.3%
McDowell	5,926,128	350,504	5.9%
Mercer	11,639,089	1,174,193	10.1%
Mineral	6,481,775	335,989	5.2%
Mingo	6,343,594	588,203	9.3%
Monongalia	14,215,020	906,076	6.4%
Monroe	3,023,110	206,555	6.8%
Morgan	3,381,816	218,144	6.5%
Nicholas	5,675,686	323,210	5.7%
Ohio	7,333,927	439,424	6.0%
Pendleton	1,665,746	60,701	3.6%
Pleasants	2,415,481	202,268	8.4%
Pocahontas	2,004,931	92,194	4.6%
Preston	5,473,428	200,119	3.7%
Putnam	11,851,957	668,397	5.6%
Raleigh	14,424,141	1,276,571	8.9%
Randolph	4,915,926	287,097	5.8%
Ritchie	2,451,725	143,778	5.9%
Roane	3,424,106	156,152	4.6%
Summers	1,964,283	35,335	1.8%
Taylor	3,074,315	225,601	7.3%
Tucker	1,591,197	58,846	3.7%
Tyler	2,203,259	134,708	6.1%
Upshur	4,745,127	229,296	4.8%
Wayne	9,608,609	746,604	7.8%
Webster	2,046,228	97,237	4.8%
Wetzel	4,017,796	201,792	5.0%
Wirt	1,222,392	77,679	6.4%
Wood	18,365,587	1,227,830	6.7%
Wyoming	5,418,619	425,888	7.9%
Total	\$ 378,322,794	\$ 23,604,351	6.2%

Note: Does not include RESA expenditures.

OSF2

06/02/10

Salary and Sub Expenditures 09

**COUNTY BOARDS OF EDUCATION
EXPENDITURES FOR INSTRUCTIONAL SUPPLIES
2008-09 YEAR**

County	General Supplies	Textbooks, Books and Periodicals	Technology-Related Supplies	Miscellaneous Supplies	Total
Barbour	228,846	231,385	196,691	-	656,922
Berkeley	2,382,078	2,662,163	50,684	19,564	5,114,489
Boone	791,967	754,545	341,812	6,778	1,895,101
Braxton	262,259	281,548	410,604	-	954,411
Brooke	596,125	300,301	37,696	-	934,122
Cabell	4,994,117	1,214,503	1,281,048	27	7,489,694
Calhoun	215,887	156,532	51,054	1,176	424,648
Clay	617,460	132,339	0	-	749,799
Doddridge	170,576	153,179	11,719	-	335,474
Fayette	999,536	1,072,628	618,386	678	2,691,227
Gilmer	290,284	68,627	8,676	-	367,587
Grant	190,179	247,542	87,906	-	525,627
Greenbrier	576,863	731,731	6,550	2,362	1,317,507
Hampshire	745,469	130,341	4,021	5,121	884,951
Hancock	348,544	129,060	299,627	-	777,231
Hardy	268,516	45,887	10,385	-	324,787
Harrison	2,102,833	1,389,733	1,011,684	1,030	4,505,279
Jackson	737,556	395,010	36,459	2,935	1,171,961
Jefferson	1,481,722	1,077,462	223,315	7,663	2,790,162
Kanawha	2,652,421	2,460,204	3,607,835	3,201	8,723,660
Lewis	463,409	380,022	290,714	3,482	1,137,627
Lincoln	692,985	368,592	110,098	-	1,171,675
Logan	945,561	537,647	207,865	64,668	1,755,741
Marion	1,999,966	881,799	1,538,423	-	4,420,188
Marshall	752,215	298,074	-26,755	-	1,023,534
Mason	1,009,890	666,139	252,207	-	1,928,236
McDowell	849,203	569,425	365,358	-	1,783,986
Mercer	1,428,342	1,135,724	118,602	626	2,683,294
Mineral	655,938	417,137	120,384	-	1,193,459
Mingo	448,786	891,181	207,489	-	1,547,455
Monongalia	1,126,921	1,107,775	6,902	-	2,241,598
Monroe	395,982	165,995	217,127	320	779,424
Morgan	323,047	417,980	134,154	15	875,196
Nicholas	582,172	311,941	27,535	2,334	923,982
Ohio	825,059	211,668	0	-	1,036,726
Pendleton	118,011	70,102	43,114	162	231,390
Pleasants	327,241	122,758	189,682	828	640,509
Pocahontas	163,820	91,709	37,860	1,735	295,124
Preston	775,899	502,088	188,585	897	1,467,469
Putnam	1,007,287	1,295,782	149,941	15,749	2,468,758
Raleigh	1,164,749	1,121,832	81,465	22,703	2,390,749
Randolph	325,333	373,530	192,005	-	890,868
Ritchie	212,618	142,294	123,064	300	478,275
Roane	234,153	229,074	7,273	336	470,836
Summers	147,683	144,351	36,202	1,713	329,949
Taylor	247,781	251,718	99,820	-	599,318
Tucker	225,231	90,263	62,856	-	378,351
Tyler	317,938	164,326	85,819	-	568,083
Upshur	535,783	343,281	303,101	-	1,182,165
Wayne	717,810	788,871	72,358	5,423	1,584,462
Webster	289,056	155,942	14,385	-	459,382
Wetzel	439,301	171,194	319,295	1,654	931,444
Wirt	146,290	109,389	12,989	-	268,668
Wood	1,742,611	1,441,856	104,126	40	3,288,632
Wyoming	1,237,890	914,831	58,517	4,650	2,215,887
Total	43,529,197	30,521,006	14,048,711	178,167	88,277,081

Note: RESA expenditures are not included.

OSF3
06/03/10
Instructional supplies 09

**COUNTY BOARDS OF EDUCATION
TOTAL EXPENDITURES - ARRANGED
IN DESCENDING ORDER
2008-09 YEAR**

Ct.	County	Current Operations	Capital Outlay	Debt Service	Total
1.	Kanawha	273,205,720	8,005,551	--	281,211,271
2.	Berkeley	163,318,741	2,111,899	4,176,090	169,606,730
3.	Cabell	121,935,294	29,143,955	5,589,463	156,668,711
4.	Wood	130,455,772	8,513,212	3,141,050	142,110,034
5.	Raleigh	118,706,206	6,192,594	2,860,316	127,759,116
6.	Monongalia	103,813,197	11,408,862	3,415,800	118,637,860
7.	Harrison	111,665,578	2,565,288	--	114,230,866
8.	Jefferson	85,333,405	8,819,084	3,377,689	97,530,177
9.	Mercer	95,507,601	--	--	95,507,601
10.	Putnam	89,659,257	2,673,078	--	92,332,335
11.	Marion	81,761,770	199,217	--	81,960,987
12.	Marshall	54,847,556	20,532,015	2,684,588	78,064,159
13.	Fayette	69,008,075	5,005,055	--	74,013,129
14.	Wayne	71,454,093	739,293	--	72,193,386
15.	Logan	61,224,403	316,337	--	61,540,740
16.	Ohio	56,452,277	1,564,958	1,211,194	59,228,429
17.	Greenbrier	53,433,714	2,133,825	5,150	55,572,689
18.	Mingo	48,619,421	4,764,662	--	53,384,084
19.	Boone	50,778,765	--	--	50,778,765
20.	Mason	45,679,490	2,077,917	1,916,109	49,673,516
21.	Jackson	48,262,608	769,034	--	49,031,642
22.	Mineral	45,983,683	722,746	--	46,706,429
23.	Wyoming	43,685,195	252,259	707,191	44,644,646
24.	Randolph	41,143,981	3,376,738	--	44,520,719
25.	Preston	44,291,699	--	--	44,291,699
26.	Hancock	42,101,454	212,528	--	42,313,982
27.	McDowell	40,820,595	128,064	--	40,948,659
28.	Nicholas	40,925,140	--	--	40,925,140
29.	Lincoln	37,780,773	660,958	--	38,441,732
30.	Upshur	36,393,988	460,037	--	36,854,025
31.	Brooke	34,845,188	107,809	1,421,775	36,374,773
32.	Hampshire	32,022,467	130,631	480,336	32,633,434
33.	Wetzel	31,450,798	480,837	--	31,931,635
34.	Lewis	28,369,520	3,374,076	--	31,743,596
35.	Morgan	26,071,322	197,882	--	26,269,204
36.	Barbour	22,996,787	1,538,955	1,000,250	25,535,993
37.	Braxton	22,486,015	2,346,395	--	24,832,410
38.	Taylor	23,217,804	93,883	931,966	24,243,652
39.	Roane	22,792,627	--	297,684	23,090,311
40.	Hardy	19,521,321	2,666,806	--	22,188,126
41.	Clay	19,896,863	255,705	--	20,152,568
42.	Monroe	19,837,045	63,411	199,540	20,099,996
43.	Webster	14,824,576	4,535,694	--	19,360,269
44.	Summers	15,371,638	3,327,684	--	18,699,322
45.	Ritchie	18,164,906	39,376	--	18,204,283
46.	Grant	16,990,409	137,120	68,148	17,195,678
47.	Tyler	16,772,561	--	--	16,772,561
48.	Pleasants	15,908,598	--	--	15,908,598
49.	Doddridge	13,687,114	283,454	767,756	14,738,324
50.	Pendleton	11,575,350	1,866,304	--	13,441,654
51.	Pocahontas	12,731,383	--	--	12,731,383
52.	Tucker	11,604,191	74,050	--	11,678,241
53.	Calhoun	10,670,396	642,710	343,391	11,656,496
54.	Gilmer	10,835,823	--	--	10,835,823
55.	Wirt	9,595,737	25,692	--	9,621,429
-	State	2,790,489,892	145,537,640	34,595,484	2,970,623,017

Note: Excludes expenditures of Regional Education Service Agencies (RESAs) and Multi-County Vocational Centers (MCVCs).

OSF3

02/18/10

Current Exp by Function 09

**Special Funding
for the
Education of Students
with Exceptionalities
in West Virginia
for School Year 2009-2010**

The following pages list the special funds that are available through the West Virginia Department of Education, Office of Special Programs for the expansion, improvement and maintenance of special education and related services for students with exceptionalities in West Virginia. Both state and federal dollars are shown.

It should be noted that these figures do not include funds that are received and administered by other agencies and organizations. County school districts, colleges and universities may also receive direct federal grants for special projects.

Aid for Exceptional Students
State Account 1314-159
FY – 10

DATA NOTES

- (1) Base is equal to 1/3 of \$5,016,340 (aid to counties) divided equally among the 55 counties
- (2) 2008-2009 unduplicated count of exceptional students from Second Month Report.
- (3) Per Student Base
- (4) Remaining 2/3 allocated per exceptional student (\$66.2223 per student).
- (5) Subtotal of the aid to counties portion of the allocation [(1) + (4)].
- (6) Preschool base of \$10,000 per county school district.
- (7) December 1, 2008 child count of 3-5 year old preschool children with disabilities.
- (8) Per Student Base (Preschool)
- (9) Remaining \$470,482 allocated per preschool child with disabilities (\$80.0684 per child).
- (10) Preschool subtotal [(6) + (9)].
- (11) Total entitlement of \$6,036,822 [(5) + (10)].

STATE FUNDING FOR THE EDUCATION OF STUDENTS WITH EXCEPTIONALITIES
IN
WEST VIRGINIA FOR SCHOOL YEAR 2009-2010

SOURCE	PURPOSE	DISTRIBUTION	AMOUNT
0314-159 Aid for Exceptional Students			
County Grant Awards	To provide funding which may be expended by county boards of education for the initiation, maintenance and/or improvement of special education programs for school-age and preschool students with exceptionalities.	See Attachment	\$ 6,036,822.00
RESA Special Education Support	To assist county school districts in the planning, implementation and provision of special education and related services to exceptional students and to provide leadership to targeted schools in improving results for students with disabilities.	\$47,000 per RESA	\$ 376,000.00
Out-of-County Reimbursement	To provide partial reimbursement to counties for the provision of special education and related services to students placed in facilities operated or supported by the Department of Health and Human Resources and the Department of Corrections.	End-of-year reimbursement; based on number of students placed and available funding.	\$ 558,935.00
Out-of-State Instruction	To provide partial funding for students and youth with severe disabilities who are served in out-of-state placements.	Bi-annual reimbursement program; based on cost of placement, number of districts applying and available dollars.	\$ 300,000.00
		Sub-total	\$ 7,271,757.00

STATE FUNDING FOR THE EDUCATION OF STUDENTS WITH EXCEPTIONALITIES (continued)
 IN
 WEST VIRGINIA FOR SCHOOL YEAR 2009-2010

SOURCE	PURPOSE	DISTRIBUTION	AMOUNT
0314-160 Aid for Exceptional Students			
State Department Administration	Department of Education personnel salaries and None expenses.		\$ 490,000.00
	Office of Institutional Education Programs		\$ 3,204,082.00
Special State Projects	To assist in the support of Medicaid and gifted administration costs.		\$ 22,500.00
0314-634 High Acuity Special Needs	To support children with high acuity needs		\$ 250,000.00
0313-099 State Dept Unclassified	Gifted education and dispute resolution options.		\$ 50,000.00
0320 Schools for the Deaf and the Blind	To operate the West Virginia Schools for the Deaf and the Blind.	State Appropriation	\$ 12,651,153.00
		Sub-total	\$ 16,667,735.00
		TOTAL	\$ 23,939,492.00

**FEDERAL FUNDING FOR THE EDUCATION OF STUDENTS WITH DISABILITIES
IN
WEST VIRGINIA FOR SCHOOL YEAR 2008-2009**

SOURCE	PURPOSE	DISTRIBUTION	AMOUNT
Individuals with Disabilities Education Act (IDEA 2004)			
IDEA, Part B (FY 10)	To expand, improve and maintain direct services to children and youth with disabilities and support state-level administration.	88% flow through to counties, WVSDB* and OIEP** based on base year child counts and population and poverty levels, 1% for a high needs fund for distribution to counties, 9% for projects and 2% of grant for administration (See attachment for flow through amounts).	\$66,240,362.00
			\$ 761,148.00
			\$ 6,850,331.00
			\$ 1,635,066.00
IDEA ARRA, Part B (FY 10)	Same as above.	100% Flow through to Counties	\$75,951,991.00
		Sub-total	\$151,438,898.00
IDEA, Section 619 Preschool Grant (FY 10)	To assist in the provision of services to preschool children with disabilities.	74% flow through to counties and WVSDB based on base year child counts and population and poverty levels, 21% for discretionary projects and 5% of grant for administration (See attachment for flow through amounts).	\$ 2,529,045.00
			\$ 719,706.00
			\$ 179,927.00
IDEA ARRA, Section 619 Preschool (FY 10)	Same as above.	100% flow through to counties.	\$3,614,631.00
		Sub-total	\$ 7,043,309.00
		TOTAL	\$158,482,207.00

* WV Schools for the Deaf and the Blind (WVSDB)

** Office of Institutional Education Programs (OIEP), West Virginia Department of Education, provides services to state operated programs and facilities under the West Virginia Department of Corrections.

COUNTY BOARDS OF EDUCATION, WVSD&B, & OIEP
SPECIAL EDUCATION
8715-096 IDEA PART B (611 & 619) and State Aid (0314-159) Funding
FOR THE 2009-10 YEAR (IDEA includes ARRA funding)

COUNTY	STATE SPECIAL EDUCATION ALLOCATION 0314-159	IDEA PRESCHOOL 8715-096 Total Entitlement (Includes Regular IDEA 2010 and ARRA)*	IDEA SCHOOL AGE 8715-096 Total Entitlement (Includes Regular IDEA 2010 and ARRA)**
BARBOUR	\$ 72,481.00	\$ 56,757.00	\$ 1,296,759.00
BERKELEY	\$ 269,124.00	\$ 268,093.00	\$ 7,948,454.00
BOONE	\$ 107,594.00	\$ 102,775.00	\$ 2,360,670.00
BRAXTON	\$ 76,042.00	\$ 80,980.00	\$ 1,257,553.00
BROOKE	\$ 96,990.00	\$ 66,023.00	\$ 1,733,842.00
CABELL	\$ 194,879.00	\$ 267,122.00	\$ 6,576,732.00
CALHOUN	\$ 53,913.00	\$ 46,704.00	\$ 624,876.00
CLAY	\$ 67,413.00	\$ 37,559.00	\$ 1,065,471.00
DODDRIDGE	\$ 59,183.00	\$ 19,517.00	\$ 633,640.00
FAYETTE	\$ 120,662.00	\$ 186,743.00	\$ 3,508,551.00
GILMER	\$ 51,056.00	\$ 29,113.00	\$ 523,059.00
GRANT	\$ 70,715.00	\$ 40,750.00	\$ 997,470.00
GREENBRIER	\$ 116,426.00	\$ 132,171.00	\$ 2,715,972.00
HAMPSHIRE	\$ 90,118.00	\$ 80,774.00	\$ 1,867,990.00
HANCOCK	\$ 105,683.00	\$ 75,207.00	\$ 2,223,992.00
HARDY	\$ 68,267.00	\$ 49,880.00	\$ 1,183,489.00
HARRISON	\$ 203,098.00	\$ 248,301.00	\$ 5,653,038.00
JACKSON	\$ 111,333.00	\$ 151,407.00	\$ 2,473,998.00
JEFFERSON	\$ 137,000.00	\$ 133,093.00	\$ 3,849,015.00
KANAWHA	\$ 419,147.00	\$ 592,999.00	\$ 14,410,505.00
LEWIS	\$ 81,487.00	\$ 72,449.00	\$ 1,375,669.00
LINCOLN	\$ 96,980.00	\$ 102,470.00	\$ 2,009,652.00
LOGAN	\$ 109,614.00	\$ 137,915.00	\$ 3,228,441.00
MARION	\$ 142,118.00	\$ 157,613.00	\$ 3,961,360.00
MARSHALL	\$ 116,319.00	\$ 124,404.00	\$ 2,644,474.00
MASON	\$ 114,402.00	\$ 119,250.00	\$ 2,269,907.00
MCDOWELL	\$ 88,474.00	\$ 72,161.00	\$ 2,216,756.00
MERCER	\$ 150,296.00	\$ 220,092.00	\$ 4,866,006.00
MINERAL	\$ 104,022.00	\$ 102,924.00	\$ 2,266,662.00
MINGO	\$ 99,722.00	\$ 95,469.00	\$ 2,537,936.00
MONONGALIA	\$ 181,109.00	\$ 192,168.00	\$ 5,035,857.00
MONROE	\$ 66,134.00	\$ 56,364.00	\$ 1,009,082.00
MORGAN	\$ 70,497.00	\$ 45,138.00	\$ 1,257,109.00
NICHOLAS	\$ 98,019.00	\$ 88,772.00	\$ 2,122,593.00
OHIO	\$ 120,011.00	\$ 141,160.00	\$ 3,199,273.00
PENDLETON	\$ 58,057.00	\$ 32,342.00	\$ 574,783.00
PLEASANTS	\$ 61,300.00	\$ 40,000.00	\$ 689,323.00
POCAHONTAS	\$ 58,907.00	\$ 37,441.00	\$ 651,109.00
PRESTON	\$ 111,544.00	\$ 82,410.00	\$ 2,349,249.00
PUTNAM	\$ 165,751.00	\$ 149,092.00	\$ 4,507,509.00
RALEIGH	\$ 186,611.00	\$ 276,900.00	\$ 6,199,584.00
RANDOLPH	\$ 103,025.00	\$ 82,190.00	\$ 2,279,482.00
RITCHIE	\$ 65,356.00	\$ 46,994.00	\$ 848,360.00
ROANE	\$ 75,362.00	\$ 80,029.00	\$ 1,365,059.00
SUMMERS	\$ 58,551.00	\$ 30,368.00	\$ 817,237.00
TAYLOR	\$ 70,528.00	\$ 65,984.00	\$ 1,233,727.00
TUCKER	\$ 54,735.00	\$ 31,883.00	\$ 564,836.00
TYLER	\$ 62,811.00	\$ 37,983.00	\$ 772,193.00
UPSHUR	\$ 95,820.00	\$ 73,061.00	\$ 1,960,073.00
WAYNE	\$ 156,508.00	\$ 175,184.00	\$ 3,946,284.00
WEBSTER	\$ 58,771.00	\$ 39,104.00	\$ 851,008.00
WETZEL	\$ 86,761.00	\$ 69,795.00	\$ 1,549,383.00
WIRT	\$ 51,371.00	\$ 30,470.00	\$ 507,500.00
WOOD	\$ 217,468.00	\$ 274,188.00	\$ 6,591,046.00
WYOMING	\$ 107,257.00	\$ 100,662.00	\$ 2,179,967.00
WV Sch D & B	\$ -	\$ 46,947.00	\$ 143,693.00
OFC OF INST ED	\$ -	\$ -	\$ 467,244.00
TOTALS	\$ 6,036,822.00	\$ 6,197,344.00	\$ 143,954,502.00

*Includes \$53,668 in IDEA Preschool Discretionary Funding to Correct Omission of Non-Public Count in Initial Calculations

**Includes \$1,762,149 in IDEA Schoolage Discretionary Funding to Correct Omission of Non-Public Count in Initial Calculations

STUDENT ENROLLMENT

**COUNTY BOARDS OF EDUCATION
HEADCOUNT (STUDENT) ENROLLMENT BY GRADE - 2ND MONTH
2009-10 SCHOOL YEAR**

County	Early Childhood		Kinder- garten	First	Second	Third	Fourth	Fifth
	Community Based	School Based						
Barbour	44	102	170	163	181	158	162	180
Berkeley	165	541	1,371	1,298	1,387	1,331	1,303	1,273
Boone	151	126	384	348	325	353	327	336
Braxton	-	139	156	167	179	139	159	161
Brooke	64	48	246	240	222	233	270	263
Cabell	418	242	1,035	948	943	958	917	903
Calhoun	30	35	65	82	83	84	76	80
Clay	139	-	149	156	132	133	132	155
Doddridge	20	38	80	70	81	81	90	87
Fayette	103	52	516	517	498	519	511	484
Gilmer	-	65	68	50	61	66	62	65
Grant	1	87	135	149	126	132	155	150
Greenbrier	38	250	395	367	390	386	396	381
Hampshire	61	102	245	268	227	257	302	255
Hancock	81	115	342	323	336	309	310	309
Hardy	20	99	183	177	165	181	146	164
Harrison	319	332	833	781	746	786	819	773
Jackson	110	178	352	350	375	375	358	363
Jefferson	193	63	692	688	734	682	686	635
Kanawha	441	820	2,212	2,227	2,206	2,071	2,118	2,105
Lewis	149	-	156	207	178	195	183	175
Lincoln	214	5	310	304	269	245	296	260
Logan	213	98	497	449	482	471	448	464
Marion	239	158	623	594	585	576	603	585
Marshall	115	135	334	320	346	350	350	327
Mason	27	233	353	274	312	316	312	307
McDowell	196	15	295	271	286	252	275	279
Mercer	211	295	696	735	734	690	737	657
Mineral	39	236	339	298	321	309	338	334
Mingo	252	-	362	362	378	347	373	326
Monongalia	178	349	820	760	734	783	721	753
Monroe	-	106	138	129	144	142	140	154
Morgan	104	29	161	183	190	176	206	178
Nicholas	130	37	306	305	291	284	292	283
Ohio	172	125	393	375	361	356	351	366
Pendleton	30	41	71	93	74	66	74	80
Pleasants	28	33	82	78	80	92	101	89
Pocahontas	18	47	89	82	87	84	88	93
Preston	86	152	379	344	329	308	341	326
Putnam	239	121	757	694	703	710	714	719
Raleigh	166	501	901	931	1,003	908	953	856
Randolph	224	5	346	325	301	340	321	265
Ritchie	28	98	122	127	124	120	94	96
Roane	125	2	205	181	189	169	209	200
Summers	10	98	115	114	109	105	107	98
Taylor	55	69	212	197	171	168	172	194
Tucker	-	63	75	86	70	63	83	73
Tyler	-	85	104	74	116	92	113	113
Upshur	141	31	296	269	292	298	263	271
Wayne	225	102	567	548	565	543	579	580
Webster	72	30	110	104	111	118	103	85
Wetzel	-	138	232	192	212	177	196	210
Wirt	49	-	62	57	64	44	71	72
Wood	284	401	981	966	974	958	979	1,023
Wyoming	19	168	328	333	295	296	297	323
Total	6,436	7,440	21,446	20,730	20,877	20,385	20,782	20,336

OSF

12/04/09

Headcount Enroll 2nd Mo 10

**COUNTY BOARDS OF EDUCATION
HEADCOUNT (STUDENT) ENROLLMENT BY GRADE - 2ND MONTH
2009-10 SCHOOL YEAR**

County	Sixth	Seventh	Eight	Ninth	Tenth	Eleventh	Twelfth	Total
Barbour	170	175	187	205	187	197	197	2,478
Berkeley	1,299	1,331	1,211	1,567	1,220	1,117	1,032	17,446
Boone	348	363	338	375	347	271	280	4,672
Braxton	163	134	147	200	165	175	146	2,230
Brooke	248	235	257	319	231	266	262	3,404
Cabell	943	894	860	996	873	830	792	12,552
Calhoun	74	91	90	77	72	74	91	1,104
Clay	152	134	138	157	170	146	150	2,043
Doddridge	71	79	87	111	99	84	91	1,169
Fayette	511	531	538	544	489	495	451	6,759
Gilmer	73	73	80	77	69	68	62	939
Grant	151	158	153	140	142	124	132	1,935
Greenbrier	386	372	386	434	384	372	348	5,285
Hampshire	249	292	279	331	293	256	236	3,653
Hancock	312	276	361	381	318	260	278	4,311
Hardy	168	177	173	196	152	148	158	2,307
Harrison	830	780	782	1,077	877	801	660	11,196
Jackson	380	363	361	415	410	328	322	5,040
Jefferson	622	573	654	632	607	596	538	8,595
Kanawha	2,175	2,103	2,089	2,470	1,940	1,734	1,770	28,481
Lewis	190	193	177	231	228	202	186	2,650
Lincoln	282	287	261	271	237	185	200	3,626
Logan	440	476	490	529	494	457	423	6,431
Marion	582	576	552	640	610	607	586	8,116
Marshall	353	343	335	375	390	374	374	4,821
Mason	314	319	335	326	341	277	262	4,308
McDowell	247	269	270	282	270	233	234	3,674
Mercer	726	730	693	869	634	601	544	9,552
Mineral	304	321	302	336	316	323	344	4,460
Mingo	300	319	314	347	333	303	270	4,586
Monongalia	730	747	733	935	793	735	688	10,459
Monroe	144	128	137	144	165	148	126	1,945
Morgan	208	205	217	243	190	203	162	2,655
Nicholas	290	306	289	298	326	313	292	4,042
Ohio	383	375	398	424	415	392	399	5,285
Pendleton	86	66	96	73	80	70	85	1,085
Pleasants	97	86	111	116	102	101	103	1,299
Pocahontas	79	92	89	96	90	86	82	1,202
Preston	329	344	345	399	337	312	297	4,628
Putnam	718	657	710	848	663	631	633	9,517
Raleigh	941	877	836	909	880	831	847	12,340
Randolph	306	307	298	379	317	300	322	4,356
Ritchie	117	103	111	143	109	103	131	1,626
Roane	201	192	190	189	172	161	169	2,554
Summers	108	115	111	120	124	105	109	1,548
Taylor	169	186	162	194	166	165	170	2,450
Tucker	81	69	82	79	93	80	99	1,096
Tyler	116	104	107	124	107	112	115	1,482
Upshur	276	260	289	359	285	269	226	3,825
Wayne	577	538	549	652	547	472	512	7,556
Webster	104	116	116	135	123	116	134	1,577
Wetzel	223	208	186	236	219	214	221	2,864
Wirt	76	67	83	81	80	84	77	967
Wood	1,011	1,028	947	1,108	972	937	917	13,486
Wyoming	340	312	344	321	252	272	261	4,161
Total	20,773	20,455	20,436	23,515	20,505	19,116	18,596	281,828

OSF
12/04/09
Headcount Enro

**COMPARISON OF ENROLLMENT FACTORS
AS OF SECOND SCHOOL MONTH
2008-09 AND 2009-10**

County	Early Childhood Headcount			Early Childhood FTE		
	2008-09	2009-10	Increase/ Decrease	2008-09	2009-10	Increase/ Decrease
Barbour	142	146	4	141.50	145.00	3.50
Berkeley	607	706	99	440.90	497.70	56.80
Boone	248	277	29	246.00	269.50	23.50
Braxton	138	139	1	135.12	136.12	1.00
Brooke	105	112	7	78.20	99.21	21.01
Cabell	656	660	4	632.50	626.80	(5.70)
Calhoun	61	65	4	54.80	58.00	3.20
Clay	148	139	(9)	148.00	139.00	(9.00)
Doddridge	54	58	4	34.40	38.70	4.30
Fayette	152	155	3	119.40	123.20	3.80
Gilmer	59	65	6	59.00	63.80	4.80
Grant	85	88	3	85.00	87.95	2.95
Greenbrier	244	288	44	179.60	285.40	105.80
Hampshire	150	163	13	92.50	106.00	13.50
Hancock	171	196	25	142.00	167.90	25.90
Hardy	108	119	11	69.70	112.70	43.00
Harrison	611	651	40	593.00	640.80	47.80
Jackson	280	288	8	270.40	285.60	15.20
Jefferson	220	256	36	184.60	135.50	(49.10)
Kanawha	1,186	1,261	75	767.17	752.40	(14.77)
Lewis	125	149	24	125.00	131.60	6.60
Lincoln	222	219	(3)	218.20	215.40	(2.80)
Logan	327	311	(16)	320.20	306.20	(14.00)
Marion	396	397	1	356.60	356.60	-
Marshall	231	250	19	200.00	241.40	41.40
Mason	290	260	(30)	232.00	213.00	(19.00)
McDowell	187	211	24	187.00	207.16	20.16
Mercer	507	506	(1)	447.23	455.35	8.12
Mineral	282	275	(7)	265.83	263.48	(2.34)
Mingo	255	252	(3)	247.50	252.00	4.50
Monongalia	498	527	29	489.72	520.56	30.84
Monroe	96	106	10	72.35	75.75	3.40
Morgan	114	133	19	114.00	83.90	(30.10)
Nicholas	170	167	(3)	166.88	167.00	0.12
Ohio	249	297	48	193.30	232.60	39.30
Pendleton	76	71	(5)	75.20	71.00	(4.20)
Pleasants	80	61	(19)	80.00	61.00	(19.00)
Pocahontas	78	65	(13)	57.20	63.00	5.80
Preston	223	238	15	211.80	224.80	13.00
Putnam	324	360	36	241.50	288.50	47.00
Raleigh	603	667	64	449.30	533.50	84.20
Randolph	224	229	5	223.60	229.00	5.40
Ritchie	100	126	26	96.50	120.00	23.50
Roane	142	127	(15)	137.80	125.80	(12.00)
Summers	85	108	23	83.50	107.50	24.00
Taylor	130	124	(6)	114.20	112.00	(2.20)
Tucker	65	63	(2)	65.00	63.00	(2.00)
Tyler	95	85	(10)	86.10	74.40	(11.70)
Upshur	157	172	15	153.40	172.00	18.60
Wayne	337	327	(10)	302.80	313.30	10.50
Webster	79	102	23	62.00	91.70	29.70
Wetzel	157	138	(19)	143.00	125.00	(18.00)
Wirt	41	49	8	38.00	49.00	11.00
Wood	570	685	115	513.80	646.00	132.20
Wyoming	195	187	(8)	187.20	181.30	(5.90)
Total	13,135	13,876	741	11,431.49	12,145.08	713.60

OSF

12/15/09

Enrollment Factor Comparisons 10

**COMPARISON OF ENROLLMENT FACTORS
AS OF SECOND SCHOOL MONTH
2008-09 AND 2009-10**

County	Kindergarten (5 Year Olds) Headcount			Kindergarten (5 Year Olds) FTE		
	2008-09	2009-10	Increase/ Decrease	2008-09	2009-10	Increase/ Decrease
Barbour	164	170	6	164.00	170.00	6.00
Berkeley	1,345	1,371	26	1,345.00	1,371.00	26.00
Boone	369	384	15	369.00	384.00	15.00
Braxton	170	156	(14)	170.00	156.00	(14.00)
Brooke	237	246	9	237.00	246.00	9.00
Cabell	982	1,035	53	982.00	1,035.00	53.00
Calhoun	87	65	(22)	87.00	65.00	(22.00)
Clay	150	149	(1)	150.00	149.00	(1.00)
Doddridge	70	80	10	70.00	80.00	10.00
Fayette	526	516	(10)	526.00	516.00	(10.00)
Gilmer	55	68	13	55.00	68.00	13.00
Grant	148	135	(13)	148.00	135.00	(13.00)
Greenbrier	372	395	23	372.00	395.00	23.00
Hampshire	280	245	(35)	280.00	245.00	(35.00)
Hancock	332	342	10	332.00	342.00	10.00
Hardy	180	183	3	180.00	183.00	3.00
Harrison	806	833	27	806.00	833.00	27.00
Jackson	348	352	4	348.00	352.00	4.00
Jefferson	600	692	92	600.00	692.00	92.00
Kanawha	2,189	2,212	23	2,189.00	2,211.20	22.20
Lewis	191	156	(35)	191.00	156.00	(35.00)
Lincoln	318	310	(8)	318.00	310.00	(8.00)
Logan	452	497	45	452.00	497.00	45.00
Marion	588	623	35	588.00	623.00	35.00
Marshall	321	334	13	321.00	334.00	13.00
Mason	273	353	80	273.00	353.00	80.00
McDowell	271	295	24	271.00	295.00	24.00
Mercer	751	696	(55)	751.00	696.00	(55.00)
Mineral	307	339	32	307.00	339.00	32.00
Mingo	386	362	(24)	386.00	362.00	(24.00)
Monongalia	739	820	81	739.00	820.00	81.00
Monroe	125	138	13	125.00	138.00	13.00
Morgan	187	161	(26)	187.00	161.00	(26.00)
Nicholas	316	306	(10)	316.00	306.00	(10.00)
Ohio	376	393	17	376.00	393.00	17.00
Pendleton	97	71	(26)	97.00	71.00	(26.00)
Pleasants	78	82	4	78.00	82.00	4.00
Pocahontas	82	89	7	82.00	89.00	7.00
Preston	341	379	38	341.00	379.00	38.00
Putnam	696	757	61	696.00	757.00	61.00
Raleigh	903	901	(2)	903.00	901.00	(2.00)
Randolph	334	346	12	334.00	346.00	12.00
Ritchie	131	122	(9)	131.00	122.00	(9.00)
Roane	174	205	31	174.00	205.00	31.00
Summers	115	115	-	115.00	115.00	-
Taylor	224	212	(12)	224.00	212.00	(12.00)
Tucker	86	75	(11)	86.00	75.00	(11.00)
Tyler	73	104	31	73.00	104.00	31.00
Upshur	287	296	9	287.00	296.00	9.00
Wayne	582	567	(15)	582.00	567.00	(15.00)
Webster	106	110	4	106.00	110.00	4.00
Wetzel	208	232	24	208.00	232.00	24.00
Wirt	54	62	8	54.00	62.00	8.00
Wood	966	981	15	966.00	981.00	15.00
Wyoming	357	328	(29)	357.00	328.00	(29.00)
Total	20,905	21,446	541	20,905.00	21,445.20	540.20

OSF
12/15/09
Enrollment Factor C

**COMPARISON OF ENROLLMENT FACTORS
AS OF SECOND SCHOOL MONTH
2008-09 AND 2009-10**

County	Grades 1 - 8 Headcount			Grades 1 - 8 FTE		
	2008-09	2009-10	Increase/ Decrease	2008-09	2009-10	Increase/ Decrease
Barbour	1,410	1,376	(34)	1,409.14	1,374.27	(34.86)
Berkeley	10,379	10,433	54	10,373.18	10,431.10	57.92
Boone	2,726	2,738	12	2,726.00	2,738.00	12.00
Braxton	1,275	1,249	(26)	1,275.00	1,249.00	(26.00)
Brooke	1,997	1,968	(29)	1,997.00	1,968.00	(29.00)
Cabell	7,341	7,366	25	7,341.00	7,364.29	23.29
Calhoun	659	660	1	659.00	660.00	1.00
Clay	1,097	1,132	35	1,097.00	1,132.00	35.00
Doddridge	691	646	(45)	691.00	646.00	(45.00)
Fayette	4,087	4,109	22	4,087.00	4,109.00	22.00
Gilmer	543	530	(13)	543.00	530.00	(13.00)
Grant	1,178	1,174	(4)	1,178.00	1,174.00	(4.00)
Greenbrier	3,095	3,064	(31)	3,095.00	3,064.00	(31.00)
Hampshire	2,192	2,129	(63)	2,192.00	2,129.00	(63.00)
Hancock	2,531	2,536	5	2,531.00	2,536.00	5.00
Hardy	1,382	1,351	(31)	1,382.00	1,350.10	(31.90)
Harrison	6,376	6,297	(79)	6,376.00	6,296.14	(79.86)
Jackson	2,933	2,925	(8)	2,933.00	2,921.93	(11.07)
Jefferson	5,161	5,274	113	5,159.38	5,270.14	110.76
Kanawha	17,079	17,094	15	17,079.00	17,093.20	14.20
Lewis	1,516	1,498	(18)	1,516.00	1,498.00	(18.00)
Lincoln	2,188	2,204	16	2,188.00	2,204.00	16.00
Logan	3,761	3,720	(41)	3,761.00	3,720.00	(41.00)
Marion	4,604	4,653	49	4,604.00	4,653.00	49.00
Marshall	2,762	2,724	(38)	2,759.34	2,721.27	(38.07)
Mason	2,528	2,489	(39)	2,528.00	2,489.00	(39.00)
McDowell	2,169	2,149	(20)	2,169.00	2,149.00	(20.00)
Mercer	5,731	5,702	(29)	5,731.00	5,702.00	(29.00)
Mineral	2,551	2,527	(24)	2,550.07	2,525.57	(24.50)
Mingo	2,742	2,719	(23)	2,742.00	2,719.00	(23.00)
Monongalia	5,874	5,961	87	5,873.13	5,959.58	86.45
Monroe	1,129	1,118	(11)	1,129.00	1,118.00	(11.00)
Morgan	1,597	1,563	(34)	1,597.00	1,563.00	(34.00)
Nicholas	2,331	2,340	9	2,331.00	2,340.00	9.00
Ohio	2,966	2,965	(1)	2,966.00	2,965.00	(1.00)
Pendleton	613	635	22	613.00	634.50	21.50
Pleasants	767	734	(33)	767.00	734.00	(33.00)
Pocahontas	702	694	(8)	702.00	692.13	(9.88)
Preston	2,677	2,666	(11)	2,677.00	2,666.00	(11.00)
Putnam	5,633	5,625	(8)	5,633.00	5,625.00	(8.00)
Raleigh	7,315	7,305	(10)	7,315.00	7,304.80	(10.20)
Randolph	2,512	2,463	(49)	2,512.00	2,462.25	(49.75)
Ritchie	886	892	6	886.00	892.00	6.00
Roane	1,499	1,531	32	1,499.00	1,531.00	32.00
Summers	852	867	15	852.00	867.00	15.00
Taylor	1,387	1,419	32	1,387.00	1,419.00	32.00
Tucker	602	607	5	602.00	607.00	5.00
Tyler	869	835	(34)	869.00	835.00	(34.00)
Upshur	2,267	2,218	(49)	2,267.00	2,218.00	(49.00)
Wayne	4,517	4,479	(38)	4,517.00	4,479.00	(38.00)
Webster	873	857	(16)	873.00	857.00	(16.00)
Wetzel	1,622	1,604	(18)	1,622.00	1,603.13	(18.88)
Wirt	536	534	(2)	536.00	534.00	(2.00)
Wood	8,006	7,886	(120)	8,006.00	7,882.12	(123.88)
Wyoming	2,495	2,540	45	2,495.00	2,540.00	45.00
Total	165,211	164,774	(437)	165,198.23	164,745.51	(452.72)

OSF
12/15/09
Enrollment Factor C

**COMPARISON OF ENROLLMENT FACTORS
AS OF SECOND SCHOOL MONTH
2008-09 AND 2009-10**

County	Grades 9 - 12 Headcount			Grades 9 -12 FTE		
	2008-09	2009-10	Increase/ Decrease	2008-09	2009-10	Increase/ Decrease
Barbour	780	786	6	779.00	786.00	7.00
Berkeley	4,883	4,936	53	4,877.51	4,931.30	53.79
Boone	1,279	1,273	(6)	1,279.00	1,273.00	(6.00)
Braxton	706	686	(20)	706.00	686.00	(20.00)
Brooke	1,084	1,078	(6)	1,084.00	1,078.00	(6.00)
Cabell	3,543	3,491	(52)	3,537.60	3,489.31	(48.29)
Calhoun	319	314	(5)	319.00	314.00	(5.00)
Clay	631	623	(8)	631.00	623.00	(8.00)
Doddridge	391	385	(6)	391.00	385.00	(6.00)
Fayette	2,045	1,979	(66)	2,045.00	1,979.00	(66.00)
Gilmer	284	276	(8)	284.00	276.00	(8.00)
Grant	564	538	(26)	564.00	538.00	(26.00)
Greenbrier	1,537	1,538	1	1,537.00	1,538.00	1.00
Hampshire	1,105	1,116	11	1,105.00	1,116.00	11.00
Hancock	1,293	1,237	(56)	1,291.50	1,237.00	(54.50)
Hardy	683	654	(29)	683.00	654.00	(29.00)
Harrison	3,399	3,415	16	3,398.50	3,415.00	16.50
Jackson	1,506	1,475	(31)	1,506.00	1,475.00	(31.00)
Jefferson	2,417	2,373	(44)	2,415.71	2,372.43	(43.28)
Kanawha	8,011	7,914	(97)	8,011.00	7,914.00	(97.00)
Lewis	854	847	(7)	854.00	847.00	(7.00)
Lincoln	878	893	15	878.00	893.00	15.00
Logan	1,966	1,903	(63)	1,966.00	1,903.00	(63.00)
Marion	2,534	2,443	(91)	2,534.00	2,443.00	(91.00)
Marshall	1,572	1,513	(59)	1,572.00	1,513.00	(59.00)
Mason	1,208	1,206	(2)	1,207.50	1,206.00	(1.50)
McDowell	1,048	1,019	(29)	1,048.00	1,019.00	(29.00)
Mercer	2,549	2,648	99	2,549.00	2,648.00	99.00
Mineral	1,411	1,319	(92)	1,409.25	1,319.00	(90.25)
Mingo	1,305	1,253	(52)	1,305.00	1,253.00	(52.00)
Monongalia	3,183	3,151	(32)	3,179.38	3,149.71	(29.66)
Monroe	605	583	(22)	605.00	583.00	(22.00)
Morgan	794	798	4	794.00	798.00	4.00
Nicholas	1,266	1,229	(37)	1,265.50	1,229.00	(36.50)
Ohio	1,688	1,630	(58)	1,688.00	1,627.63	(60.38)
Pendleton	315	308	(7)	314.00	308.00	(6.00)
Pleasants	421	422	1	421.00	422.00	1.00
Pocahontas	347	354	7	347.00	354.00	7.00
Preston	1,318	1,345	27	1,318.00	1,345.00	27.00
Putnam	2,688	2,775	87	2,686.75	2,771.25	84.50
Raleigh	3,495	3,467	(28)	3,495.00	3,467.00	(28.00)
Randolph	1,355	1,318	(37)	1,355.00	1,317.50	(37.50)
Ritchie	472	486	14	472.00	486.00	14.00
Roane	723	691	(32)	723.00	691.00	(32.00)
Summers	480	458	(22)	480.00	458.00	(22.00)
Taylor	685	695	10	684.25	695.00	10.75
Tucker	374	351	(23)	374.00	351.00	(23.00)
Tyler	442	458	16	442.00	458.00	16.00
Upshur	1,151	1,139	(12)	1,151.00	1,139.00	(12.00)
Wayne	2,290	2,183	(107)	2,290.00	2,183.00	(107.00)
Webster	492	508	16	492.00	508.00	16.00
Wetzel	933	890	(43)	933.00	890.00	(43.00)
Wirt	323	322	(1)	323.00	322.00	(1.00)
Wood	3,939	3,934	(5)	3,939.00	3,932.29	(6.71)
Wyoming	1,093	1,106	13	1,093.00	1,106.00	13.00
Total	82,657	81,732	(925)	82,632.45	81,715.42	(917.03)

OSF
12/15/09
Enrollment Factor C

**COMPARISON OF ENROLLMENT FACTORS
AS OF SECOND SCHOOL MONTH
2008-09 AND 2009-10**

County	Grades PK - 12 Headcount			Grades PK - 12 Net Enrollment (W/O Certified Adults)		
	2008-09	2009-10	Increase/ Decrease	2008-09	2009-10	Increase/ Decrease
Barbour	2,496	2,478	(18)	2,493.64	2,475.27	(18.36)
Berkeley	17,214	17,446	232	17,036.59	17,231.10	194.51
Boone	4,622	4,672	50	4,620.00	4,664.50	44.50
Braxton	2,289	2,230	(59)	2,286.12	2,227.12	(59.00)
Brooke	3,423	3,404	(19)	3,396.20	3,391.21	(4.99)
Cabell	12,522	12,552	30	12,493.10	12,515.40	22.30
Calhoun	1,126	1,104	(22)	1,119.80	1,097.00	(22.80)
Clay	2,026	2,043	17	2,026.00	2,043.00	17.00
Doddridge	1,206	1,169	(37)	1,186.40	1,149.70	(36.70)
Fayette	6,810	6,759	(51)	6,777.40	6,727.20	(50.20)
Gilmer	941	939	(2)	941.00	937.80	(3.20)
Grant	1,975	1,935	(40)	1,975.00	1,934.95	(40.05)
Greenbrier	5,248	5,285	37	5,183.60	5,282.40	98.80
Hampshire	3,727	3,653	(74)	3,669.50	3,596.00	(73.50)
Hancock	4,327	4,311	(16)	4,296.50	4,282.90	(13.60)
Hardy	2,353	2,307	(46)	2,314.70	2,299.80	(14.90)
Harrison	11,192	11,196	4	11,173.50	11,184.94	11.44
Jackson	5,067	5,040	(27)	5,057.40	5,034.53	(22.87)
Jefferson	8,398	8,595	197	8,359.69	8,470.07	110.38
Kanawha	28,465	28,481	16	28,046.17	27,970.80	(75.37)
Lewis	2,686	2,650	(36)	2,686.00	2,632.60	(53.40)
Lincoln	3,606	3,626	20	3,602.20	3,622.40	20.20
Logan	6,506	6,431	(75)	6,499.20	6,426.20	(73.00)
Marion	8,122	8,116	(6)	8,082.60	8,075.60	(7.00)
Marshall	4,886	4,821	(65)	4,852.34	4,809.67	(42.67)
Mason	4,299	4,308	9	4,240.50	4,261.00	20.50
McDowell	3,675	3,674	(1)	3,675.00	3,670.16	(4.84)
Mercer	9,538	9,552	14	9,478.23	9,501.35	23.13
Mineral	4,551	4,460	(91)	4,532.15	4,447.06	(85.09)
Mingo	4,688	4,586	(102)	4,680.50	4,586.00	(94.50)
Monongalia	10,294	10,459	165	10,281.22	10,449.85	168.63
Monroe	1,955	1,945	(10)	1,931.35	1,914.75	(16.60)
Morgan	2,692	2,655	(37)	2,692.00	2,605.90	(86.10)
Nicholas	4,083	4,042	(41)	4,079.38	4,042.00	(37.38)
Ohio	5,279	5,285	6	5,223.30	5,218.23	(5.07)
Pendleton	1,101	1,085	(16)	1,099.20	1,084.50	(14.70)
Pleasants	1,346	1,299	(47)	1,346.00	1,299.00	(47.00)
Pocahontas	1,209	1,202	(7)	1,188.20	1,198.13	9.92
Preston	4,559	4,628	69	4,547.80	4,614.80	67.00
Putnam	9,341	9,517	176	9,257.25	9,441.75	184.50
Raleigh	12,316	12,340	24	12,162.30	12,206.30	44.00
Randolph	4,425	4,356	(69)	4,424.60	4,354.75	(69.85)
Ritchie	1,589	1,626	37	1,585.50	1,620.00	34.50
Roane	2,538	2,554	16	2,533.80	2,552.80	19.00
Summers	1,532	1,548	16	1,530.50	1,547.50	17.00
Taylor	2,426	2,450	24	2,409.45	2,438.00	28.55
Tucker	1,127	1,096	(31)	1,127.00	1,096.00	(31.00)
Tyler	1,479	1,482	3	1,470.10	1,471.40	1.30
Upshur	3,862	3,825	(37)	3,858.40	3,825.00	(33.40)
Wayne	7,726	7,556	(170)	7,691.80	7,542.30	(149.50)
Webster	1,550	1,577	27	1,533.00	1,566.70	33.70
Wetzel	2,920	2,864	(56)	2,906.00	2,850.13	(55.88)
Wirt	954	967	13	951.00	967.00	16.00
Wood	13,481	13,486	5	13,424.80	13,441.41	16.61
Wyoming	4,140	4,161	21	4,132.20	4,155.30	23.10
Total	281,908	281,828	(80)	280,167.17	280,051.21	(115.95)

OSF
12/15/09
Enrollment Factor C

**COMPARISON OF ENROLLMENT FACTORS
AS OF SECOND SCHOOL MONTH
2008-09 AND 2009-10**

County	Special Education Reported (Unduplicated)			Advanced Placement, Dual Credit, & Int'l Baccalaureate		
	2008-09	2009-10	Increase/ Decrease	2008-09	2009-10	Increase/ Decrease
Barbour	430	439	9	56	64	8
Berkeley	2,992	3,011	19	452	511	59
Boone	901	907	6	176	150	(26)
Braxton	433	432	(1)	100	91	(9)
Brooke	759	771	12	96	131	35
Cabell	1,999	1,981	(18)	453	427	(26)
Calhoun	175	163	(12)	22	14	(8)
Clay	345	352	7	31	32	1
Doddridge	257	254	(3)	38	27	(11)
Fayette	1,027	953	(74)	197	233	36
Gilmer	150	154	4	29	25	(4)
Grant	413	407	(6)	43	68	25
Greenbrier	1,015	998	(17)	137	146	9
Hampshire	677	646	(31)	116	101	(15)
Hancock	854	869	15	156	131	(25)
Hardy	370	332	(38)	87	69	(18)
Harrison	2,163	2,254	91	316	356	40
Jackson	897	883	(14)	220	179	(41)
Jefferson	1,287	1,271	(16)	192	262	70
Kanawha	5,093	4,982	(111)	1,164	1,056	(108)
Lewis	566	551	(15)	67	61	(6)
Lincoln	754	746	(8)	53	34	(19)
Logan	894	809	(85)	253	267	14
Marion	1,351	1,305	(46)	397	372	(25)
Marshall	988	1,007	19	297	300	3
Mason	924	819	(105)	207	211	4
McDowell	657	663	6	81	71	(10)
Mercer	1,437	1,402	(35)	292	314	22
Mineral	841	846	5	178	167	(11)
Mingo	741	695	(46)	200	331	131
Monongalia	1,970	2,017	47	551	599	48
Monroe	339	331	(8)	106	26	(80)
Morgan	394	360	(34)	71	90	19
Nicholas	783	820	37	103	96	(7)
Ohio	1,022	1,036	14	230	218	(12)
Pendleton	240	238	(2)	25	44	19
Pleasants	266	236	(30)	48	49	1
Pocahontas	248	215	(33)	72	64	(8)
Preston	957	967	10	172	170	(2)
Putnam	1,726	1,748	22	426	383	(43)
Raleigh	1,908	1,943	35	376	456	80
Randolph	832	818	(14)	181	242	61
Ritchie	320	304	(16)	49	105	56
Roane	459	441	(18)	68	56	(12)
Summers	239	212	(27)	18	35	17
Taylor	386	396	10	56	76	20
Tucker	185	180	(5)	66	44	(22)
Tyler	313	332	19	36	59	23
Upshur	751	719	(32)	213	160	(53)
Wayne	1,532	1,441	(91)	186	191	5
Webster	252	214	(38)	63	54	(9)
Wetzel	613	552	(61)	89	82	(7)
Wirt	139	131	(8)	77	61	(16)
Wood	2,380	2,392	12	562	588	26
Wyoming	856	882	26	88	128	40
Total	50,500	49,827	(673)	10,038	10,277	239

OSF
12/15/09
Enrollment Factor C

**COMPARISON OF ENROLLMENT FACTORS
AS OF SECOND SCHOOL MONTH
2008-09 AND 2009-10**

County	Certified Adult Students			Net Enrollment (With Certified Adults)		
	2008-09	2009-10	Increase/ Decrease	2008-09	2009-10	Increase/ Decrease
Barbour	0.50	1.25	0.75	2,494.14	2,476.52	(17.61)
Berkeley	3.75	6.50	2.75	17,040.34	17,237.60	197.26
Boone	0.50	0.50	-	4,620.50	4,665.00	44.50
Braxton	-	2.50	2.50	2,229.62	2,229.62	(56.50)
Brooke	-	-	-	3,396.20	3,391.21	(4.99)
Cabell	3.00	6.70	3.70	12,496.10	12,522.10	26.00
Calhoun	8.75	2.90	(5.85)	1,128.55	1,099.90	(28.65)
Clay	-	-	-	2,026.00	2,043.00	17.00
Doddridge	2.62	3.25	0.63	1,189.02	1,152.95	(36.07)
Fayette	5.40	0.55	(4.85)	6,782.80	6,727.75	(55.05)
Gilmer	0.82	0.85	0.03	941.82	938.65	(3.17)
Grant	4.55	4.10	(0.45)	1,979.55	1,939.05	(40.50)
Greenbrier	-	-	-	5,183.60	5,282.40	98.80
Hampshire	-	-	-	3,669.50	3,596.00	(73.50)
Hancock	5.75	4.10	(1.65)	4,302.25	4,287.00	(15.25)
Hardy	2.15	1.75	(0.40)	2,316.85	2,301.55	(15.30)
Harrison	35.05	44.20	9.15	11,208.55	11,229.14	20.59
Jackson	2.05	2.55	0.50	5,059.45	5,037.08	(22.37)
Jefferson	-	1.50	1.50	8,359.69	8,471.57	111.88
Kanawha	-	-	-	28,046.17	27,970.80	(75.37)
Lewis	1.33	2.25	0.92	2,687.33	2,634.85	(52.48)
Lincoln	5.75	-	(5.75)	3,607.95	3,622.40	14.45
Logan	3.45	2.85	(0.60)	6,502.65	6,429.05	(73.60)
Marion	12.25	20.10	7.85	8,094.85	8,094.70	(0.15)
Marshall	-	-	-	4,852.34	4,809.67	(42.67)
Mason	-	5.10	5.10	4,240.50	4,266.10	25.60
McDowell	-	1.50	1.50	3,675.00	3,671.66	(3.34)
Mercer	14.52	14.20	(0.32)	9,492.75	9,515.55	22.81
Mineral	1.25	2.25	1.00	4,533.40	4,449.31	(84.09)
Mingo	0.85	-	(0.85)	4,681.35	4,586.00	(95.35)
Monongalia	23.50	10.50	(13.00)	10,304.72	10,460.35	155.63
Monroe	-	-	-	1,931.35	1,914.75	(16.60)
Morgan	-	-	-	2,692.00	2,605.90	(86.10)
Nicholas	4.25	-	(4.25)	4,083.63	4,042.00	(41.63)
Ohio	-	-	-	5,223.30	5,218.23	(5.07)
Pendleton	1.50	0.75	(0.75)	1,100.70	1,085.25	(15.45)
Pleasants	-	7.75	7.75	1,346.00	1,306.75	(39.25)
Pocahontas	-	-	-	1,188.20	1,198.13	9.92
Preston	1.00	1.00	-	4,548.80	4,615.80	67.00
Putnam	33.50	16.50	(17.00)	9,290.75	9,458.25	167.50
Raleigh	15.05	14.25	(0.80)	12,177.35	12,220.55	43.20
Randolph	0.75	1.15	0.40	4,425.35	4,355.90	(69.45)
Ritchie	0.75	1.25	0.50	1,586.25	1,621.25	35.00
Roane	2.19	2.10	(0.09)	2,535.99	2,554.90	18.91
Summers	-	-	-	1,530.50	1,547.50	17.00
Taylor	5.90	9.30	3.40	2,415.35	2,448.30	32.95
Tucker	-	-	-	1,127.00	1,096.00	(31.00)
Tyler	1.75	1.25	(0.50)	1,471.85	1,472.65	0.80
Upshur	6.08	4.15	(1.93)	3,864.48	3,829.15	(35.33)
Wayne	-	-	-	7,691.80	7,542.30	(149.50)
Webster	-	-	-	1,533.00	1,566.70	33.70
Wetzel	3.25	-	(3.25)	2,909.25	2,850.13	(59.13)
Wirt	-	-	-	951.00	967.00	16.00
Wood	-	-	-	13,424.80	13,441.41	16.61
Wyoming	32.50	34.00	1.50	4,164.70	4,189.30	24.60
Total	246.26	235.40	(10.86)	280,413.43	280,286.61	(126.81)

OSF
12/15/09
Enrollment Factor C

PERSONNEL

**CLASSIFICATION OF PROFESSIONAL PERSONNEL
BY ASSIGNMENT AND FUNDING SOURCE (FTE BASIS)
AS OF SECOND SCHOOL MONTH
(EXCLUDING RESA PERSONNEL)
2009-10 YEAR**

Position Assignment	State Aid Eligible	Other State Funds	Federal Funds	County Funds	Donations	Other Sources	Total
Superintendent	55.00	-	-	-	-	-	55.00
Deputy, Assoc. or Asst. Supt.	56.30	-	2.00	1.50	-	-	59.80
Administrative Assistant	-	-	-	10.05	-	-	10.05
Director/Manager (Instructional)	139.90	7.73	55.27	1.00	-	-	203.90
Director/Manager (Supportive Serv)	-	-	12.80	189.20	-	-	202.00
Treasurer/Chief School Business Off.	-	-	-	54.88	-	-	54.88
Principal, Elementary	415.35	-	1.00	1.00	-	-	417.35
Principal, Middle/Junior High	125.50	-	-	-	-	-	125.50
Principal, High School	134.95	0.50	0.55	-	-	-	136.00
Principal, Combined	22.50	1.00	-	-	-	-	23.50
Asst. Principal, Elementary	51.60	-	1.00	-	-	-	52.60
Asst. Principal, Middle/Jr High	109.25	-	1.00	-	-	-	110.25
Asst. Principal, High School	202.08	1.00	0.55	-	-	-	203.63
Asst. Principal, Combined	13.50	-	-	-	-	-	13.50
Head Teacher	19.50	1.00	-	-	-	-	20.50
Academic Coach	5.20	-	89.95	1.00	-	-	96.15
Curriculum Specialist	56.81	2.00	72.78	3.00	-	-	134.59
Technology Integration Specialist	36.49	-	70.01	-	-	-	106.50
Librarian	354.28	-	1.00	-	-	0.10	355.38
Remedial Specialist	13.25	-	432.81	1.00	-	-	447.06
Counselor, Elementary	220.09	-	25.78	1.00	-	-	246.87
Counselor, Middle/Junior High	149.85	-	1.75	-	-	-	151.60
Counselor, High	273.05	1.00	6.55	-	-	-	280.60
Counselor, Combined	28.58	0.50	7.85	-	-	-	36.93
Teacher, Pre-Kindergarten	241.68	0.50	136.07	0.30	-	-	378.55
Teacher, Kindergarten	1,060.38	5.00	8.00	3.00	-	-	1,076.38
Teacher, Elementary	5,849.83	3.40	512.16	10.43	-	-	6,375.82
Teacher, Middle/Junior High	3,354.52	3.78	42.61	9.15	-	-	3,410.06
Teacher, High School	4,163.65	8.82	25.64	10.00	-	0.59	4,208.70
Teacher, Special Education	2,766.84	6.93	537.01	11.00	-	-	3,321.78
Teacher, Homebound	18.30	-	-	-	-	-	18.30
Teacher, Vocational (K-12)	923.88	6.50	15.99	13.70	-	-	960.07
Teacher, Vocational (PS)	-	72.24	-	20.26	-	-	92.50
Teacher, Vocational (Adult)	-	9.25	12.75	46.00	-	-	68.00
Teacher, Community Education	-	1.00	1.00	6.00	-	-	8.00
JROTC Instructor, Middle/Jr High	2.50	-	1.50	-	-	-	4.00
JROTC Instructor, High	34.60	-	16.40	7.50	-	-	58.50
Permanent Substitute, Elementary	10.83	-	-	-	-	-	10.83
Permanent Substitute, Middle/Jr.	6.67	-	1.00	1.00	-	-	8.67
Permanent Substitute, High	13.50	-	-	-	-	-	13.50
Speech Language Pathologist	398.47	-	56.92	-	-	-	455.39
Speech Assistant - PE	15.20	-	8.83	-	-	-	24.03
Curriculum Enrichment Instructor	-	-	-	2.00	5.00	-	7.00
Professional Accountant	-	-	1.00	21.00	-	-	22.00
Activities Director	7.50	-	-	-	-	-	7.50
Technology Systems Specialist	1.00	-	3.00	20.50	-	-	24.50
Psychologist	83.33	2.00	27.17	1.00	-	-	113.50
Registered Nurse	-	-	1.00	1.00	-	-	2.00
School Nurse (Below AB)	-	1.40	1.00	4.60	-	-	7.00
School Nurse (AB)	213.12	4.50	22.45	15.40	-	0.50	255.97
Attendance Director	41.00	1.25	6.05	1.00	-	-	49.30
Attendance Officer	11.25	-	0.50	-	-	-	11.75
Social Worker	-	-	23.20	17.10	-	-	40.30
Physical Therapist	-	-	5.15	15.00	-	-	20.15
Occupational Therapist	-	-	17.00	23.00	-	-	40.00
Athletic Trainer	1.00	-	-	1.00	-	-	2.00
Dental Hygienist	-	-	-	1.50	-	-	1.50
Audiologist	-	-	0.46	3.00	-	-	3.46
Psychometrist	-	-	1.00	2.50	-	-	3.50
Total	21,702.08	141.30	2,267.51	531.57	5.00	1.19	24,648.65

OSF

01/13/10

Classification Report 10

DISTRIBUTION OF PROFESSIONAL PERSONNEL (FTE BASIS)
 BY SALARY CLASSIFICATION AND YEARS EXPERIENCE
 ALL FUNDING SOURCES - ALL DISTRICTS
 2009-10 YEAR

Years Exp.	3rd Class	A.B.	A.B. +15	M.A.	M.A. +15	M.A. +30	M.A. +45	Doc-torate	Total
0	1.50	580.71	23.25	118.32	23.50	24.50	13.50	1.00	786.28
1	-	510.80	61.00	109.10	44.00	27.00	16.50	1.00	769.40
2	2.00	443.85	138.50	99.68	42.00	26.70	15.25	2.00	769.98
3	1.00	381.19	176.01	132.00	69.00	52.50	25.00	3.00	839.70
4	0.55	320.50	186.82	111.10	80.00	49.00	35.00	1.00	783.97
5	0.50	241.10	173.43	125.00	76.50	65.50	55.00	4.00	741.03
6	2.00	191.70	165.00	85.80	95.98	65.50	63.50	1.00	670.48
7	2.10	134.10	158.50	81.49	77.30	52.00	75.40	5.00	585.89
8	0.50	93.50	182.00	69.00	91.50	71.00	64.08	2.00	573.58
9	1.00	81.00	151.20	60.55	85.00	56.50	54.50	1.00	490.75
10	-	72.00	178.40	58.50	75.10	68.31	86.00	3.00	541.31
11	0.50	62.50	159.50	46.00	89.08	97.20	86.00	-	540.78
12	0.50	49.50	177.17	43.00	60.80	81.10	120.50	2.00	534.57
13	1.00	25.75	151.00	37.00	79.38	73.88	83.36	1.00	452.37
14	0.50	24.50	139.00	29.00	61.50	64.12	93.47	2.00	414.09
15	0.50	19.75	113.65	27.22	52.10	72.50	119.65	3.00	408.36
16	-	19.00	111.50	20.50	46.05	50.12	119.55	6.00	372.72
17	-	17.50	96.50	14.00	50.50	67.50	115.25	5.00	366.25
18	-	16.00	120.50	24.00	33.66	51.00	109.49	4.75	359.40
19	-	13.00	125.89	17.00	44.50	73.50	130.00	1.00	404.89
20	1.50	17.50	147.50	24.00	43.00	83.95	176.13	2.00	495.58
21	-	18.00	161.40	19.50	42.00	70.00	202.35	5.00	518.25
22	-	12.00	160.00	22.00	57.67	60.00	169.45	1.25	482.37
23	-	11.50	164.50	16.00	50.75	86.19	189.73	3.00	521.67
24	-	14.00	148.00	22.00	51.50	73.34	213.85	5.00	527.69
25	-	11.00	149.51	16.50	46.00	88.50	244.62	5.50	561.63
26	-	7.00	170.39	17.00	40.00	69.00	230.03	8.50	541.91
27	-	8.00	137.00	16.00	32.50	88.00	232.60	5.00	519.10
28	-	6.00	121.00	20.50	39.00	71.19	236.67	6.90	501.26
29	-	11.00	160.50	28.00	33.50	81.50	276.65	3.00	594.15
30	-	7.00	156.50	25.00	44.00	92.50	297.89	5.00	627.89
31	-	5.00	137.13	20.00	42.80	82.88	271.01	2.50	561.32
32	-	6.50	116.00	23.00	26.00	78.48	293.83	3.00	546.81
33	0.50	7.00	103.00	14.00	23.50	57.50	271.70	2.54	479.74
34	-	5.00	117.00	12.00	28.00	60.65	298.61	4.00	525.26
35+	-	27.00	283.83	48.00	73.50	180.35	770.79	23.50	1,406.97
Total	16.15	3,471.45	5,222.07	1,651.75	1,951.16	2,513.46	5,856.90	134.44	20,817.38

OSF

06/03/10

Scattergram All Personnel 10

DISTRIBUTION OF STUDENT SUPPORT PERSONNEL (FTE BASIS)
 BY SALARY CLASSIFICATION AND YEARS EXPERIENCE
 ALL FUNDING SOURCES - ALL DISTRICTS
 2009-10 YEAR

Years Exp.	3rd Class	A.B.	A.B. +15	M.A.	M.A. +15	M.A. +30	M.A. +45	Doc-torate	Total
0	-	7.25	1.00	3.95	3.00	7.50	2.50	-	25.20
1	-	6.00	-	5.00	3.15	14.00	3.00	-	31.15
2	-	2.00	-	4.00	6.00	8.00	5.00	-	25.00
3	-	9.50	2.00	1.00	2.21	14.70	11.60	-	41.01
4	-	2.00	2.22	3.00	1.00	20.21	7.10	-	35.53
5	-	1.00	2.00	2.00	7.00	16.50	2.00	-	30.50
6	-	7.25	1.50	1.00	3.50	11.21	4.35	-	28.81
7	-	2.00	1.50	-	2.00	5.60	6.00	-	17.10
8	-	4.00	1.00	1.00	1.00	7.60	5.90	-	20.50
9	-	3.00	4.00	-	3.00	5.00	5.60	-	20.60
10	-	5.00	7.00	2.00	2.00	6.00	14.00	-	36.00
11	-	1.50	-	1.00	-	6.00	13.89	-	22.39
12	-	3.00	1.00	2.00	2.00	11.00	7.00	-	26.00
13	-	3.00	3.50	-	1.00	9.10	7.50	-	24.10
14	-	-	2.50	1.00	2.00	7.00	10.30	-	22.80
15	-	4.00	5.00	-	1.00	8.50	6.00	-	24.50
16	-	-	-	0.75	-	3.60	15.35	-	19.70
17	-	1.00	5.50	-	3.00	6.00	3.40	-	18.90
18	-	5.00	1.60	2.60	-	2.00	6.00	-	17.20
19	-	5.00	2.00	1.00	5.00	2.00	6.00	-	21.00
20	-	3.25	4.00	-	2.90	3.00	14.00	-	28.15
21	-	1.00	-	-	1.60	2.00	10.00	1.00	14.60
22	-	1.00	2.00	1.00	-	5.50	15.00	-	24.50
23	-	3.00	3.50	-	1.00	3.00	12.00	-	23.50
24	-	-	4.00	-	2.00	2.00	11.00	1.00	19.00
25	-	1.00	2.50	-	-	4.00	12.50	-	20.00
26	-	-	0.50	-	-	-	10.00	-	10.50
27	-	1.00	3.00	-	-	5.00	12.00	-	21.00
28	-	1.00	1.00	-	-	2.60	10.10	-	14.70
29	-	-	1.50	1.00	-	2.00	10.50	-	15.00
30	-	-	1.25	1.00	1.00	8.00	17.00	-	28.25
31	-	-	2.00	-	2.00	3.50	11.50	-	19.00
32	-	1.00	2.00	-	-	6.00	16.95	2.60	28.55
33	-	1.00	-	2.00	1.00	4.00	15.35	-	23.35
34	-	-	-	-	2.00	1.00	10.00	1.00	14.00
35+	-	-	3.50	1.00	6.00	10.60	49.50	2.00	72.60
Total	-	84.75	74.07	37.30	67.36	233.72	379.89	7.60	884.69

OSF
 06/03/10
 Scattergram All Personnel 10

**COUNTY BOARDS OF EDUCATION
AVERAGE CONTRACTED SALARIES - ALL PROFESSIONAL PERSONNEL
(EXCLUDING RESA PERSONNEL)
2009-10 YEAR**

County	FTE	Average Salary
Barbour	210.00	\$ 45,517.54
Berkeley	1,479.55	47,324.02
Boone	452.50	47,568.32
Braxton	220.50	46,179.73
Brooke	307.50	47,374.60
Cabell	1,074.45	47,120.93
Calhoun	105.50	44,309.91
Clay	171.50	46,105.34
Doddridge	120.50	45,882.24
Fayette	609.00	47,054.62
Gilmer	88.50	44,318.35
Grant	171.50	44,062.54
Greenbrier	477.60	46,133.29
Hampshire	295.75	43,958.69
Hancock	370.00	48,700.47
Hardy	179.50	45,680.39
Harrison	938.75	47,919.59
Jackson	452.50	48,227.22
Jefferson	723.00	45,691.31
Kanawha	2,498.50	47,878.60
Lewis	231.50	46,639.58
Lincoln	336.50	45,799.88
Logan	541.00	45,957.14
Marion	704.20	46,414.79
Marshall	416.00	49,892.66
Mason	382.00	46,145.89
McDowell	354.00	47,483.50
Mercer	830.00	45,713.45
Mineral	392.50	48,077.82
Mingo	438.33	46,206.34
Monongalia	921.80	46,834.25
Monroe	178.86	43,129.69
Morgan	230.75	45,380.51
Nicholas	356.25	46,054.54
Ohio	459.25	48,457.92
Pendleton	106.32	46,051.45
Pleasants	131.50	49,446.36
Pocahontas	114.50	44,836.89
Preston	413.21	44,974.43
Putnam	795.00	49,824.11
Raleigh	1,028.80	46,557.51
Randolph	390.00	46,925.35
Ritchie	143.00	46,644.74
Roane	213.00	44,431.06
Summers	140.00	45,885.50
Taylor	195.00	47,046.36
Tucker	102.00	45,648.89
Tyler	139.00	46,819.64
Upshur	344.80	46,310.53
Wayne	665.10	44,135.75
Webster	149.00	43,614.86
Wetzel	259.00	49,217.55
Wirt	95.00	43,085.25
Wood	1,125.88	48,405.23
Wyoming	379.00	47,003.46
Total	24,648.64	\$ 46,910.34

OSF3
01/08/10

Avg Contracted Salary PE- All positions 10

**COUNTY BOARDS OF EDUCATION
AVERAGE CONTRACTED SALARIES - CLASSROOM TEACHERS
(EXCLUDING RESA PERSONNEL)
2009-10 YEAR**

County	FTE	Average Salary
Barbour	174.00	\$ 44,006.66
Berkeley	1,230.00	44,359.98
Boone	378.00	45,155.33
Braxton	180.50	43,947.60
Brooke	250.81	45,086.77
Cabell	854.95	44,914.40
Calhoun	86.00	41,719.01
Clay	146.46	43,696.93
Doddridge	90.00	43,612.50
Fayette	508.37	44,949.04
Gilmer	66.50	42,272.11
Grant	139.25	41,981.07
Greenbrier	380.10	43,780.86
Hampshire	236.75	41,249.61
Hancock	293.00	45,667.88
Hardy	145.00	43,589.13
Harrison	729.65	45,438.47
Jackson	353.25	45,979.55
Jefferson	601.50	42,820.50
Kanawha	1,988.00	45,592.10
Lewis	179.00	44,326.30
Lincoln	269.50	43,810.17
Logan	447.00	43,629.61
Marion	586.70	44,349.57
Marshall	330.50	47,784.43
Mason	319.00	44,019.34
McDowell	264.00	44,672.28
Mercer	645.00	43,712.88
Mineral	319.28	45,237.17
Mingo	334.10	43,109.90
Monongalia	711.50	44,161.31
Monroe	148.46	41,133.96
Morgan	180.00	42,436.57
Nicholas	298.25	44,091.06
Ohio	359.25	45,940.31
Pendleton	89.57	43,715.18
Pleasants	105.00	45,837.29
Pocahontas	89.75	42,517.26
Preston	336.80	43,355.66
Putnam	656.00	47,281.71
Raleigh	810.50	43,827.92
Randolph	327.50	44,702.88
Ritchie	111.50	44,314.63
Roane	177.00	43,053.37
Summers	104.50	43,426.13
Taylor	154.00	45,563.16
Tucker	82.63	43,255.57
Tyler	111.00	44,355.98
Upshur	284.30	44,393.67
Wayne	543.50	41,774.95
Webster	124.00	42,453.64
Wetzel	216.00	46,522.68
Wirt	77.00	40,216.20
Wood	917.00	45,820.75
Wyoming	324.50	44,525.52
Total	19,865.66	\$ 44,506.05

OSF3

03/10/10

Avg Contracted Salary-Teachers 10

**TEACHERS' STATE MINIMUM SALARY SCHEDULE
STATE BASIC SALARY WITHOUT EQUITY
FOR THE 2009-10 YEAR**

Years Exp.	4th Class	3rd Class	2nd Class	A.B. A.B.	A.B. +15	M.A. M.A.	M.A. +15	M.A. +30	M.A. +45	Doc- torate
0	25,651	26,311	26,575	27,827	28,588	30,355	31,116	31,877	32,638	33,673
1	25,979	26,639	26,903	28,345	29,106	30,874	31,635	32,395	33,156	34,191
2	26,308	26,967	27,231	28,864	29,625	31,392	32,153	32,914	33,675	34,710
3	26,636	27,295	27,559	29,383	30,143	31,911	32,672	33,432	34,193	35,228
4	27,208	27,867	28,131	30,145	30,906	32,674	33,435	34,195	34,956	35,991
5	27,536	28,195	28,459	30,664	31,425	33,192	33,953	34,714	35,475	36,510
6	27,864	28,523	28,787	31,182	31,943	33,711	34,472	35,232	35,993	37,028
7	28,192	28,852	29,115	31,701	32,462	34,229	34,990	35,751	36,512	37,547
8	28,520	29,180	29,444	32,219	32,980	34,748	35,509	36,269	37,030	38,065
9	28,848	29,508	29,772	32,738	33,499	35,266	36,027	36,788	37,549	38,584
10	29,177	29,836	30,100	33,258	34,018	35,786	36,547	37,308	38,068	39,103
11	29,505	30,164	30,428	33,776	34,537	36,305	37,065	37,826	38,587	39,622
12	29,833	30,492	30,756	34,295	35,055	36,823	37,584	38,345	39,105	40,140
13	30,161	30,820	31,084	34,813	35,574	37,342	38,102	38,863	39,624	40,659
14	30,489	31,148	31,412	35,332	36,092	37,860	38,621	39,382	40,142	41,177
15	30,817	31,476	31,740	35,850	36,611	38,379	39,139	39,900	40,661	41,696
16	31,145	31,804	32,068	36,369	37,129	38,897	39,658	40,419	41,179	42,214
17	31,473	32,133	32,396	36,887	37,648	39,416	40,177	40,937	41,698	42,733
18	31,801	32,461	32,725	37,406	38,167	39,934	40,695	41,456	42,217	43,252
19	32,129	32,789	33,053	37,924	38,685	40,453	41,214	41,974	42,735	43,770
20	32,457	33,117	33,381	38,443	39,204	40,971	41,732	42,493	43,254	44,289
21	32,786	33,445	33,709	38,961	39,722	41,490	42,251	43,011	43,772	44,807
22	33,114	33,773	34,037	39,480	40,241	42,008	42,769	43,530	44,291	45,326
23	33,442	34,101	34,365	39,999	40,759	42,527	43,288	44,048	44,809	45,844
24	33,770	34,429	34,693	40,517	41,278	43,046	43,806	44,567	45,328	46,363
25	34,098	34,757	35,021	41,036	41,796	43,564	44,325	45,086	45,846	46,881
26	34,426	35,085	35,349	41,554	42,315	44,083	44,843	45,604	46,365	47,400
27	34,754	35,413	35,677	42,073	42,833	44,601	45,362	46,123	46,883	47,918
28	35,082	35,742	36,005	42,591	43,352	45,120	45,880	46,641	47,402	48,437
29	35,410	36,070	36,334	43,110	43,870	45,638	46,399	47,160	47,920	48,955
30	35,738	36,398	36,662	43,628	44,389	46,157	46,917	47,678	48,439	49,474
31	36,067	36,726	36,990	44,147	44,908	46,675	47,436	48,197	48,957	49,992
32	36,395	37,054	37,318	44,665	45,426	47,194	47,955	48,715	49,476	50,511
33	36,723	37,382	37,646	45,184	45,945	47,712	48,473	49,234	49,995	51,030
34	37,051	37,710	37,974	45,702	46,463	48,231	48,992	49,752	50,513	51,548
35	37,379	38,038	38,302	46,221	46,982	48,749	49,510	50,271	51,032	52,067

Note: This schedule does not include the \$600 supplement for classroom teachers with at least 20 years of teaching experience (WVC §18A-4-2), the \$3,500 supplement for those with national certification from the National Board of Professional Teaching Standards (NBPTS) (WVC §18A-4-2a), or the \$2,500 supplement for speech-language pathologists, audiologists, counselors, school psychologists, or school nurses with national certification (WVC §18A-4-4b).

OSF
04/14/09
State Salary Schedules 10

**TEACHERS' STATE MINIMUM SALARY SCHEDULE
STATE EQUITY SUPPLEMENT SCHEDULE
FOR THE 2009-10 YEAR**

Years Exp.	4th Class	3rd Class	2nd Class	A.B. A.B.	A.B. +15	M.A. M.A.	M.A. +15	M.A. +30	M.A. +45	Doc- torate
0	1,781	1,796	1,877	2,360	2,452	2,644	2,740	2,836	2,836	2,927
1	1,819	1,863	1,946	2,429	2,521	2,713	2,809	2,905	2,905	2,996
2	1,857	1,930	2,015	2,498	2,590	2,782	2,878	2,974	2,974	3,065
3	1,895	1,997	2,084	2,567	2,659	2,851	2,947	3,043	3,043	3,134
4	1,933	2,064	2,153	2,636	2,728	2,920	3,016	3,112	3,112	3,203
5	1,971	2,131	2,222	2,705	2,797	2,989	3,085	3,181	3,181	3,272
6	2,009	2,198	2,291	2,774	2,866	3,058	3,154	3,250	3,250	3,341
7	2,047	2,265	2,360	2,843	2,935	3,127	3,223	3,319	3,319	3,410
8	2,085	2,332	2,429	2,912	3,004	3,196	3,292	3,388	3,388	3,479
9	2,123	2,399	2,498	2,981	3,073	3,265	3,361	3,457	3,457	3,548
10	2,161	2,466	2,567	3,050	3,142	3,334	3,430	3,526	3,526	3,617
11	2,199	2,533	2,636	3,119	3,211	3,403	3,499	3,595	3,595	3,686
12	2,237	2,600	2,705	3,188	3,280	3,472	3,568	3,664	3,664	3,755
13	2,275	2,667	2,774	3,257	3,349	3,541	3,637	3,733	3,733	3,824
14	2,313	2,734	2,843	3,326	3,418	3,610	3,706	3,802	3,802	3,893
15	2,351	2,801	2,912	3,395	3,487	3,679	3,775	3,871	3,871	3,962
16	2,389	2,868	2,981	3,464	3,556	3,748	3,844	3,940	3,940	4,031
17	2,427	2,935	3,050	3,533	3,625	3,817	3,913	4,009	4,009	4,100
18	2,465	3,002	3,119	3,602	3,694	3,886	3,982	4,078	4,078	4,169
19	2,503	3,069	3,188	3,671	3,763	3,955	4,051	4,147	4,147	4,238
20	2,541	3,136	3,257	3,740	3,832	4,024	4,120	4,216	4,216	4,307
21	2,579	3,203	3,326	3,809	3,901	4,093	4,189	4,285	4,285	4,376
22	2,617	3,270	3,395	3,878	3,970	4,162	4,258	4,354	4,354	4,445
23	2,655	3,337	3,464	3,947	4,039	4,231	4,327	4,423	4,423	4,514
24	2,693	3,404	3,533	4,016	4,108	4,300	4,396	4,492	4,492	4,583
25	2,731	3,471	3,602	4,085	4,177	4,369	4,465	4,561	4,561	4,652
26	2,769	3,538	3,671	4,154	4,246	4,438	4,534	4,630	4,630	4,721
27	2,807	3,605	3,740	4,223	4,315	4,507	4,603	4,699	4,699	4,790
28	2,845	3,672	3,809	4,292	4,384	4,576	4,672	4,768	4,768	4,859
29	2,883	3,739	3,878	4,361	4,453	4,645	4,741	4,837	4,837	4,928
30	2,921	3,806	3,947	4,430	4,522	4,714	4,810	4,906	4,906	4,997
31	2,959	3,873	4,016	4,499	4,591	4,783	4,879	4,975	4,975	5,066
32	2,997	3,940	4,085	4,568	4,660	4,852	4,948	5,044	5,044	5,135
33	3,035	4,007	4,154	4,637	4,729	4,921	5,017	5,113	5,113	5,204
34	3,073	4,074	4,223	4,706	4,798	4,990	5,086	5,182	5,182	5,273
35	3,111	4,141	4,292	4,775	4,867	5,059	5,155	5,251	5,251	5,342

Note: This schedule does not include the \$600 supplement for classroom teachers with at least 20 years of teaching experience (WVC §18A-4-2), the \$3,500 supplement for those with national certification from the National Board of Professional Teaching Standards (NBPTS) (WVC §18A-4-2a), or the \$2,500 supplement for speech-language pathologists, audiologists, counselors, school psychologists, or school nurses with national certification (WVC §18A-4-4b).

OSF
04/14/09
State Salary Schedules 10

**TEACHERS' STATE MINIMUM SALARY SCHEDULE
STATE TOTAL SALARY (BASIC PLUS EQUITY)
FOR THE 2009-10 YEAR**

Years Exp.	4th Class	3rd Class	2nd Class	A.B.	A.B. +15	M.A.	M.A. +15	M.A. +30	M.A. +45	Doc-torate
0	27,432	28,107	28,452	30,187	31,040	32,999	33,856	34,713	35,474	36,600
1	27,798	28,502	28,849	30,774	31,627	33,587	34,444	35,300	36,061	37,187
2	28,165	28,897	29,246	31,362	32,215	34,174	35,031	35,888	36,649	37,775
3	28,531	29,292	29,643	31,950	32,802	34,762	35,619	36,475	37,236	38,362
4	29,141	29,931	30,284	32,781	33,634	35,594	36,451	37,307	38,068	39,194
5	29,507	30,326	30,681	33,369	34,222	36,181	37,038	37,895	38,656	39,782
6	29,873	30,721	31,078	33,956	34,809	36,769	37,626	38,482	39,243	40,369
7	30,239	31,117	31,475	34,544	35,397	37,356	38,213	39,070	39,831	40,957
8	30,605	31,512	31,873	35,131	35,984	37,944	38,801	39,657	40,418	41,544
9	30,971	31,907	32,270	35,719	36,572	38,531	39,388	40,245	41,006	42,132
10	31,338	32,302	32,667	36,308	37,160	39,120	39,977	40,834	41,594	42,720
11	31,704	32,697	33,064	36,895	37,748	39,708	40,564	41,421	42,182	43,308
12	32,070	33,092	33,461	37,483	38,335	40,295	41,152	42,009	42,769	43,895
13	32,436	33,487	33,858	38,070	38,923	40,883	41,739	42,596	43,357	44,483
14	32,802	33,882	34,255	38,658	39,510	41,470	42,327	43,184	43,944	45,070
15	33,168	34,277	34,652	39,245	40,098	42,058	42,914	43,771	44,532	45,658
16	33,534	34,672	35,049	39,833	40,685	42,645	43,502	44,359	45,119	46,245
17	33,900	35,068	35,446	40,420	41,273	43,233	44,090	44,946	45,707	46,833
18	34,266	35,463	35,844	41,008	41,861	43,820	44,677	45,534	46,295	47,421
19	34,632	35,858	36,241	41,595	42,448	44,408	45,265	46,121	46,882	48,008
20	34,998	36,253	36,638	42,183	43,036	44,995	45,852	46,709	47,470	48,596
21	35,365	36,648	37,035	42,770	43,623	45,583	46,440	47,296	48,057	49,183
22	35,731	37,043	37,432	43,358	44,211	46,170	47,027	47,884	48,645	49,771
23	36,097	37,438	37,829	43,946	44,798	46,758	47,615	48,471	49,232	50,358
24	36,463	37,833	38,226	44,533	45,386	47,346	48,202	49,059	49,820	50,946
25	36,829	38,228	38,623	45,121	45,973	47,933	48,790	49,647	50,407	51,533
26	37,195	38,623	39,020	45,708	46,561	48,521	49,377	50,234	50,995	52,121
27	37,561	39,018	39,417	46,296	47,148	49,108	49,965	50,822	51,582	52,708
28	37,927	39,414	39,814	46,883	47,736	49,696	50,552	51,409	52,170	53,296
29	38,293	39,809	40,212	47,471	48,323	50,283	51,140	51,997	52,757	53,883
30	38,659	40,204	40,609	48,058	48,911	50,871	51,727	52,584	53,345	54,471
31	39,026	40,599	41,006	48,646	49,499	51,458	52,315	53,172	53,932	55,058
32	39,392	40,994	41,403	49,233	50,086	52,046	52,903	53,759	54,520	55,646
33	39,758	41,389	41,800	49,821	50,674	52,633	53,490	54,347	55,108	56,234
34	40,124	41,784	42,197	50,408	51,261	53,221	54,078	54,934	55,695	56,821
35	40,490	42,179	42,594	50,996	51,849	53,808	54,665	55,522	56,283	57,409

Note: This schedule does not include the \$600 supplement for classroom teachers with at least 20 years of teaching experience (WVC §18A-4-2), the \$3,500 supplement for those with national certification from the National Board of Professional Teaching Standards (NBPTS) (WVC §18A-4-2a), or the \$2,500 supplement for speech-language pathologists, audiologists, counselors, school psychologists, or school nurses with national certification (WVC §18A-4-4b).

OSF
04/14/09
State Salary Schedules 10

**PRINCIPALS AND ASSISTANT PRINCIPALS
STATE MINIMUM SALARY INCREMENT SCHEDULE
FOR THE 2009-10 YEAR**

Degree Classification	A.B.	A.B. +15	M.A.	M.A. +15	M.A. +30	M.A. +45	Doc- torate
State Basic Salary	27,827	28,588	30,355	31,116	31,877	32,638	33,673

PRINCIPALS SALARY INCREMENT SCHEDULE								
Number Teachers Supervised	Rate	A.B.	A.B. +15	M.A.	M.A. +15	M.A. +30	M.A. +45	Doc- torate
1 - 7	11.00%	3,061	3,145	3,339	3,423	3,506	3,590	3,704
8 - 14	11.50%	3,200	3,288	3,491	3,578	3,666	3,753	3,872
15 - 24	12.00%	3,339	3,431	3,643	3,734	3,825	3,917	4,041
25 - 38	12.50%	3,478	3,574	3,794	3,890	3,985	4,080	4,209
39 - 57	13.00%	3,618	3,716	3,946	4,045	4,144	4,243	4,377
58 - Up	13.50%	3,757	3,859	4,098	4,201	4,303	4,406	4,546

ASSISTANT PRINCIPALS SALARY INCREMENT SCHEDULE								
Number Teachers Supervised	Rate	A.B.	A.B. +15	M.A.	M.A. +15	M.A. +30	M.A. +45	Doc- torate
1 - 7	5.50%	1,530	1,572	1,670	1,711	1,753	1,795	1,852
8 - 14	5.75%	1,600	1,644	1,745	1,789	1,833	1,877	1,936
15 - 24	6.00%	1,670	1,715	1,821	1,867	1,913	1,958	2,020
25 - 38	6.25%	1,739	1,787	1,897	1,945	1,992	2,040	2,105
39 - 57	6.50%	1,809	1,858	1,973	2,023	2,072	2,121	2,189
58 - Up	6.75%	1,878	1,930	2,049	2,100	2,152	2,203	2,273

Notes: (1) Reference - West Virginia Code §18A-4-3.

OSF
4/14/09
State Salary Schedules 10

**SUMMARY OF INCREASES TO TEACHERS
STATE BASIC SALARY SCHEDULE
1975-76 THROUGH 2009-10**

	A.B.	A.B. +15	M.A.	M.A. +15	M.A. +30	M.A. +45(d)	Doc- torate	Exp. Incr.
Basic salary 1975-76	7,655	7,959	8,263	8,565	8,869	-	9,172	146
Basic salary increases:								
1976-77	1,000	1,000	1,000	1,000	1,000	-	1,000	-
1977-78	-	86	172	260	346	-	433	59
1978-79	-	110	220	330	440	-	550	52
1979-80	150	250	350	450	550	-	650	64
1980-81	950	950	950	950	950	-	950	-
1981-82	1,900	1,900	1,900	1,900	1,900	-	1,900	-
1982-83	-	-	-	-	-	-	-	-
1983-84	-	-	-	-	-	-	-	-
1984-85 (a)	800	800	800	800	800	-	800	40
1985-86 (b)	200	300	400	500	600	-	700	20
1986-87	600	600	600	600	600	-	600	-
1987-88	-	-	-	-	-	-	-	-
1988-89	-	-	-	-	-	-	-	-
1989-90 (c)	663	698	733	768	803	-	838	19
1990-91	2,000	2,000	2,000	2,000	2,000	-	2,000	-
1991-92	1,000	1,000	1,000	1,000	1,000	-	1,000	-
1992-93	2,000	2,000	2,973	2,973	2,973	-	3,238	-
1993-94	-	-	-	-	-	-	-	-
1994-95 (d)	500	500	500	500	500	24,066	1,235	40
1995-96	-	-	-	-	-	-	-	-
1996-97	500	500	500	500	500	500	500	25
1997-98	-	-	-	-	-	-	-	-
1998-99	756	756	756	756	756	756	756	-
1999-2000	756	756	756	756	756	756	756	-
2000-01	756	756	756	756	756	756	756	-
2001-02 (e)	1,000	1,000	1,000	1,000	1,000	1,000	1,000	-
2002-03 (f)	804	804	804	804	804	804	804	36
2003-04	-	-	-	-	-	-	-	-
2004-05	-	-	-	-	-	-	-	-
2005-06 (g)	1,350	1,350	1,350	1,350	1,350	1,350	1,350	-
2006-07 (g)	-	-	-	-	-	-	-	-
2007-08 (g)(h)	887	913	972	998	1,024	1,050	1,085	18
2008-09 (g)	1,600	1,600	1,600	1,600	1,600	1,600	1,600	-
2009-10	-	-	-	-	-	-	-	-
Total increase	20,172	20,629	22,092	22,551	23,008	32,638	24,501	373
Basic salary 2009-10	27,827	28,588	30,355	31,116	31,877	32,638	33,673	519
Annual experience increment:								
Years 1 - 3	519	519	519	519	519	519	519 (h)	
Year 4	763	763	763	763	763	763	763	
Years 5 - 35	519	519	519	519	519	519	519	
Max. years for increase	35	35	35	35	35	35	35	
Max incremental increase	18,394	18,394	18,394	18,394	18,394	18,394	18,394	
Basic salary with max exper- ience increment 2009-10	46,221	46,982	48,749	49,510	50,271	51,032	52,067	

Notes:

- (a) Salary equity began in 1984-85 with experience increment increases of \$69/yr; salaries shown do not include salary equity.
- (b) Classroom teachers with 20 years of teaching experience provided an additional \$600 annually.
- (c) The 5% increase in basic salaries in 1988-89 was provided the second half of the year.
- (d) MA+45 salary classification created beginning with the 1994-95 year.
- (e) In addition to the \$1,000 increase in basic salaries, the \$534 experience increment (\$465 basic salaries plus \$69 equity) was extended to those with 31 - 35 years of experience; all increases were made effective the 2nd quarter.
- (f) In addition to the \$804 increase in basic salaries, the experience increment was increased from \$534 to \$570 (\$501 basic salaries plus \$69 equity), and the \$570 experience increment was extended to those with 29 and 30 years of experience.
- (g) In addition to the \$1,350 increase in basic salary, effective the first day of the second quarter, the experience increment of \$570 (\$501 basic salary plus \$69 equity) was extended one year for the 2005-06 year, three years for the 2006-07 year, three additional years for the 2007-08 year, and the salary schedule was completely filled in from 1 - 35 years for the 2008-09 year.
- (h) In addition to the increases discussed in the preceding note, basic salaries increased by 3.5% for the 2007-08 year, which also increased the experience increment by \$17.54 per year, making the total experience increment \$588 per year (\$519 in basic salaries plus \$69 equity), except between the 3rd and 4th year where the total increase is \$832 (\$763 in basic salaries plus \$69 equity).

TABLE A2.1
A PROFILE OF WEST VIRGINIA'S PUBLIC SCHOOL EDUCATORS, 2007-2010

	2007-2008		2008-2009		2009-2010	
	NUMBER	PERCENTAGE	NUMBER	PERCENTAGE	NUMBER	PERCENTAGE
TOTAL EDUCATORS	N = 24,305		N = 24,366		N = 24,609	
AGE DISTRIBUTION Number and Percent in Age Group:						
Over 60	1188	4.89%	1413	5.80%	1694	6.88%
55-60	5,454	22.44%	5456	22.39%	5341	21.70%
50-54	4,890	20.12%	4469	18.34%	4159	16.90%
40-49	5,723	23.55%	5647	23.18%	5599	22.75%
30-39	4,410	18.14%	4561	18.72%	4864	19.77%
20-29	2,640	10.86%	2820	11.57%	2950	11.99%
STATE AVERAGE AGE	46.00 Years		45.00 Years		45.00 Years	
TOTAL YEARS EXPERIENCE IN EDUCATION	N = 24,305		N = 24,366		N = 24,609	
Number & Years:						
31 & up	3,860	15.88%	3941	16.17%	4019	16.33%
26-30	3,649	15.01%	3352	13.76%	3161	12.84%
21-25	3,275	13.47%	3136	12.87%	3025	12.29%
16-20	2,725	11.21%	2559	10.50%	2400	9.75%
11-15	2,461	10.13%	2647	10.86%	2809	11.41%
6-10	3,222	13.26%	3234	13.27%	3458	14.05%
4-5	1,459	6.00%	1664	6.83%	1847	7.51%
0-3	3,655	15.04%	3835	15.74%	3891	15.81%
STATE AVERAGE EXPERIENCE	17.58		17.24		19.96	
SALARY CLASSIFICATION STATUS	N = 24,305		N = 24,366		N = 24,609	
Number and Percent Having:						
Doctorate	150	0.61%	151	0.62%	157	0.64%
Master's +45	7,483	30.79%	7327	30.07%	7169	29.13%
Master's +30	3,178	13.06%	3133	12.86%	3127	12.71%
Master's +15	2,230	9.18%	2226	9.14%	2311	9.39%
Master's	1,781	7.33%	1864	7.65%	1994	8.10%
Bachelor's +15	5,764	23.72%	5749	23.59%	5715	23.22%
Bachelor's	3,673	15.11%	3866	15.87%	4098	16.65%
No Degree	44	0.18%	49	0.20%	39	0.16%

TABLE A2.2
A PROFILE OF WEST VIRGINIA'S PUBLIC SCHOOL ADMINISTRATORS, 2007-2010

	2006-2007		2007-2008		2008-2009	
	NUMBER	PERCENTAGE	NUMBER	PERCENTAGE	NUMBER	PERCENTAGE
TOTAL ADMINISTRATORS	N = 1,928		N= 1,955		N= 1,939	
AGE DISTRIBUTION Number and Percent in Age Group:						
Over 60	136	7.05%	183	9.17%	217	11.19%
55-60	620	32.16%	586	29.37%	557	28.73%
50-54	431	22.35%	417	20.90%	408	21.04%
40-49	487	25.26%	495	24.81%	470	24.24%
30-39	218	11.31%	239	11.98%	263	13.56%
20-29	36	1.87%	35	1.75%	24	1.24%
STATE AVERAGE AGE	50.00 Years		50.00 Years		50.00 Years	
TOTAL YRS EXPERIENCE IN EDUCATION Number & Years:	N = 1,928		N= 1,955		N= 1,939	
31 & up	611	31.69%	633	31.73%	636	32.80%
26 - 30	369	19.14%	330	16.54%	319	16.45%
21 - 25	310	16.08%	323	16.19%	301	15.52%
16 - 20	219	11.36%	221	11.08%	219	11.29%
11-15	189	9.80%	191	9.57%	197	10.16%
6-10	154	7.99%	163	8.17%	180	9.28%
4-5	34	1.76%	49	2.46%	42	2.17%
0-3	42	2.18%	45	2.26%	45	2.32%
STATE AVERAGE EXPERIENCE	24.10 Years		23.95 Years		23.93 Years	
SALARY CLASSIFICATION STATUS Number & Percent Having:	N = 1,928		N= 1,955		N= 1,939	
Doctorate	75	3.89%	68	3.41%	76	3.92%
Master's +45	1,240	64.31%	1248	62.56%	1240	63.95%
Master's +30	298	15.46%	308	15.44%	316	16.30%
Master's +15	106	5.50%	114	5.71%	110	5.67%
Master's	98	5.08%	91	4.56%	95	4.90%
Bachelor's +15	42	2.18%	42	2.11%	34	1.75%
Bachelor's	65	3.37%	79	3.96%	66	3.40%
No Degree	3	0.16%	3	0.15%	2	0.10%

TABLE A2.3
AGE DISTRIBUTION OF EMPLOYED WEST VIRGINIA EDUCATORS
2009-2010 SCHOOL YEAR
BY COUNTY

COUNTY	NUMBER OF COUNTY EDUCATORS	Number of Educators within Span and Percentage of Total												Average Age (Years)
		Ages 20-29		Ages 30-39		Ages 40-49		Ages 50-54		Ages 55-60		Over 60		
		N	%	N	%	N	%	N	%	N	%	N	%	
BARBOUR	212	27	12.74	43	20.28	58	27.36	46	21.70	30	14.15	8	3.77	44
BERKELEY	1495	253	16.92	383	25.62	339	22.68	178	11.91	245	16.39	97	6.49	43
BOONE	446	52	11.66	93	20.85	105	23.54	85	19.06	90	20.18	21	4.71	45
BRAXTON	219	24	10.96	33	15.07	57	26.03	44	20.09	51	23.29	10	4.57	46
BROOKE	307	35	11.40	55	17.92	54	17.59	56	18.24	88	28.66	19	6.19	46
CABELL	1064	128	12.03	226	21.24	234	21.99	158	14.85	239	22.46	79	7.42	45
CALHOUN	106	20	18.87	19	17.92	29	27.36	21	19.81	14	13.21	3	2.83	43
CLAY	170	21	12.35	35	20.59	51	30.00	30	17.65	26	15.29	7	4.12	44
DODDRIDGE	119	16	13.45	19	15.97	34	28.57	21	17.65	27	22.69	2	1.68	45
FAYETTE	603	60	9.95	105	17.41	131	21.72	109	18.08	156	25.87	42	6.97	47
GILMER	88	11	12.50	15	17.05	25	28.41	13	14.77	17	19.32	7	7.95	46
GRANT	172	29	16.86	32	18.60	40	23.26	27	15.70	34	19.77	10	5.81	44
GREENBRIER	477	57	11.95	90	18.87	92	19.29	81	16.98	112	23.48	45	9.43	46
HAMPSHIRE	290	44	15.17	75	25.86	67	23.10	36	12.41	53	18.28	15	5.17	43
HANCOCK	364	38	10.44	68	18.68	65	17.86	49	13.46	112	30.77	32	8.79	47
HARDY	179	23	12.85	36	20.11	42	23.46	37	20.67	31	17.32	10	5.59	45
HARRISON	970	104	10.72	192	19.79	219	22.58	187	19.28	199	20.52	69	7.11	46
JACKSON	455	43	9.45	101	22.20	126	27.69	90	19.78	74	16.26	21	4.62	45
JEFFERSON	711	119	16.74	146	20.53	169	23.77	98	13.78	117	16.46	62	8.72	44
KANAWHA	2489	251	10.08	457	18.36	515	20.69	396	15.91	586	23.54	284	11.41	47
LEWIS	228	15	6.58	37	16.23	66	28.95	46	20.18	51	22.37	13	5.70	47
LINCOLN	333	47	14.11	63	18.92	80	24.02	49	14.71	71	21.32	23	6.91	45
LOGAN	537	58	10.80	94	17.50	124	23.09	86	16.01	133	24.77	42	7.82	46
MARION	707	84	11.88	134	18.95	148	20.93	136	19.24	160	22.63	45	6.36	46
MARSHALL	413	36	8.72	86	20.82	79	19.13	52	12.59	123	29.78	37	8.96	47
MASON	383	38	9.92	87	22.72	95	24.80	61	15.93	79	20.63	23	6.01	45
MCDOWELL	349	33	9.46	65	18.62	64	18.34	71	20.34	85	24.36	31	8.88	47
MERCER	835	91	10.90	161	19.28	167	20.00	159	19.04	189	22.63	68	8.14	46
MINERAL	396	50	12.63	80	20.20	75	18.94	57	14.39	101	25.51	33	8.33	46
MINGO	433	51	11.78	64	14.78	100	23.09	83	19.17	104	24.02	31	7.16	46
MONONGALIA	899	105	11.68	200	22.25	212	23.58	146	16.24	190	21.13	46	5.12	45
MONROE	177	28	15.82	39	22.03	50	28.25	32	18.08	22	12.43	6	3.39	43
MORGAN	232	41	17.67	63	27.16	52	22.41	25	10.78	40	17.24	11	4.74	42
NICHOLAS	352	33	9.38	56	15.91	89	25.28	62	17.61	82	23.30	30	8.52	47
OHIO	482	56	11.62	121	25.10	93	19.29	68	14.11	119	24.69	25	5.19	45
PENDLETON	108	22	20.37	13	12.04	18	16.67	24	22.22	25	23.15	6	5.56	45
PLEASANTS	132	13	9.85	22	16.67	37	28.03	24	18.18	29	21.97	7	5.30	46
POCAHONTAS	116	13	11.21	22	18.97	36	31.03	14	12.07	26	22.41	5	4.31	45
PRESTON	407	45	11.06	64	15.72	98	24.08	58	14.25	108	26.54	34	8.35	46
PUTNAM	792	81	10.23	172	21.72	195	24.62	136	17.17	152	19.19	56	7.07	45
RALEIGH	1035	114	11.01	216	20.87	232	22.42	189	18.26	230	22.22	54	5.22	45
RANDOLPH	386	37	9.59	62	16.06	93	24.09	77	19.95	102	26.42	15	3.89	47
RITCHIE	141	22	15.60	23	16.31	42	29.79	27	19.15	22	15.60	5	3.55	43
ROANE	210	26	12.38	49	23.33	64	30.48	39	18.57	26	12.38	6	2.86	43
SUMMERS	138	14	10.14	25	18.12	27	19.57	35	25.36	29	21.01	8	5.80	46
TAYLOR	196	21	10.71	34	17.35	40	20.41	40	20.41	45	22.96	16	8.16	46
TUCKER	99	9	9.09	24	24.24	24	24.24	17	17.17	20	20.20	5	5.05	45
TYLER	137	23	16.79	22	16.06	29	21.17	37	27.01	22	16.06	4	2.92	44
UPSHUR	343	46	13.41	71	20.70	78	22.74	61	17.78	69	20.12	18	5.25	44
WAYNE	653	113	17.30	151	23.12	151	23.12	95	14.55	114	17.46	29	4.44	43
WEBSTER	148	18	12.16	21	14.19	42	28.38	37	25.00	28	18.92	2	1.35	45
WETZEL	264	34	12.88	39	14.77	48	18.18	53	20.08	73	27.65	17	6.44	47
WIRT	95	23	24.21	20	21.05	21	22.11	16	16.84	10	10.53	5	5.26	42
WOOD	1140	114	10.00	201	17.63	270	23.68	202	17.72	286	25.09	67	5.88	46
WYOMING	377	42	11.14	40	10.61	108	28.65	83	22.02	76	20.16	28	7.43	47
Total Personnel	24,609	2,951	11.99	4,864	19.77	5,599	22.75	4,159	16.90	5,342	21.71	1,694	6.88	45

TABLE A2.4
AGE DISTRIBUTION OF EMPLOYED
WEST VIRGINIA ADMINISTRATORS
2009-2010 SCHOOL YEAR
BY COUNTY

COUNTY	NUMBER OF ADMINISTRATORS	Number of Administrators within Span and Percentage of Total												Average Age (Years)
		Ages 20-29		Ages 30-39		Ages 40-49		Ages 50-54		Ages 55-60		Over 60		
		N	%	N	%	N	%	N	%	N	%	N	%	
BARBOUR	19	1	5.3%	4	21.1%	8	42.1%	5	26.3%	1	5.3%	0	0.0%	45
BERKELEY	102	2	2.0%	23	22.5%	25	24.5%	13	12.7%	29	28.4%	10	9.8%	48
BOONE	39	0	0.0%	6	15.4%	13	33.3%	9	23.1%	10	25.6%	1	2.6%	48
BRAXTON	19	0	0.0%	4	21.1%	4	21.1%	4	21.1%	5	26.3%	2	10.5%	50
BROOKE	22	0	0.0%	2	9.1%	5	22.7%	5	22.7%	8	36.4%	2	9.1%	51
CABELL	84	1	1.2%	11	13.1%	27	32.1%	14	16.7%	23	27.4%	8	9.5%	49
CALHOUN	11	0	0.0%	3	27.3%	4	36.4%	2	18.2%		0.0%	2	18.2%	46
CLAY	17	0	0.0%	5	29.4%	5	29.4%	3	17.6%	2	11.8%	2	11.8%	47
DODDRIDGE	10	0	0.0%	0	0.0%	1	10.0%	3	30.0%	6	60.0%	0	0.0%	54
FAYETTE	52	0	0.0%	9	17.3%	12	23.1%	11	21.2%	16	30.8%	4	7.7%	50
GILMER	10	1	10.0%	0	0.0%	2	20.0%	3	30.0%	4	40.0%	0	0.0%	50
GRANT	13	0	0.0%	0	0.0%	4	30.8%	3	23.1%	6	46.2%	0	0.0%	52
GREENBRIER	33	0	0.0%	4	12.1%	8	24.2%	7	21.2%	11	33.3%	3	9.1%	51
HAMPSHIRE	20	0	0.0%	2	10.0%	6	30.0%	3	15.0%	7	35.0%	2	10.0%	50
HANCOCK	27	0	0.0%	1	3.7%	5	18.5%	6	22.2%	11	40.7%	4	14.8%	53
HARDY	13	0	0.0%	1	7.7%	3	23.1%	2	15.4%	6	46.2%	1	7.7%	52
HARRISON	90	3	3.3%	18	20.0%	17	18.9%	15	16.7%	22	24.4%	15	16.7%	49
JACKSON	35	0	0.0%	11	31.4%	6	17.1%	7	20.0%	11	31.4%	0	0.0%	47
JEFFERSON	53	1	1.9%	11	20.8%	10	18.9%	7	13.2%	20	37.7%	4	7.5%	49
KANAWHA	193	3	1.6%	34	17.6%	37	19.2%	36	18.7%	57	29.5%	26	13.5%	50
LEWIS	18	0	0.0%	4	22.2%	4	22.2%	6	33.3%	3	16.7%	1	5.6%	48
LINCOLN	25	0	0.0%	1	4.0%	9	36.0%	6	24.0%	8	32.0%	1	4.0%	51
LOGAN	45	0	0.0%	2	4.4%	9	20.0%	10	22.2%	17	37.8%	7	15.6%	53
MARION	44	0	0.0%	4	9.1%	10	22.7%	12	27.3%	11	25.0%	7	15.9%	51
MARSHALL	30	0	0.0%	8	26.7%	7	23.3%	4	13.3%	6	20.0%	5	16.7%	49
MASON	32	0	0.0%	5	15.6%	10	31.3%	6	18.8%	7	21.9%	4	12.5%	49
MCDOWELL	33	0	0.0%	3	9.1%	6	18.2%	9	27.3%	12	36.4%	3	9.1%	51
MERCER	53	2	3.8%	2	3.8%	10	18.9%	16	30.2%	18	34.0%	5	9.4%	52
MINERAL	32	0	0.0%	3	9.4%	8	25.0%	4	12.5%	9	28.1%	8	25.0%	52
MINGO	40	1	2.5%	3	7.5%	11	27.5%	8	20.0%	14	35.0%	3	7.5%	50
MONONGALIA	60	0	0.0%	8	13.3%	9	15.0%	13	21.7%	24	40.0%	6	10.0%	52
MONROE	13	0	0.0%	2	15.4%	6	46.2%	1	7.7%	2	15.4%	2	15.4%	48
MORGAN	21	0	0.0%	6	28.6%	6	28.6%	4	19.0%	4	19.0%	1	4.8%	46
NICHOLAS	37	0	0.0%	3	8.1%	11	29.7%	7	18.9%	12	32.4%	4	10.8%	51
OHIO	35	1	2.9%	7	20.0%	7	20.0%	6	17.1%	10	28.6%	4	11.4%	49
PENDLETON	10	0	0.0%	1	10.0%	2	20.0%	5	50.0%	1	10.0%	1	10.0%	51
PLEASANTS	12	0	0.0%	1	8.3%	4	33.3%	5	41.7%	1	8.3%	1	8.3%	49
POCAHONTAS	10	0	0.0%	0	0.0%	3	30.0%	1	10.0%	4	40.0%	2	20.0%	54
PRESTON	29	0	0.0%	4	13.8%	6	20.7%	4	13.8%	9	31.0%	6	20.7%	52
PUTNAM	67	1	1.5%	3	4.5%	20	29.9%	15	22.4%	20	29.9%	8	11.9%	51
RALEIGH	84	2	2.4%	6	7.1%	21	25.0%	18	21.4%	26	31.0%	11	13.1%	51
RANDOLPH	29	0	0.0%	0	0.0%	6	20.7%	8	27.6%	12	41.4%	3	10.3%	53
RITCHIE	12	0	0.0%	1	8.3%	7	58.3%	2	16.7%	1	8.3%	1	8.3%	47
ROANE	16	0	0.0%	3	18.8%	4	25.0%	6	37.5%	3	18.8%	0	0.0%	48
SUMMERS	10	0	0.0%	1	10.0%	2	20.0%	5	50.0%	2	20.0%	0	0.0%	48
TAYLOR	15	1	6.7%	3	20.0%	1	6.7%	6	40.0%	2	13.3%	2	13.3%	49
TUCKER	9	1	11.1%	1	11.1%	1	11.1%	2	22.2%	4	44.4%	0	0.0%	48
TYLER	11	0	0.0%	4	36.4%	2	18.2%	3	27.3%	1	9.1%	1	9.1%	46
UPSHUR	25	0	0.0%	3	12.0%	8	32.0%	7	28.0%	2	8.0%	5	20.0%	49
WAYNE	59	0	0.0%	8	13.6%	21	35.6%	11	18.6%	14	23.7%	5	8.5%	49
WEBSTER	13	1	7.7%	1	7.7%	3	23.1%	4	30.8%	3	23.1%	1	7.7%	49
WETZEL	19	1	5.3%	1	5.3%	4	21.1%	4	21.1%	5	26.3%	4	21.1%	52
WIRT	7	0	0.0%	1	14.3%	2	28.6%	4	57.1%		0.0%	0	0.0%	48
WOOD	92	1	1.1%	10	10.9%	23	25.0%	20	21.7%	25	27.2%	13	14.1%	51
WYOMING	30	0	0.0%	1	3.3%	5	16.7%	8	26.7%	10	33.3%	6	20.0%	54
Total State Personnel	1939	24	1.2%	263	13.6%	470	24.2%	408	21.0%	557	28.7%	217	11.2%	50

TABLE A2.5
EXPERIENCE OF EMPLOYED WEST VIRGINIA EDUCATORS
2009-2010 SCHOOL YEAR
BY COUNTY

COUNTY	NUMBER OF EDUCATORS	Number of Administrators within Span and Percentage of Total																Average Years
		Years 0-3		Years 4-5		Years 6-10		Years 11-15		Years 16-20		Years 21-25		Years 26-30		Years 31 & Up		
		N	%	N	%	N	%	N	%	N	%	N	%	N	%	N	%	
BARBOUR	212	22	10.4%	18	8.5%	30	14.2%	29	13.7%	20	9.4%	29	13.7%	33	15.6%	31	14.6%	17.69
BERKELEY	1,495	313	20.9%	140	9.4%	295	19.7%	173	11.6%	148	9.9%	124	8.3%	121	8.1%	181	12.1%	13.93
BOONE	447	84	18.8%	34	7.6%	47	10.5%	42	9.4%	73	16.3%	58	13.0%	62	13.9%	47	10.5%	16.08
BRAXTON	219	28	12.8%	20	9.1%	24	11.0%	28	12.8%	23	10.5%	24	11.0%	33	15.1%	39	17.8%	17.86
BROOKE	307	42	13.7%	19	6.2%	39	12.7%	34	11.1%	20	6.5%	30	9.8%	56	18.2%	67	21.8%	19.07
CABELL	1,064	170	16.0%	80	7.5%	152	14.3%	132	12.4%	105	9.9%	141	13.3%	142	13.3%	142	13.3%	16.45
CALHOUN	106	28	26.4%	9	8.5%	9	8.5%	8	7.5%	13	12.3%	12	11.3%	16	15.1%	11	10.4%	14.69
CLAY	170	32	18.8%	10	5.9%	23	13.5%	13	7.6%	20	11.8%	31	18.2%	18	10.6%	23	13.5%	16.75
DODDRIDGE	119	13	10.9%	17	14.3%	17	14.3%	9	7.6%	14	11.8%	15	12.6%	14	11.8%	20	16.8%	16.94
FAYETTE	603	82	13.6%	42	7.0%	59	9.8%	63	10.4%	68	11.3%	94	15.6%	86	14.3%	109	18.1%	18.34
GILMER	88	14	15.9%	6	6.8%	10	11.4%	8	9.1%	16	18.2%	6	6.8%	13	14.8%	15	17.0%	17.3
GRANT	172	29	16.9%	17	9.9%	31	18.0%	23	13.4%	11	6.4%	24	14.0%	13	7.6%	24	14.0%	15.1
GREENBRIER	477	98	20.5%	31	6.5%	63	13.2%	47	9.9%	35	7.3%	59	12.4%	49	10.3%	95	19.9%	16.78
HAMPSHIRE	290	51	17.6%	25	8.6%	52	17.9%	40	13.8%	31	10.7%	31	10.7%	24	8.3%	36	12.4%	14.92
HANCOCK	364	55	15.1%	28	7.7%	48	13.2%	42	11.5%	33	9.1%	37	10.2%	34	9.3%	87	23.9%	18.04
HARDY	179	20	11.2%	13	7.3%	29	16.2%	29	16.2%	17	9.5%	20	11.2%	19	10.6%	32	17.9%	17.28
HARRISON	970	117	12.1%	80	8.2%	153	15.8%	98	10.1%	99	10.2%	101	10.4%	130	13.4%	192	19.8%	18.01
JACKSON	455	70	15.4%	26	5.7%	63	13.8%	68	14.9%	48	10.5%	57	12.5%	64	14.1%	59	13.0%	16.91
JEFFERSON	711	142	20.0%	74	10.4%	135	19.0%	86	12.1%	62	8.7%	65	9.1%	62	8.7%	85	12.0%	14.21
KANAWHA	2490	355	14.3%	188	7.6%	344	13.8%	275	11.0%	241	9.7%	350	14.1%	306	12.3%	431	17.3%	17.46
LEWIS	228	23	10.1%	15	6.6%	31	13.6%	25	11.0%	26	11.4%	27	11.8%	42	18.4%	39	17.1%	18.75
LINCOLN	334	55	16.5%	22	6.6%	38	11.4%	36	10.8%	38	11.4%	46	13.8%	42	12.6%	57	17.1%	17.39
LOGAN	537	109	20.3%	35	6.5%	69	12.8%	38	7.1%	60	11.2%	74	13.8%	59	11.0%	93	17.3%	16.77
MARION	707	99	14.0%	51	7.2%	96	13.6%	87	12.3%	50	7.1%	87	12.3%	100	14.1%	137	19.4%	17.99
MARSHALL	413	39	9.4%	42	10.2%	56	13.6%	42	10.2%	24	5.8%	46	11.1%	46	11.1%	118	28.6%	19.62
MASON	383	68	17.8%	27	7.0%	58	15.1%	35	9.1%	50	13.1%	47	12.3%	43	11.2%	55	14.4%	16.25
MCDOWELL	349	64	18.3%	22	6.3%	39	11.2%	11	3.2%	31	8.9%	46	13.2%	56	16.0%	80	22.9%	18.78
MERCER	835	120	14.4%	58	6.9%	116	13.9%	113	13.5%	52	6.2%	133	15.9%	102	12.2%	141	16.9%	17.38
MINERAL	396	54	13.6%	27	6.8%	55	13.9%	56	14.1%	34	8.6%	41	10.4%	41	10.4%	88	22.2%	17.96
MINGO	433	101	23.3%	24	5.5%	39	9.0%	34	7.9%	57	13.2%	62	14.3%	60	13.9%	56	12.9%	16.24
MONONGALIA	899	142	15.8%	70	7.8%	129	14.3%	135	15.0%	96	10.7%	100	11.1%	105	11.7%	122	13.6%	16.05
MONROE	177	37	20.9%	16	9.0%	31	17.5%	16	9.0%	16	9.0%	27	15.3%	16	9.0%	18	10.2%	14.33
MORGAN	232	51	22.0%	25	10.8%	46	19.8%	29	12.5%	24	10.3%	18	7.8%	15	6.5%	24	10.3%	12.97
NICHOLAS	352	46	13.1%	30	8.5%	43	12.2%	38	10.8%	45	12.8%	46	13.1%	39	11.1%	65	18.5%	17.81
OHIO	482	58	12.0%	44	9.1%	77	16.0%	64	13.3%	41	8.5%	46	9.5%	62	12.9%	90	18.7%	17.37
PENDLETON	108	19	17.6%	5	4.6%	11	10.2%	8	7.4%	14	13.0%	12	11.1%	16	14.8%	23	21.3%	18.32
PLEASANTS	132	18	13.6%	10	7.6%	16	12.1%	19	14.4%	8	6.1%	14	10.6%	17	12.9%	30	22.7%	18.14
POCAHONTAS	116	17	14.7%	13	11.2%	11	9.5%	15	12.9%	15	12.9%	17	14.7%	9	7.8%	19	16.4%	16.61
PRESTON	407	74	18.2%	14	3.4%	48	11.8%	46	11.3%	44	10.8%	57	14.0%	55	13.5%	69	17.0%	17.6
PUTNAM	792	97	12.2%	54	6.8%	121	15.3%	109	13.8%	95	12.0%	88	11.1%	116	14.6%	112	14.1%	17.2
RALEIGH	1,035	159	15.4%	79	7.6%	140	13.5%	124	12.0%	82	7.9%	137	13.2%	168	16.2%	146	14.1%	16.98
RANDOLPH	386	50	13.0%	28	7.3%	37	9.6%	48	12.4%	24	6.2%	49	12.7%	82	21.2%	68	17.6%	18.91
RITCHIE	141	28	19.9%	7	5.0%	15	10.6%	18	12.8%	15	10.6%	24	17.0%	16	11.3%	18	12.8%	16.51
ROANE	210	36	17.1%	16	7.6%	20	9.5%	25	11.9%	25	11.9%	36	17.1%	28	13.3%	24	11.4%	16.65
SUMMERS	138	17	12.3%	16	11.6%	16	11.6%	10	7.2%	8	5.8%	17	12.3%	31	22.5%	23	16.7%	18.19
TAYLOR	196	25	12.8%	9	4.6%	22	11.2%	18	9.2%	22	11.2%	27	13.8%	39	19.9%	34	17.3%	18.93
TUCKER	99	9	9.1%	8	8.1%	20	20.2%	14	14.1%	9	9.1%	11	11.1%	10	10.1%	18	18.2%	17
TYLER	137	24	17.5%	13	9.5%	14	10.2%	9	6.6%	11	8.0%	14	10.2%	27	19.7%	25	18.2%	17.89
UPSHUR	343	47	13.7%	14	4.1%	57	16.6%	39	11.4%	44	12.8%	37	10.8%	56	16.3%	49	14.3%	17.36
WAYNE	653	135	20.7%	45	6.9%	106	16.2%	87	13.3%	68	10.4%	59	9.0%	68	10.4%	85	13.0%	14.83
WEBSTER	148	28	18.9%	6	4.1%	25	16.9%	14	9.5%	19	12.8%	18	12.2%	24	16.2%	14	9.5%	15.82
WETZEL	264	37	14.0%	14	5.3%	28	10.6%	26	9.8%	24	9.1%	25	9.5%	44	16.7%	66	25.0%	19.72
WIRT	95	21	22.1%	10	10.5%	15	15.8%	11	11.6%	11	11.6%	11	11.6%	11	11.6%	5	5.3%	13.44
WOOD	1,140	161	14.1%	73	6.4%	160	14.0%	128	11.2%	91	8.0%	149	13.1%	155	13.6%	223	19.6%	18.03
WYOMING	377	59	15.6%	28	7.4%	30	8.0%	35	9.3%	30	8.0%	70	18.6%	66	17.5%	59	15.6%	18.43
Personnel	24,612	3,892	15.8%	1,847	7.5%	3,458	14.1%	2,809	11.4%	2,400	9.8%	3,026	12.3%	3,161	12.8%	4,019	16.3%	17.02

TABLE A2.6
EXPERIENCE OF EMPLOYED
WEST VIRGINIA ADMINISTRATORS
2009-2010 SCHOOL YEAR
BY COUNTY

COUNTY	NUMBER OF ADMINISTRATORS	Number of Administrators within Span and Percentage of Total																Average Years
		Years 0-3		Years 4-5		Years 6-10		Years 11-15		Years 16-20		Years 21-25		Years 26-30		Years 31 & Up		
		N	%	N	%	N	%	N	%	N	%	N	%	N	%	N	%	
BARBOUR	19	0	0.0%	1	5.3%	5	26.3%	1	5.3%	1	5.3%	6	31.6%	4	21.1%	1	5.3%	18.79
BERKELEY	102	1	1.0%	3	2.9%	14	13.7%	17	16.7%	10	9.8%	10	9.8%	10	9.8%	37	36.3%	22.63
BOONE	39	0	0.0%	2	5.1%	4	10.3%	1	2.6%	6	15.4%	7	17.9%	10	25.6%	9	23.1%	23.23
BRAXTON	19	1	5.3%	1	5.3%	1	5.3%	1	5.3%	3	15.8%	3	15.8%	2	10.5%	7	36.8%	24.26
BROOKE	22	0	0.0%	0	0.0%	1	4.5%	4	18.2%	3	13.6%	2	9.1%	5	22.7%	7	31.8%	24.64
CABELL	84	4	4.8%	2	2.4%	4	4.8%	10	11.9%	12	14.3%	16	19.0%	13	15.5%	23	27.4%	23.05
CALHOUN	11	3	27.3%	0	0.0%	1	9.1%	1	9.1%	1	9.1%	2	18.2%	1	9.1%	2	18.2%	17.18
CLAY	17	0	0.0%	0	0.0%	4	23.5%	2	11.8%	1	5.9%	1	5.9%	5	29.4%	4	23.5%	23.18
DODDRIDGE	10	0	0.0%	0	0.0%	0	0.0%	1	10.0%	1	10.0%	4	40.0%	2	20.0%	2	20.0%	25.2
FAYETTE	52	2	3.8%	0	0.0%	7	13.5%	6	11.5%	3	5.8%	8	15.4%	10	19.2%	16	30.8%	22.85
GILMER	10	0	0.0%	0	0.0%	1	10.0%	0	0.0%	5	50.0%	1	10.0%	0	0.0%	3	30.0%	21.7
GRANT	13	1	7.7%	0	0.0%	2	15.4%	2	15.4%	0	0.0%	2	15.4%	2	15.4%	4	30.8%	21.62
GREENBRIER	33	0	0.0%	0	0.0%	3	9.1%	1	3.0%	3	9.1%	7	21.2%	6	18.2%	13	39.4%	26.21
HAMPSHIRE	20	0	0.0%	0	0.0%	2	10.0%	3	15.0%	3	15.0%	3	15.0%	1	5.0%	8	40.0%	24.4
HANCOCK	27	0	0.0%	0	0.0%	2	7.4%	2	7.4%	4	14.8%	3	11.1%	4	14.8%	12	44.4%	26.81
HARDY	13	0	0.0%	0	0.0%	0	0.0%	1	7.7%	1	7.7%	4	30.8%	2	15.4%	5	38.5%	26.15
HARRISON	90	5	5.6%	3	3.3%	8	8.9%	12	13.3%	10	11.1%	7	7.8%	9	10.0%	36	40.0%	23.41
JACKSON	35	1	2.9%	1	2.9%	3	8.6%	7	20.0%	4	11.4%	7	20.0%	4	11.4%	8	22.9%	21.37
JEFFERSON	53	0	0.0%	0	0.0%	9	17.0%	7	13.2%	6	11.3%	6	11.3%	10	18.9%	15	28.3%	22.64
KANAWHA	193	8	4.1%	10	5.2%	25	13.0%	23	11.9%	17	8.8%	22	11.4%	31	16.1%	57	29.5%	21.87
LEWIS	18	0	0.0%	0	0.0%	3	16.7%	1	5.6%	2	11.1%	2	11.1%	5	27.8%	5	27.8%	23.94
LINCOLN	25	0	0.0%	0	0.0%	1	4.0%	0	0.0%	7	28.0%	4	16.0%	5	20.0%	8	32.0%	26
LOGAN	45	1	2.2%	0	0.0%	6	13.3%	3	6.7%	3	6.7%	5	11.1%	7	15.6%	20	44.4%	26.69
MARION	44	0	0.0%	0	0.0%	2	4.5%	5	11.4%	7	15.9%	6	13.6%	3	6.8%	21	47.7%	26.75
MARSHALL	30	1	3.3%	0	0.0%	2	6.7%	7	23.3%	1	3.3%	4	13.3%	5	16.7%	10	33.3%	24.6
MASON	32	3	9.4%	0	0.0%	1	3.1%	3	9.4%	7	21.9%	6	18.8%	4	12.5%	8	25.0%	22.44
MCDOWELL	33	1	3.0%	0	0.0%	2	6.1%	0	0.0%	6	18.2%	7	21.2%	8	24.2%	9	27.3%	24.67
MERCER	53	0	0.0%	3	5.7%	2	3.8%	0	0.0%	3	5.7%	9	17.0%	16	30.2%	20	37.7%	27.13
MINERAL	32	0	0.0%	0	0.0%	1	3.1%	8	25.0%	2	6.3%	6	18.8%	1	3.1%	14	43.8%	26
MINGO	40	0	0.0%	1	2.5%	3	7.5%	4	10.0%	6	15.0%	10	25.0%	5	12.5%	11	27.5%	23.38
MONONGALIA	60	3	5.0%	1	1.7%	3	5.0%	6	10.0%	4	6.7%	9	15.0%	11	18.3%	23	38.3%	25.3
MONROE	13	0	0.0%	1	7.7%	0	0.0%	3	23.1%	1	7.7%	4	30.8%	0	0.0%	4	30.8%	22.69
MORGAN	21	0	0.0%	0	0.0%	4	19.0%	3	14.3%	4	19.0%	4	19.0%	3	14.3%	3	14.3%	19.86
NICHOLAS	37	1	2.7%	0	0.0%	4	10.8%	2	5.4%	1	2.7%	9	24.3%	4	10.8%	16	43.2%	25.76
OHIO	35	0	0.0%	0	0.0%	6	17.1%	3	8.6%	4	11.4%	6	17.1%	3	8.6%	13	37.1%	24.66
PENDLETON	10	0	0.0%	0	0.0%	2	20.0%	0	0.0%	2	20.0%	1	10.0%	3	30.0%	2	20.0%	22.7
PLEASANTS	12	0	0.0%	0	0.0%	0	0.0%	1	8.3%	3	25.0%	1	8.3%	3	25.0%	4	33.3%	26.08
POCAHONTAS	10	1	10.0%	0	0.0%	0	0.0%	0	0.0%	2	20.0%	1	10.0%	2	20.0%	4	40.0%	26.6
PRESTON	29	0	0.0%	0	0.0%	3	10.3%	2	6.9%	5	17.2%	3	10.3%	2	6.9%	14	48.3%	25.69
PUTNAM	67	4	6.0%	2	3.0%	1	1.5%	3	4.5%	8	11.9%	11	16.4%	14	20.9%	24	35.8%	25.18
RALEIGH	84	1	1.2%	3	3.6%	4	4.8%	6	7.1%	5	6.0%	16	19.0%	22	26.2%	27	32.1%	25.45
RANDOLPH	29	1	3.4%	0	0.0%	1	3.4%	1	3.4%	3	10.3%	2	6.9%	10	34.5%	11	37.9%	27.31
RITCHIE	12	0	0.0%	0	0.0%	2	16.7%	4	33.3%	2	16.7%	3	25.0%	0	0.0%	1	8.3%	17.42
ROANE	16	1	6.3%	0	0.0%	1	6.3%	2	12.5%	1	6.3%	5	31.3%	1	6.3%	5	31.3%	22.38
SUMMERS	10	0	0.0%	0	0.0%	2	20.0%	0	0.0%	1	10.0%	0	0.0%	3	30.0%	4	40.0%	24.6
TAYLOR	15	0	0.0%	1	6.7%	2	13.3%	1	6.7%	1	6.7%	3	20.0%	4	26.7%	3	20.0%	22.47
TUCKER	9	0	0.0%	2	22.2%	1	11.1%	0	0.0%	0	0.0%	1	11.1%	0	0.0%	5	55.6%	22.78
TYLER	11	0	0.0%	0	0.0%	3	27.3%	2	18.2%	1	9.1%	0	0.0%	3	27.3%	2	18.2%	21
UPSHUR	25	0	0.0%	1	4.0%	3	12.0%	2	8.0%	5	20.0%	3	12.0%	5	20.0%	6	24.0%	22.88
WAYNE	59	1	1.7%	2	3.4%	5	8.5%	12	20.3%	9	15.3%	10	16.9%	8	13.6%	12	20.3%	20.85
WEBSTER	13	0	0.0%	0	0.0%	3	23.1%	1	7.7%	2	15.4%	3	23.1%	1	7.7%	3	23.1%	20.85
WETZEL	19	0	0.0%	1	5.3%	1	5.3%	1	5.3%	2	10.5%	3	15.8%	5	26.3%	6	31.6%	25.37
WIRT	7	0	0.0%	0	0.0%	1	14.3%	2	28.6%	1	14.3%	0	0.0%	3	42.9%	0	0.0%	19.43
WOOD	92	0	0.0%	1	1.1%	8	8.7%	7	7.6%	12	13.0%	18	19.6%	11	12.0%	35	38.0%	25.76
WYOMING	30	0	0.0%	0	0.0%	1	3.3%	0	0.0%	2	6.7%	5	16.7%	8	26.7%	14	46.7%	29.63
Total State Personnel	1,939	45	2.3%	42	2.2%	180	9.3%	197	10.2%	219	11.3%	301	15.5%	319	16.5%	636	32.8%	23.74

TABLE A2.7
SALARY CLASSIFICATIONS OF
WEST VIRGINIA EDUCATORS
2009-2010 SCHOOL YEAR
BY COUNTY

COUNTY	Number of County Educators	Number and Percentage of Administrators Holding a:															
		Bachelors		Bachelors +15		Masters		Masters + 15		Masters + 30		Masters + 45		Doctorate		No Degree	
		N	%	N	%	N	%	N	%	N	%	N	%	N	%	N	%
BARBOUR	212	25	11.8%	53	25.0%	22	10.4%	23	10.8%	29	13.7%	56	26.4%	4	1.9%	0	0.0%
BERKELEY	1495	372	24.9%	323	21.6%	151	10.1%	141	9.4%	170	11.4%	330	22.1%	6	0.4%	2	0.1%
BOONE	447	91	20.4%	133	29.8%	28	6.3%	35	7.8%	47	10.5%	111	24.8%	1	0.2%	1	0.2%
BRAXTON	219	38	17.4%	54	24.7%	17	7.8%	18	8.2%	31	14.2%	59	26.9%	2	0.9%	0	0.0%
BROOKE	307	48	15.6%	71	23.1%	14	4.6%	23	7.5%	51	16.6%	99	32.2%	1	0.3%	0	0.0%
CABELL	1064	166	15.6%	243	22.8%	88	8.3%	110	10.3%	118	11.1%	332	31.2%	4	0.4%	3	0.3%
CALHOUN	106	32	30.2%	22	20.8%	6	5.7%	6	5.7%	10	9.4%	30	28.3%	0	0.0%	0	0.0%
CLAY	170	23	13.5%	27	15.9%	6	3.5%	13	7.6%	33	19.4%	67	39.4%	1	0.6%	0	0.0%
DODDRIDGE	119	16	13.4%	28	23.5%	10	8.4%	15	12.6%	18	15.1%	30	25.2%	2	1.7%	0	0.0%
FAYETTE	603	106	17.6%	152	25.2%	48	8.0%	50	8.3%	71	11.8%	171	28.4%	4	0.7%	1	0.2%
GILMER	88	23	26.1%	27	30.7%	11	12.5%	6	6.8%	10	11.4%	11	12.5%	0	0.0%	0	0.0%
GRANT	172	33	19.2%	41	23.8%	19	11.0%	16	9.3%	15	8.7%	45	26.2%	3	1.7%	0	0.0%
GREENBRIER	477	96	20.1%	117	24.5%	42	8.8%	33	6.9%	54	11.3%	131	27.5%	3	0.6%	1	0.2%
HAMPSHIRE	290	46	15.9%	77	26.6%	34	11.7%	34	11.7%	37	12.8%	60	20.7%	2	0.7%	0	0.0%
HANCOCK	364	41	11.3%	91	25.0%	27	7.4%	29	8.0%	36	9.9%	139	38.2%	1	0.3%	0	0.0%
HARDY	179	16	8.9%	39	21.8%	13	7.3%	25	14.0%	28	15.6%	57	31.8%	1	0.6%	0	0.0%
HARRISON	970	126	13.0%	172	17.7%	109	11.2%	95	9.8%	149	15.4%	309	31.9%	8	0.8%	2	0.2%
JACKSON	455	54	11.9%	106	23.3%	33	7.3%	63	13.8%	66	14.5%	131	28.8%	2	0.4%	0	0.0%
JEFFERSON	711	183	25.7%	175	24.6%	77	10.8%	71	10.0%	84	11.8%	113	15.9%	6	0.8%	2	0.3%
KANAWHA	2489	408	16.4%	631	25.4%	134	5.4%	222	8.9%	322	12.9%	748	30.1%	20	0.8%	4	0.2%
LEWIS	228	32	14.0%	50	21.9%	18	7.9%	24	10.5%	32	14.0%	68	29.8%	3	1.3%	1	0.4%
LINCOLN	334	55	16.5%	93	27.8%	17	5.1%	30	9.0%	29	8.7%	109	32.6%	1	0.3%	0	0.0%
LOGAN	537	121	22.5%	132	24.6%	35	6.5%	23	4.3%	41	7.6%	185	34.5%	0	0.0%	0	0.0%
MARION	707	94	13.3%	135	19.1%	86	12.2%	75	10.6%	98	13.9%	217	30.7%	2	0.3%	0	0.0%
MARSHALL	413	55	13.3%	61	14.8%	35	8.5%	47	11.4%	52	12.6%	160	38.7%	3	0.7%	0	0.0%
MASON	383	75	19.6%	85	22.2%	28	7.3%	44	11.5%	35	9.1%	113	29.5%	3	0.8%	0	0.0%
MCDOWELL	349	77	22.1%	80	22.9%	16	4.6%	16	4.6%	50	14.3%	109	31.2%	1	0.3%	0	0.0%
MERCER	835	147	17.6%	208	24.9%	48	5.7%	73	8.7%	106	12.7%	239	28.6%	8	1.0%	6	0.7%
MINERAL	396	40	10.1%	98	24.7%	26	6.6%	46	11.6%	61	15.4%	124	31.3%	1	0.3%	0	0.0%
MINGO	433	117	27.0%	84	19.4%	24	5.5%	24	5.5%	40	9.2%	141	32.6%	1	0.2%	2	0.5%
MONONGALIA	899	73	8.1%	147	16.4%	107	11.9%	109	12.1%	152	16.9%	298	33.1%	12	1.3%	1	0.1%
MONROE	177	42	23.7%	49	27.7%	12	6.8%	17	9.6%	24	13.6%	32	18.1%	1	0.6%	0	0.0%
MORGAN	232	59	25.4%	47	20.3%	43	18.5%	18	7.8%	30	12.9%	31	13.4%	3	1.3%	1	0.4%
NICHOLAS	352	56	15.9%	76	21.6%	22	6.3%	36	10.2%	41	11.6%	119	33.8%	1	0.3%	1	0.3%
OHIO	482	72	14.9%	104	21.6%	50	10.4%	53	11.0%	66	13.7%	131	27.2%	5	1.0%	1	0.2%
PENDLETON	108	17	15.7%	29	26.9%	14	13.0%	10	9.3%	7	6.5%	31	28.7%	0	0.0%	0	0.0%
PLEASANTS	132	18	13.6%	28	21.2%	9	6.8%	14	10.6%	14	10.6%	47	35.6%	2	1.5%	0	0.0%
POCAHONTAS	116	20	17.2%	35	30.2%	10	8.6%	4	3.4%	9	7.8%	35	30.2%	3	2.6%	0	0.0%
PRESTON	407	57	14.0%	95	23.3%	48	11.8%	38	9.3%	54	13.3%	106	26.0%	5	1.2%	4	1.0%
PUTNAM	792	86	10.9%	191	24.1%	55	6.9%	86	10.9%	111	14.0%	258	32.6%	4	0.5%	1	0.1%
RALEIGH	1035	150	14.5%	284	27.4%	69	6.7%	85	8.2%	117	11.3%	325	31.4%	5	0.5%	0	0.0%
RANDOLPH	386	48	12.4%	72	18.7%	23	6.0%	41	10.6%	64	16.6%	134	34.7%	4	1.0%	0	0.0%
RITCHIE	141	23	16.3%	29	20.6%	12	8.5%	9	6.4%	14	9.9%	53	37.6%	1	0.7%	0	0.0%
ROANE	210	37	17.6%	65	31.0%	11	5.2%	12	5.7%	38	18.1%	44	21.0%	3	1.4%	0	0.0%
SUMMERS	138	16	11.6%	41	29.7%	12	8.7%	11	8.0%	12	8.7%	44	31.9%	2	1.4%	0	0.0%
TAYLOR	196	15	7.7%	45	23.0%	17	8.7%	20	10.2%	26	13.3%	73	37.2%	0	0.0%	0	0.0%
TUCKER	99	15	15.2%	16	16.2%	11	11.1%	14	14.1%	12	12.1%	31	31.3%	0	0.0%	0	0.0%
TYLER	137	19	13.9%	35	25.5%	6	4.4%	16	11.7%	19	13.9%	42	30.7%	0	0.0%	0	0.0%
UPSHUR	343	44	12.8%	65	19.0%	36	10.5%	36	10.5%	58	16.9%	102	29.7%	2	0.6%	0	0.0%
WAYNE	653	126	19.3%	165	25.3%	44	6.7%	72	11.0%	89	13.6%	149	22.8%	3	0.5%	5	0.8%
WEBSTER	148	32	21.6%	47	31.8%	7	4.7%	10	6.8%	13	8.8%	39	26.4%	0	0.0%	0	0.0%
WETZEL	264	34	12.9%	66	25.0%	19	7.2%	15	5.7%	34	12.9%	95	36.0%	1	0.4%	0	0.0%
WIRT	95	26	27.4%	20	21.1%	14	14.7%	11	11.6%	9	9.5%	15	15.8%	0	0.0%	0	0.0%
WOOD	1140	185	16.2%	274	24.0%	111	9.7%	122	10.7%	134	11.8%	308	27.0%	6	0.5%	0	0.0%
WYOMING	377	72	19.1%	82	21.8%	10	2.7%	22	5.8%	57	15.1%	134	35.5%	0	0.0%	0	0.0%
Total State	24,611	4,098	16.7%	5,715	23.2%	1,994	8.1%	2,311	9.4%	3,127	12.7%	7,170	29.1%	157	0.6%	39	0.2%

TABLE A2.8
SALARY CLASSIFICATIONS OF
WEST VIRGINIA ADMINISTRATORS
2009-2010 SCHOOL YEAR
BY COUNTY

COUNTY	Number of County Administrators	Number and Percentage of Administrators Holding a:															
		Bachelors		Bachelors +15		Masters		Masters + 15		Masters + 30		Masters + 45		Doctorate		No Degree	
		N	%	N	%	N	%	N	%	N	%	N	%	N	%	N	%
BARBOUR	19	0	0.0%	2	10.5%	1	5.3%	1	5.3%	4	21.1%	10	52.6%	1	5.3%	0	0.0%
BERKELEY	102	10	9.8%	1	1.0%	6	5.9%	7	6.9%	19	18.6%	56	54.9%	2	2.0%	1	1.0%
BOONE	39	1	2.6%	1	2.6%	2	5.1%	4	10.3%	8	20.5%	22	56.4%	1	2.6%	0	0.0%
BRAXTON	19	1	5.3%	0	0.0%	2	10.5%	1	5.3%	2	10.5%	13	68.4%	0	0.0%	0	0.0%
BROOKE	22	1	4.5%	0	0.0%	0	0.0%	0	0.0%	4	18.2%	16	72.7%	1	4.5%	0	0.0%
CABELL	84	5	6.0%	1	1.2%	1	1.2%	4	4.8%	9	10.7%	62	73.8%	2	2.4%	0	0.0%
CALHOUN	11	0	0.0%	1	9.1%	2	18.2%	1	9.1%	0	0.0%	7	63.6%	0	0.0%	0	0.0%
CLAY	17	0	0.0%	0	0.0%	0	0.0%	0	0.0%	3	17.6%	14	82%	0	0.0%	0	0.0%
DODDRIDGE	10	0	0.0%	0	0.0%	0	0.0%	0	0.0%	2	20.0%	6	60.0%	2	20.0%	0	0.0%
FAYETTE	52	0	0.0%	0	0.0%	0	0.0%	4	7.7%	7	13.5%	39	75.0%	2	3.8%	0	0.0%
GILMER	10	0	0.0%	0	0.0%	1	10.0%	1	10.0%	2	20.0%	6	60.0%	0	0.0%	0	0.0%
GRANT	13	2	15.4%	0	0.0%	0	0.0%	2	15.4%	0	0.0%	8	61.5%	1	7.7%	0	0.0%
GREENBRIER	33	0	0.0%	1	3.0%	1	3.0%	1	3.0%	7	21.2%	22	66.7%	1	3.0%	0	0.0%
HAMPSHIRE	20	0	0.0%	0	0.0%	0	0.0%	3	15.0%	4	20.0%	12	60.0%	1	5.0%	0	0.0%
HANCOCK	27	2	7.4%	1	3.7%	1	3.7%	0	0.0%	1	3.7%	22	81.5%	0	0.0%	0	0.0%
HARDY	13	1	7.7%	2	15.4%	0	0.0%	1	7.7%	0	0.0%	9	69.2%	0	0.0%	0	0.0%
HARRISON	90	2	2.2%	3	3.3%	5	5.6%	7	7.8%	14	15.6%	55	61.1%	3	3.3%	1	1.1%
JACKSON	35	0	0.0%	1	2.9%	2	5.7%	4	11.4%	11	31.4%	17	48.6%	0	0.0%	0	0.0%
JEFFERSON	53	5	9.4%	1	1.9%	6	11.3%	4	7.5%	13	24.5%	20	37.7%	4	7.5%	0	0.0%
KANAWHA	193	4	2.1%	3	1.6%	16	8.3%	10	5.2%	40	20.7%	109	56.5%	11	5.7%	0	0.0%
LEWIS	18	0	0.0%	1	5.6%	0	0.0%	2	11.1%	2	11.1%	11	61.1%	2	11.1%	0	0.0%
LINCOLN	25	1	4.0%	0	0.0%	0	0.0%	2	8.0%	4	16.0%	18	72.0%	0	0.0%	0	0.0%
LOGAN	45	0	0.0%	1	2.2%	1	2.2%	1	2.2%	6	13.3%	35	77.8%	1	2.2%	0	0.0%
MARION	44	0	0.0%	1	2.3%	2	4.5%	2	4.5%	12	27.3%	27	61.4%	0	0.0%	0	0.0%
MARSHALL	30	2	6.7%	0	0.0%	1	3.3%	2	6.7%	2	6.7%	21	70.0%	2	6.7%	0	0.0%
MASON	32	0	0.0%	0	0.0%	3	9.4%	3	9.4%	7	21.9%	16	50.0%	3	9.4%	0	0.0%
MCDOWELL	33	1	3.0%	0	0.0%	0	0.0%	0	0.0%	3	9.1%	28	84.8%	1	3.0%	0	0.0%
MERCER	53	1	1.9%	1	1.9%	1	1.9%	3	5.7%	7	13.2%	36	67.9%	4	7.5%	0	0.0%
MINERAL	32	2	6.3%	1	3.1%	0	0.0%	2	6.3%	4	12.5%	22	68.8%	1	3.1%	0	0.0%
MINGO	40	0	0.0%	0	0.0%	2	5.0%	1	2.5%	5	12.5%	32	80.0%	0	0.0%	0	0.0%
MONONGALIA	60	4	6.7%	1	1.7%	4	6.7%	1	1.7%	9	15.0%	39	65.0%	2	3.3%	0	0.0%
MONROE	13	1	7.7%	1	7.7%	1	7.7%	3	23.1%	3	23.1%	3	23.1%	1	7.7%	0	0.0%
MORGAN	21	0	0.0%	0	0.0%	4	19.0%	0	0.0%	8	38.1%	8	38.1%	1	4.8%	0	0.0%
NICHOLAS	37	2	5.4%	0	0.0%	4	10.8%	1	2.7%	2	5.4%	27	73.0%	1	2.7%	0	0.0%
OHIO	35	0	0.0%	0	0.0%	2	5.7%	1	2.9%	6	17.1%	24	68.6%	2	5.7%	0	0.0%
PENDLETON	10	0	0.0%	0	0.0%	3	30.0%	1	10.0%	0	0.0%	6	60.0%	0	0.0%	0	0.0%
PLEASANTS	12	0	0.0%	0	0.0%	0	0.0%	0	0.0%	0	0.0%	10	83.3%	2	16.7%	0	0.0%
POCAHONTAS	10	0	0.0%	0	0.0%	2	20.0%	1	10.0%	2	20.0%	4	40.0%	1	10.0%	0	0.0%
PRESTON	29	0	0.0%	1	3.4%	0	0.0%	1	3.4%	5	17.2%	19	65.5%	3	10.3%	0	0.0%
PUTNAM	67	4	6.0%	2	3.0%	1	1.5%	3	4.5%	7	10.4%	47	70.1%	3	4.5%	0	0.0%
RALEIGH	84	3	3.6%	2	2.4%	5	6.0%	3	3.6%	16	19.0%	52	61.9%	3	3.6%	0	0.0%
RANDOLPH	29	1	3.4%	0	0.0%	1	3.4%	2	6.9%	6	20.7%	18	62.1%	1	3.4%	0	0.0%
RITCHIE	12	0	0.0%	0	0.0%	0	0.0%	1	8.3%	4	33.3%	7	58.3%	0	0.0%	0	0.0%
ROANE	16	0	0.0%	0	0.0%	1	6.3%	1	6.3%	2	12.5%	11	68.8%	1	6.3%	0	0.0%
SUMMERS	10	0	0.0%	0	0.0%	1	10.0%	1	10.0%	0	0.0%	7	70.0%	1	10.0%	0	0.0%
TAYLOR	15	0	0.0%	0	0.0%	1	6.7%	2	13.3%	2	13.3%	10	66.7%	0	0.0%	0	0.0%
TUCKER	9	0	0.0%	0	0.0%	1	11.1%	0	0.0%	1	11.1%	7	77.8%	0	0.0%	0	0.0%
TYLER	11	0	0.0%	1	9.1%	0	0.0%	0	0.0%	1	9.1%	9	81.8%	0	0.0%	0	0.0%
UPSHUR	25	1	4.0%	1	4.0%	0	0.0%	0	0.0%	8	32.0%	14	56.0%	1	4.0%	0	0.0%
WAYNE	59	1	1.7%	0	0.0%	4	6.8%	1	1.7%	11	18.6%	39	66.1%	3	5.1%	0	0.0%
WEBSTER	13	0	0.0%	0	0.0%	0	0.0%	0	0.0%	3	23.1%	10	76.9%	0	0.0%	0	0.0%
WETZEL	19	0	0.0%	0	0.0%	1	5.3%	1	5.3%	1	5.3%	16	84.2%	0	0.0%	0	0.0%
WIRT	7	0	0.0%	0	0.0%	0	0.0%	0	0.0%	2	28.6%	5	71.4%	0	0.0%	0	0.0%
WOOD	92	6	6.5%	1	1.1%	3	3.3%	13	14.1%	12	13.0%	53	57.6%	4	4.3%	0	0.0%
WYOMING	30	2	6.7%	1	3.3%	0	0.0%	0	0.0%	3	10.0%	24	80.0%	0	0.0%	0	0.0%
Total State	1,939	66	3.4%	34	1.8%	95	4.9%	110	5.7%	316	16.3%	1,240	64.0%	76	3.9%	2	0.1%

TABLE A2.9

EXPERIENCE AND SALARY CLASSIFICATIONS OF
WEST VIRGINIA EDUCATORS
2009-2010 SCHOOL YEAR

EXPERIENCE	NUMBER OF PERSONNEL	Number and Percentage of Educators Holding a:															
		Less than a Bachelors		Bachelors		Bachelors +15		Masters		Masters + 15		Masters + 30		Masters + 45		Doctorate	
		N	%	N	%	N	%	N	%	N	%	N	%	N	%	N	%
0-3 Years	3892	9	0.23%	2260	58%	487	13%	579	15%	235	6%	200	5%	115	3%	7	0.18%
4-5 Years	1847	3	0.16%	632	34%	417	23%	289	16%	202	11%	175	9%	124	7%	5	0.27%
6-10 Years	3458	11	0.32%	672	19%	926	27%	423	12%	512	15%	420	12%	481	14%	13	0.38%
11-15 Years	2809	8	0.28%	219	8%	793	28%	219	8%	413	15%	511	18%	637	23%	9	0.32%
16-20 Years	2400	4	0.17%	118	5%	666	28%	122	5%	260	11%	401	17%	808	34%	21	0.88%
21-25 Years	3026	0	0.00%	88	3%	843	28%	112	4%	274	9%	439	15%	1248	41%	22	0.73%
26-30 Years	3161	1	0.03%	49	2%	789	25%	121	4%	204	6%	451	14%	1517	48%	29	0.92%
Above 30 Years	4019	3	0.07%	61	2%	794	20%	129	3%	211	5%	530	13%	2240	56%	51	1.27%
Total	24612	39	0.16%	4099	17%	5715	23%	1994	8%	2311	9%	3127	13%	7170	29%	157	0.64%

EXPERIENCE AND SALARY CLASSIFICATIONS OF
WEST VIRGINIA ADMINISTRATORS
2008-2009 SCHOOL YEAR

EXPERIENCE	NUMBER OF PERSONNEL	Number and Percentage of Administrators Holding a:															
		Less than a Bachelors		Bachelors		Bachelors +15		Masters		Masters + 15		Masters + 30		Masters + 45		Doctorate	
		N	%	N	%	N	%	N	%	N	%	N	%	N	%	N	%
0-3 Years	45	0	0.00%	12	27%	3	7%	12	27%	4	9%	8	18%	4	9%	2	4%
4-5 Years	42	0	0.00%	9	21%	3	7%	8	19%	9	21%	7	17%	5	12%	1	2%
6-10 Years	180	0	0.00%	18	10%	4	2%	29	16%	25	14%	33	18%	65	36%	6	3%
11-15 Years	197	1	0.51%	11	6%	0	0%	15	8%	19	10%	49	25%	101	51%	1	1%
16-20 Years	219	0	0.00%	3	1%	2	1%	17	8%	11	5%	55	25%	126	58%	5	2%
21-25 Years	301	1	0.33%	5	2%	7	2%	6	2%	11	4%	54	18%	208	69%	9	3%
26-30 Years	319	0	0.00%	6	2%	6	2%	2	1%	14	4%	34	11%	239	75%	18	6%
Above 30 Years	636	0	0.00%	2	0%	9	1%	6	1%	17	3%	76	12%	492	77%	34	5%
Total	1939	2	0.10%	66	3%	34	2%	95	5%	110	6%	316	16%	1240	64%	76	4%

TABLE A2.10
AVERAGE SALARIES FOR PUBLIC SCHOOL EDUCATORS
BY COUNTY

COUNTY	2008-2009		2009-2010	
	FTE	AVERAGE SALARY	FTE	AVERAGE SALARY
BARBOUR	213.5	\$45,235.55	210	\$45,517.54
BERKELEY	1,451	\$47,296.10	1479.55	\$47,324.02
BOONE	444	\$47,608.64	452.5	\$47,568.32
BRAXTON	219.5	\$46,290.44	220.5	\$46,179.73
BROOKE	302.5	\$47,676.80	307.5	\$47,374.60
CABELL	1,068	\$46,820.64	1074.45	\$47,120.93
CALHOUN	107.5	\$44,309.64	105.5	\$44,309.91
CLAY	171	\$46,144.35	171.5	\$46,105.34
DODDRIDGE	117.5	\$45,564.13	120.5	\$45,882.24
FAYETTE	607	\$47,229.78	609	\$47,054.62
GILMER	88.6	\$45,661.22	88.5	\$44,318.35
GRANT	179.5	\$44,327.64	171.5	\$44,062.54
GREENBRIER	465.6	\$46,634.64	477.6	\$46,133.29
HAMPSHIRE	298.73	\$44,067.14	295.75	\$43,958.69
HANCOCK	366	\$48,055.23	370	\$48,700.47
HARDY	176.5	\$45,947.54	179.5	\$45,680.39
HARRISON	948.1108	\$47,692.67	938.745	\$47,919.59
JACKSON	440.5	\$48,413.63	452.5	\$48,227.22
JEFFERSON	707.7801	\$45,064.17	723	\$45,691.31
KANAWHA	2,462	\$48,077.90	2,499	\$47,878.60
LEWIS	236.5	\$46,732.40	231.5	\$46,639.58
LINCOLN	321	\$45,423.09	336.5	\$45,799.88
LOGAN	532	\$46,201.73	541	\$45,957.14
MARION	704.2	\$46,690.68	704.2	\$46,414.79
MARSHALL	418	\$49,992.65	416	\$49,892.66
MASON	387	\$46,334.91	382	\$46,145.89
MERCER	351	\$47,071.71	830	\$45,713.45
MINERAL	829	\$46,111.96	392.5	\$48,077.82
MINGO	393.5	\$48,211.57	438.334	\$46,206.34
MONONGALIA	420.5006	\$46,813.81	921.8	\$46,834.25
MONROE	905.8	\$46,988.66	178.8574	\$43,129.69
MORGAN	177.9674	\$43,116.54	230.75	\$45,380.51
MCDOWELL	231.25	\$44,695.60	354	\$47,483.50
NICHOLAS	370	\$45,938.94	356.25	\$46,054.54
OHIO	459.67	\$48,909.00	459.25	\$48,457.92
PENDLETON	101.4251	\$46,811.91	106.315	\$46,051.45
PLEASANTS	131	\$51,104.96	131.5	\$49,446.36
POCAHONTAS	112.5	\$44,926.51	114.5	\$44,836.89
PRESTON	412.55	\$44,840.64	413.21	\$44,974.43
PUTNAM	774	\$49,771.58	795	\$49,824.11
RALEIGH	1,033	\$46,281.59	1028.8	\$46,557.51
RANDOLPH	382.9	\$47,339.69	390	\$46,925.35
RITCHIE	145	\$47,251.79	143	\$46,644.74
ROANE	211.5001	\$45,260.40	213	\$44,431.06
SUMMERS	140	\$45,713.77	140	\$45,885.50
TAYLOR	191.5	\$47,632.19	195	\$47,046.36
TUCKER	101	\$45,627.75	102	\$45,648.89
TYLER	140	\$46,755.80	139	\$46,819.64
UPSHUR	335.8	\$46,476.18	344.8	\$46,310.53
WAYNE	651.5	\$44,587.43	665.1	\$44,135.75
WEBSTER	141.5	\$45,142.71	149	\$43,614.86
WETZEL	256.745	\$49,764.49	259	\$49,217.55
WIRT	93	\$42,535.11	95	\$43,085.25
WOOD	1,116	\$48,678.89	1125.875	\$48,405.23
WYOMING	381.75	\$46,941.34	379	\$47,003.46
STATE AVERAGES	24,424	\$46,559.92	24,649	\$46,401.10

NOTE: Column totals, where applicable, may not add up to 100% due to rounding.

FTE: Full Time Equivalency

**TABLE A2.11
AVERAGE SALARIES FOR CLASSROOM TEACHERS
BY COUNTY**

COUNTY	2008-2009		2009-2010	
	FTE	AVERAGE SALARY	FTE	AVERAGE SALARY
BARBOUR	180.6	\$43,877.38	174.0	\$44,006.66
BERKELEY	1,208.0	\$44,475.50	1,230.0	\$44,359.98
BOONE	369.5	\$45,157.31	378.0	\$45,155.33
BRAXTON	180.5	\$43,865.15	180.5	\$43,947.60
BROOKE	248.8	\$45,572.07	250.8	\$45,086.77
CABELL	852.0	\$44,553.14	855.0	\$44,914.40
CALHOUN	87.5	\$41,476.87	86.0	\$41,719.01
CLAY	148.2	\$43,902.25	146.5	\$43,696.93
DODDRIDGE	88.0	\$43,822.63	90.0	\$43,612.50
FAYETTE	504.5	\$45,160.40	508.4	\$44,949.04
GILMER	65.1	\$43,438.91	66.5	\$42,272.11
GRANT	142.5	\$42,384.43	139.3	\$41,981.07
GREENBRIER	373.1	\$44,259.82	380.1	\$43,780.86
HAMPSHIRE	244.7	\$41,647.05	236.8	\$41,249.61
HANCOCK	293.0	\$45,263.88	293.0	\$45,667.88
HARDY	143.5	\$43,882.76	145.0	\$43,589.13
HARRISON	741.1	\$45,203.20	729.6	\$45,438.47
JACKSON	352.3	\$46,177.92	353.3	\$45,979.55
JEFFERSON	596.3	\$42,425.30	601.5	\$42,820.50
KANAWHA	1,959.0	\$45,802.69	1,988.0	\$45,592.10
LEWIS	183.5	\$44,544.05	179.0	\$44,326.30
LINCOLN	265.0	\$43,279.99	269.5	\$43,810.17
LOGAN	438.0	\$44,040.15	447.0	\$43,629.61
MARION	597.7	\$44,771.06	586.7	\$44,349.57
MARSHALL	334.5	\$48,050.63	330.5	\$47,784.43
MASON	327.0	\$44,407.85	319.0	\$44,019.34
MERCER	264.5	\$44,307.41	645.0	\$43,712.88
MINERAL	676.0	\$44,195.59	319.3	\$45,237.17
MINGO	321.3	\$45,657.73	334.1	\$43,109.90
MONONGALIA	324.0	\$44,017.54	711.5	\$44,161.31
MONROE	704.0	\$44,466.57	148.5	\$41,133.96
MORGAN	149.0	\$41,615.15	180.0	\$42,436.57
MCDOWELL	179.2	\$41,872.95	264.0	\$44,672.28
NICHOLAS	313.0	\$44,050.16	298.3	\$44,091.06
OHIO	357.5	\$46,420.85	359.3	\$45,940.31
PENDLETON	86.4	\$44,812.49	89.6	\$43,715.18
PLEASANTS	105.5	\$48,032.42	105.0	\$45,837.29
POCAHONTAS	88.5	\$42,533.01	89.8	\$42,517.26
PRESTON	337.8	\$43,600.34	336.8	\$43,355.66
PUTNAM	637.5	\$47,419.84	656.0	\$47,281.71
RALEIGH	812.5	\$43,704.47	810.5	\$43,827.92
RANDOLPH	321.0	\$45,345.62	327.5	\$44,702.88
RITCHIE	112.5	\$45,206.80	111.5	\$44,314.63
ROANE	179.0	\$43,388.21	177.0	\$43,053.37
SUMMERS	104.0	\$42,880.16	104.5	\$43,426.13
TAYLOR	154.5	\$46,014.89	154.0	\$45,563.16
TUCKER	81.0	\$43,309.08	82.6	\$43,255.57
TYLER	109.0	\$44,643.43	111.0	\$44,355.98
UPSHUR	280.3	\$44,712.69	284.3	\$44,393.67
WAYNE	529.3	\$42,338.90	543.5	\$41,774.95
WEBSTER	110.0	\$43,561.11	124.0	\$42,453.64
WETZEL	211.5	\$47,420.90	216.0	\$46,522.68
WIRT	77.0	\$39,823.83	77.0	\$40,216.20
WOOD	923.0	\$46,256.31	917.0	\$45,820.75
WYOMING	325.3	\$44,495.80	324.5	\$44,525.52
STATE AVERAGES	19,798	\$44,319.03	19,865.7	\$44,057.25

NOTE: Column totals, where applicable, may not add up to 100% due to rounding.
FTE: Full Time Equivalency

TABLE A2.12
AVERAGE SALARIES FOR BEGINNING CLASSROOM TEACHERS
BY COUNTY

COUNTY	2008-2009	2009-2010
	AVERAGE SALARY	AVERAGE SALARY
BARBOUR	\$30,187.00	\$30,187.00
BERKELEY	\$33,000.00	\$33,000.00
BOONE	\$33,277.00	\$33,277.00
BRAXTON	\$30,187.00	\$30,187.00
BROOKE	\$30,513.00	\$30,513.00
CABELL	\$31,337.00	\$31,337.00
CALHOUN	\$30,687.00	\$30,687.00
CLAY	\$30,187.00	\$30,187.00
DODDRIDGE	\$30,187.00	\$30,187.00
FAYETTE	\$31,087.00	\$31,387.00
GILMER	\$30,187.00	\$30,187.00
GRANT	\$30,187.00	\$30,187.00
GREENBRIER	\$30,687.00	\$30,687.00
HAMPSHIRE	\$30,187.00	\$30,187.00
HANCOCK	\$31,785.00	\$31,785.00
HARDY	\$30,187.00	\$30,187.00
HARRISON	\$31,127.00	\$31,127.00
JACKSON	\$32,397.00	\$32,397.00
JEFFERSON	\$31,772.00	\$31,772.00
KANAWHA	\$31,918.00	\$31,918.00
LEWIS	\$30,187.00	\$30,187.00
LINCOLN	\$30,487.00	\$30,937.00
LOGAN	\$31,187.00	\$31,187.00
MARION	\$30,227.00	\$30,227.00
MARSHALL	\$31,452.00	\$31,452.00
MASON	\$31,312.00	\$31,312.00
MERCER	\$30,287.00	\$30,287.00
MINERAL	\$30,862.00	\$30,862.00
MINGO	\$30,687.00	\$30,687.00
MONONGALIA	\$31,412.00	\$31,412.00
MONROE	\$30,187.00	\$30,187.00
MORGAN	\$32,343.00	\$32,343.00
MCDOWELL	\$30,387.00	\$31,337.00
NICHOLAS	\$30,187.00	\$30,187.00
OHIO	\$31,387.00	\$31,387.00
PENDLETON	\$30,187.00	\$30,187.00
PLEASANTS	\$31,879.00	\$31,879.00
POCAHONTAS	\$30,187.00	\$30,187.00
PRESTON	\$30,187.00	\$30,187.00
PUTNAM	\$32,814.00	\$32,814.00
RALEIGH	\$30,937.00	\$31,237.00
RANDOLPH	\$30,187.00	\$30,187.00
RITCHIE	\$30,537.00	\$30,887.00
ROANE	\$30,187.00	\$30,187.00
SUMMERS	\$30,187.00	\$30,187.00
TAYLOR	\$30,437.00	\$30,437.00
TUCKER	\$30,187.00	\$30,187.00
TYLER	\$30,187.00	\$30,187.00
UPSHUR	\$30,187.00	\$30,187.00
WAYNE	\$30,187.00	\$30,187.00
WEBSTER	\$30,187.00	\$30,187.00
WETZEL	\$30,187.00	\$30,187.00
WIRT	\$30,187.00	\$30,187.00
WOOD	\$31,947.00	\$31,947.00
WYOMING	\$30,187.00	\$30,187.00
STATE AVERAGES	\$30,815.00	\$30,858.00

NOTE: Column totals, where applicable, may not add up to 100% due to rounding.

FTE: Full Time Equivalency

TABLE A2.13
WEST VIRGINIA EDUCATORS
HOLDING PERMANENT LICENSES
2009-2010 SCHOOL YEAR
BY COUNTY

COUNTY	PROFESSIONAL EMPLOYEES		PERMANENT LICENSE		PERCENT OF EMPLOYEES WITH PERMANENT LICENSE	
	2008-2009	2009-2010	2008-2009	2009-2010	2008-2009	2009-2010
BARBOUR	216	212	139	137	64%	65%
BERKELEY	1452	1495	590	623	41%	42%
BOONE	437	447	258	266	59%	60%
BRAXTON	217	219	138	134	64%	61%
BROOKE	303	307	196	187	65%	61%
CABELL	1059	1064	627	618	59%	58%
CALHOUN	107	106	58	54	54%	51%
CLAY	170	170	114	113	67%	66%
DODDRIDGE	117	119	64	65	55%	55%
FAYETTE	599	603	386	368	64%	61%
GILMER	87	88	58	54	67%	61%
GRANT	180	172	89	85	49%	49%
GREENBRIER	464	477	276	264	59%	55%
HAMPSHIRE	293	290	152	160	52%	55%
HANCOCK	362	364	208	204	57%	56%
HARDY	177	179	115	118	65%	66%
HARRISON	977	970	595	588	61%	61%
JACKSON	444	455	275	273	62%	60%
JEFFERSON	697	711	293	305	42%	43%
KANAWHA	2453	2490	1485	1467	61%	59%
LEWIS	233	228	153	148	66%	65%
LINCOLN	318	334	182	184	57%	55%
LOGAN	529	537	317	302	60%	56%
MARION	707	707	463	439	65%	62%
MARSHALL	419	413	275	262	66%	63%
MASON	386	383	225	211	58%	55%
MCDOWELL	348	349	236	227	68%	65%
MERCER	831	835	502	480	60%	57%
MINERAL	393	396	242	238	62%	60%
MINGO	413	433	252	233	61%	54%
MONONGALIA	875	899	530	532	61%	59%
MONROE	177	177	87	87	49%	49%
MORGAN	228	232	89	92	39%	40%
NICHOLAS	365	352	235	224	64%	64%
OHIO	484	482	274	267	57%	55%
PENDLETON	102	108	66	63	65%	58%
PLEASANTS	132	132	91	78	69%	59%
POCAHONTAS	113	116	60	61	53%	53%
PRESTON	408	407	259	249	63%	61%
PUTNAM	774	792	474	479	61%	60%
RALEIGH	1040	1035	606	602	58%	58%
RANDOLPH	381	386	259	253	68%	66%
RITCHIE	143	141	97	88	68%	62%
ROANE	207	210	135	126	65%	60%
SUMMERS	139	138	81	82	58%	59%
TAYLOR	193	196	132	128	68%	65%
TUCKER	102	99	59	55	58%	56%
TYLER	138	137	86	83	62%	61%
UPSHUR	334	343	219	221	66%	64%
WAYNE	638	653	360	354	56%	54%
WEBSTER	140	148	93	86	66%	58%
WETZEL	264	264	175	169	66%	64%
WIRT	93	95	41	43	44%	45%
WOOD	1131	1140	720	692	64%	61%
WYOMING	379	377	247	241	65%	64%
Total State Personnel	24,368	24,612	14,438	14,162	59%	58%

TABLE B1
WEST VIRGINIA FULL-TIME EQUIVALENCY
PROFESSIONAL POSTED POSITIONS BY SPECIALIZATION
2009 - 2010 SCHOOL YEAR

PROFESSIONAL SPECIALIZATIONS	2008 - 2009 STATUS OF PERSONNEL WHO FILLED 2009 - 2010 POSTED POSITIONS								POSTED POSITIONS FILLED BY 1ST YEAR EDUCATORS WHOSE BACHELOR'S DEGREE WAS	
	2009 - 2010 TOTAL POSITIONS POSTED	2009 - 2010 POSTED POSITIONS FILLED	2009 - 2010 POSITIONS NOT FILLED	EMPLOYED IN REPORTING COUNTY SCHOOL SYSTEM	EMPLOYED IN ANOTHER WV COUNTY SCHOOL SYSTEM	EMPLOYED IN OUT-OF-STATE SCHOOL SYSTEM	EMPLOYED IN HIGHER EDUCATION	NOT EMPLOYED IN EDUCATION	COMPLETED AT A WV INSTITUTION	COMPLETED AT AN OUT-OF-STATE INSTITUTION
	(1)	(2)	(3)	(4)	(5)	(6)	(7)	(8)	(9)	(10)
GENERAL EDUCATION	25.5	21.5	4	13.5	2.0	2.0	0.0	1.5	2.5	0.0
ALTERNATIVE EDUCATION	48	44.5	3.5	23.0	1.0	3.0	0.0	1.5	13.5	2.5
ART	40.5	35	5.5	20.0	3.0	3.0	0.0	0.5	8.5	0.0
BIOLOGY	20	19	1	3.0	5.5	1.0	0.0	3.5	4.5	1.5
CHEMISTRY	1	1	0	0.0	0.0	1.0	0.0	0.0	0.0	0.0
CHINESE	0	0	0	0.0	0.0	0.0	0.0	0.0	0.0	0.0
DANCE	15.5	15	0.5	12.0	1.5	0.0	0.0	1.0	0.5	0.0
DRIVER EDUCATION/SAFETY EDUCATION	186	159	7	110.0	9.0	9.0	0.0	3.0	24.0	4.0
EARLY CHILDHOOD K-4	54	54	0	40.5	1.0	1.0	0.0	4.0	5.5	2.0
ELEMENTARY EDUCATION	924	913.5	10.5	716.0	32.0	12.5	0.0	26.5	101.5	25.0
ENGLISH AS A SECOND LANGUAGE	6.5	4.5	2	1.5	0.0	1.5	0.0	0.0	1.5	0.0
ENGLISH LANGUAGE ARTS	202.5	184.5	18	84.5	28.0	14.0	0.0	7.5	44.5	6.0
FRENCH	9.5	7.5	2	4.0	2.0	4.0	0.0	0.5	1.0	0.0
GENERAL SCIENCE	87	79	8	40.0	5.5	8.0	0.0	6.0	16.5	3.0
GERMAN	0.5	0.5	0	0.5	0.0	0.0	0.0	0.0	0.0	0.0
HEALTH	43.5	40	3.5	25.0	3.0	2.5	0.0	1.0	7.0	1.5
JAPANESE	0	0	0	0.0	0.0	0.0	0.0	0.0	0.0	0.0
JOURNALISM	2.5	2.5	0	0.0	1.0	1.0	0.0	0.0	0.5	0.0
LATIN	0.5	0	0.5	0.0	0.0	0.0	0.0	0.0	0.0	0.0
MATHEMATICS	173.5	149.5	24	54.0	16.0	17.0	1.0	12.0	32.5	17.0
MUSIC	77	75	2	31.5	7.5	5.0	0.0	7.0	20.5	3.5
ORAL COMMUNICATIONS	1	1	0	1.0	0.0	1.0	0.0	0.0	0.0	0.0
PHYSICAL EDUCATION	74	69.5	4.5	45.5	3.0	1.0	0.0	2.0	16.0	2.0
PHYSICS	8.5	6.5	2	2.5	0.5	0.0	0.0	1.0	2.0	0.5
PRESCHOOL EDUCATION	45	42.5	2.5	27.5	6.0	0.0	0.0	5.0	3.0	1.0
READING	67	53	4	40.5	2.0	1.0	0.0	3.0	6.5	0.0
READING SPECIALIST	155.5	135.5	20	77.0	11.5	6.5	0.0	1.5	36.5	2.5
RUSSIAN	0	0	0	0.0	0.0	0.0	0.0	0.0	0.0	0.0
SAFETY EDUCATION	5	5	0	4.0	1.0	0.0	0.0	0.0	0.0	0.0
SCHOOL LIBRARY/MEDIA	36	33	3	14.0	7.0	4.5	0.0	0.5	6.0	1.0
SOCIAL STUDIES	132	127.5	4.5	73.5	11.5	14.0	0.0	4.0	17.5	7.0
SPANISH	34.5	25.5	9	7.5	7.5	0.5	0.0	2.5	3.5	4.0
THEATER	2	2	0	0.0	2.0	0.0	0.0	0.0	0.0	0.0
WELLNESS	0	0	0	0.0	0.0	0.0	0.0	0.0	0.0	0.0
GENERAL EDUCATION TOTALS	2448	2306.5	141.5	1472	170	109	1	95	375.5	84
SPECIAL EDUCATION										
AMERICAN SIGN LANGUAGE	0	0	0	0.0	0.0	0.0	0.0	0.0	0.0	0.0
AUTISM	100	80	20	37.0	4.5	1.0	0.0	0.5	35.0	2.0
BEHAVIOR DISORDERS	55.5	39.5	16	25.5	6.0	0.0	0.0	0.0	7.0	1.0
GIFTED	33.5	27	6.5	15.0	2.5	1.0	1.0	1.0	6.5	0.0
HEARING IMPAIRED	9	8	1	3.0	1.0	1.0	0.0	0.0	1.0	2.0
MENTALLY IMPAIRED	47	38	9	22.0	3.5	1.0	0.0	1.5	10.0	0.0
MULTI-CATEGORICAL	302.5	257.5	45	122.5	21.5	22.0	0.0	10.5	72.0	9.0
PRESCHOOL SPECIAL NEEDS	64	54.5	9.5	24.0	8.0	3.0	0.0	5.5	13.0	1.0
SEVERELY/PROFOUNDLY IMPAIRED	13	9.5	3.5	3.5	2.0	1.0	0.0	0.0	2.0	1.0
SPECIFIC LEARNING DISABILITIES	52.5	45.5	7	28.5	7.0	2.0	0.0	1.5	7.5	1.0
VISUALLY IMPAIRED	11	9.5	1.5	2.0	2.0	0.0	0.0	3.0	2.5	0.0
SPECIAL EDUCATION TOTALS	688	569	119	281	58	32	1	23.5	156.5	17
ADMINISTRATIVE/SUPPORT										
ATHLETIC TRAINER	24	18	6	6.0	1.0	0.0	0.0	10.0	1.0	0.0
COUNSELOR	90	84	6	41.5	16.0	6.0	1.0	1.5	18.0	0.0
EDUCATIONAL AUDIOLOGIST	0	0	0	0.0	0.0	0.0	0.0	0.0	0.0	0.0
PRINCIPAL	158	157.5	0.5	121.5	21.0	12.0	0.0	3.0	0.0	0.0
SCHOOL BUSINESS OFFICIAL	13	13	0	2.0	4.0	0.0	0.0	7.0	0.0	0.0
SCHOOL NURSE	27	25	2	10.0	0.0	0.0	0.0	11.0	4.0	0.0
SCHOOL PSYCHOLOGIST	15	15	0	3.0	4.0	1.0	0.0	4.0	3.0	0.0
SOCIAL SERVICE AND ATTENDANCE	13	13	0	5.5	4.0	0.0	0.0	3.5	0.0	0.0
SPEECH LANGUAGE PATHOLOGIST	61	35	26	9.0	6.0	2.0	1.0	9.0	8.0	0.0
SUPERINTENDENT	12	11	1	6.0	5.0	0.0	0.0	0.0	0.0	0.0
SUPERVISOR OF INSTRUCTION	32	29	3	28.0	2.0	0.0	0.0	0.0	1.0	0.0
VOCATIONAL ADMINISTRATION	6.5	5.5	1	4.5	1.0	0.0	0.0	0.0	0.0	0.0
ADMINISTRATIVE/SUPPORT TOTALS	451.5	406	45.5	235	64	21	2	49	35	0
CAREER EDUCATION										
AGRICULTURE	6.5	6.5	0	2.5	1.0	0.0	0.0	1.0	1.0	1.0
BUSINESS EDUCATION	36.5	33.5	3	12.5	6.0	1.0	1.0	5.0	7.0	1.0
COMPUTER SCIENCE	5.5	5.5	0	5.0	0.0	0.0	0.0	0.0	0.5	0.0
FAMILY AND CONSUMER SCIENCE	19	15.5	3.5	5.5	2.0	1.0	0.0	4.0	2.0	1.0
MARKETING	0.5	0.5	0	0.5	0.0	0.0	0.0	0.0	0.0	0.0
TECHNOLOGY EDUCATION	45	43	2	32.0	2.0	1.0	2.0	2.0	4.0	0.0
CAREER EDUCATION TOTALS	113	104.5	8.5	58	11	3	3	12	14.5	3
OTHER SPECIALIZATIONS										
OTHER	100	94	6	63.5	9.0	2.0	0.0	16.5	2.0	1.0
TOTALS	3800.5	3480	320.5	2109.5	312	167	7	196	583.5	105

TABLE B2
WEST VIRGINIA FULL-TIME EQUIVALENCY
PROFESSIONAL POSTED POSITIONS NOT FILLED AND REASONS
2009 - 2010 SCHOOL YEAR

PROFESSIONAL SPECIALIZATIONS	2009 - 2010 TOTAL POSITIONS POSTED	2009 - 2010 POSITIONS NOT FILLED	PROFESSIONAL POSITIONS NOT FILLED BY FULL-TIME EMPLOYEE DUE TO			
			LACK OF QUALIFIED APPLICANTS	CURRENT FISCAL RESTRAINTS	CANDIDATE SELECTION IN PROGRESS	OTHER
	(1)	(2)	(3)	(4)	(5)	(6)
GENERAL EDUCATION						
ALTERNATIVE EDUCATION	25.5	4	4.0	0.0	0.0	0.0
ART	48	3.5	2.5	0.0	1.0	0.0
BIOLOGY	40.5	5.5	3.5	0.0	1.0	1.0
CHEMISTRY	20	1	1.0	0.0	0.0	0.0
CHINESE	1	0	0.0	0.0	0.0	0.0
DANCE	0	0	0.0	0.0	0.0	0.0
DRIVER EDUCATION/SAFETY EDUCATION	15.5	0.5	0.5	0.0	0.0	0.0
EARLY CHILDHOOD K-4	166	7	1.0	3.0	3.0	0.0
EARLY EDUCATION	54	0	0.0	0.0	0.0	0.0
ELEMENTARY EDUCATION	924	10.5	6.5	0.0	3.0	1.0
ENGLISH AS A SECOND LANGUAGE	6.5	2	2.0	0.0	0.0	0.0
ENGLISH LANGUAGE ARTS	202.5	18	11.5	0.0	5.5	1.0
FRENCH	9.5	2	2.0	0.0	0.0	0.0
GENERAL SCIENCE	87	8	5.0	0.0	3.0	0.0
GERMAN	0.5	0	0.0	0.0	0.0	0.0
HEALTH	43.5	3.5	2.5	0.0	1.0	0.0
JAPANESE	0	0	0.0	0.0	0.0	0.0
JOURNALISM	2.5	0	0.0	0.0	0.0	0.0
LATIN	0.5	0.5	0.5	0.0	0.0	0.0
MATHEMATICS	173.5	24	22.0	0.0	0.0	2.0
MUSIC	77	2	1.0	0.0	1.0	0.0
ORAL COMMUNICATIONS	1	0	0.0	0.0	0.0	0.0
PHYSICAL EDUCATION	74	4.5	3.5	0.0	1.0	0.0
PHYSICS	8.5	2	2.0	0.0	0.0	0.0
PRESCHOOL EDUCATION	45	2.5	1.0	0.0	0.0	1.5
READING	57	4	2.0	0.0	2.0	0.0
READING SPECIALIST	155.5	20	18.0	0.0	2.0	0.0
RUSSIAN	0	0	0.0	0.0	0.0	0.0
SAFETY EDUCATION	5	0	0.0	0.0	0.0	0.0
SCHOOL LIBRARY/MEDIA	36	3	2.0	1.0	0.0	0.0
SOCIAL STUDIES	132	4.5	0.5	1.0	2.0	1.0
SPANISH	34.5	9	6.5	0.0	1.5	1.0
THEATER	2	0	0.0	0.0	0.0	0.0
WELLNESS	0	0	0.0	0.0	0.0	0.0
GENERAL EDUCATION TOTALS	2448	141.5	101	5	27	8.5
SPECIAL EDUCATION						
AMERICAN SIGN LANGUAGE	0	0	0.0	0.0	0.0	0.0
AUTISM	100	20	18.0	0.0	2.0	0.0
BEHAVIOR DISORDERS	55.5	16	14.0	0.0	2.0	0.0
GIFTED	33.5	6.5	6.5	0.0	0.0	0.0
HEARING IMPAIRED	9	1	1.0	0.0	0.0	0.0
MENTALLY IMPAIRED	47	9	9.0	0.0	0.0	0.0
MULTI-CATEGORICAL	302.5	45	37.0	0.0	8.0	0.0
PRESCHOOL SPECIAL NEEDS	64	9.5	9.5	0.0	0.0	0.0
SEVERELY/PROFOUNDLY IMPAIRED	13	3.5	3.5	0.0	0.0	0.0
SPECIFIC LEARNING DISABILITIES	52.5	7	6.0	0.0	1.0	0.0
VISUALLY IMPAIRED	11	1.5	1.5	0.0	0.0	0.0
SPECIAL EDUCATION TOTALS	688	119	106	0	13	0
ADMINISTRATIVE/SUPPORT						
ATHLETIC TRAINER	24	8	6.0	0.0	0.0	0.0
COUNSELOR	90	6	1.0	0.0	5.0	0.0
EDUCATIONAL AUDIOLOGIST	0	0	0.0	0.0	0.0	0.0
PRINCIPAL	158	0.5	0.5	0.0	0.0	0.0
SCHOOL BUSINESS OFFICIAL	13	0	0.0	0.0	0.0	0.0
SCHOOL NURSE	27	2	0.0	0.0	1.0	1.0
SCHOOL PSYCHOLOGIST	15	0	0.0	0.0	0.0	0.0
SOCIAL SERVICE AND ATTENDANCE	13	0	0.0	0.0	0.0	0.0
SPEECH LANGUAGE PATHOLOGIST	61	26	26.0	0.0	0.0	0.0
SUPERINTENDENT	12	1	0.0	0.0	0.0	1.0
SUPERVISOR OF INSTRUCTION	32	3	0.0	0.0	1.0	2.0
VOCATIONAL ADMINISTRATION	6.5	1	0.0	0.0	1.0	0.0
ADMINISTRATIVE/SUPPORT TOTALS	451.5	45.5	33.5	0	8	4
CAREER EDUCATION						
AGRICULTURE	6.5	0	0.0	0.0	0.0	0.0
BUSINESS EDUCATION	38.5	3	0.0	2.0	1.0	0.0
COMPUTER SCIENCE	5.5	0	0.0	0.0	0.0	0.0
FAMILY AND CONSUMER SCIENCE	19	3.5	3.5	0.0	0.0	0.0
MARKETING	0.5	0	0.0	0.0	0.0	0.0
TECHNOLOGY EDUCATION	45	2	1.0	0.0	0.0	1.0
CAREER EDUCATION TOTALS	113	8.5	4.5	2	1	1
OTHER SPECIALIZATIONS						
OTHER	100	6	2.0	1.0	3.0	0.0
TOTALS	3800.5	320.5	247	8	52	13.5

TABLE B3
WEST VIRGINIA FULL-TIME EQUIVALENCY
PROFESSIONAL POSTED POSITIONS BY SPECIALIZATION
2009 - 2010 SCHOOL YEAR

PROFESSIONAL SPECIALIZATIONS	2009 - 2010 TOTAL POSITIONS POSTED	2009 - 2010 POSTED POSITIONS FILLED	LICENSE HELD BY EMPLOYEE FOR ASSIGNMENT IN POSTED POSITION					POSITIONS FILLED BY EDUCATORS WITH PERMITS WHO HOLD A PROFESSIONAL OR VOCATIONAL CERTIFICATE IN ANOTHER AREA(S)
			PROFESSIONAL OR VOCATIONAL CERTIFICATE	TEMPORARY CERTIFICATE	OUT-OF-FIELD AUTHORIZATION	INTERNSHIPS & OTHER AUTHORIZATIONS	PERMIT	
	(1)	(2)	(3)	(4)	(5)	(6)	(7)	(8)
GENERAL EDUCATION								
ALTERNATIVE EDUCATION	26.5	21.5	16.0	1.0	0.0	1.5	4.0	1.0
ART	48	44.5	40.0	1.0	2.0	0.5	1.0	0.0
BIOLOGY	40.5	35	26.0	0.0	1.0	0.0	8.0	0.5
CHEMISTRY	20	19	12.0	0.5	1.0	0.0	8.5	0.0
CHINESE	1	1	0.0	0.0	0.0	0.0	1.0	0.0
DANCE	0	0	0.0	0.0	0.0	0.0	0.0	0.0
DRIVER EDUCATION/SAFETY EDUCATION	15.5	15	14.5	0.0	0.0	0.0	0.5	0.0
EARLY CHILDHOOD K-4	166	159	153.0	0.0	0.0	1.0	5.0	2.0
EARLY EDUCATION	54	54	50.0	0.0	1.0	0.0	3.0	1.0
ELEMENTARY EDUCATION	924	913.5	908.5	2.0	0.0	0.0	3.0	1.0
ENGLISH AS A SECOND LANGUAGE	6.5	4.5	3.0	0.0	0.5	0.0	1.0	0.0
ENGLISH/LANGUAGE ARTS	202.5	184.5	172.0	6.0	0.5	0.0	6.0	0.5
FRENCH	9.5	7.5	7.5	0.0	0.0	0.0	0.0	0.0
GENERAL SCIENCE	87	79	71.5	0.0	1.5	0.0	6.0	1.5
GERMAN	0.5	0.5	0.5	0.0	0.0	0.0	0.0	0.0
HEALTH	43.5	40	33.5	0.0	2.0	1.5	3.0	1.0
JAPANESE	0	0	0.0	0.0	0.0	0.0	0.0	0.0
JOURNALISM	2.5	2.5	2.5	0.0	0.0	0.0	0.0	0.0
LATIN	0.5	0	0.0	0.0	0.0	0.0	0.0	0.0
MATHEMATICS	173.5	149.5	128.0	5.5	3.0	1.0	12.0	1.0
MUSIC	77	75	73.0	0.0	1.0	0.0	1.0	0.0
ORAL COMMUNICATIONS	1	1	1.0	0.0	0.0	0.0	0.0	0.0
PHYSICAL EDUCATION	74	69.5	67.5	1.0	0.0	0.0	1.0	0.0
PHYSICS	8.5	6.5	2.0	0.5	0.0	0.0	4.0	0.0
PRESCHOOL EDUCATION	45	42.5	39.0	0.0	0.0	0.0	3.5	1.5
READING	57	53	47.5	0.0	1.0	0.0	4.5	1.0
READING SPECIALIST	155.5	135.5	103.0	0.0	18.0	0.0	14.5	6.0
RUSSIAN	0	0	0.0	0.0	0.0	0.0	0.0	0.0
SAFETY EDUCATION	5	5	5.0	0.0	0.0	0.0	0.0	0.0
SCHOOL LIBRARY/MEDIA	36	33	24.5	0.0	1.5	0.0	7.0	1.0
SOCIAL STUDIES	132	127.5	126.0	0.5	0.0	0.0	1.0	0.0
SPANISH	34.5	26.5	15.5	0.0	2.5	0.0	7.5	0.0
THEATER	2	2	2.0	0.0	0.0	0.0	0.0	0.0
WELLNESS	0	0	0.0	0.0	0.0	0.0	0.0	0.0
GENERAL EDUCATION TOTALS	2448	2306.5	2143.5	18	36.5	5.5	103	19
SPECIAL EDUCATION								
AMERICAN SIGN LANGUAGE	0	0	0.0	0.0	0.0	0.0	0.0	0.0
AUTISM	100	80	18.5	0.0	15.5	0.0	46.0	7.5
BEHAVIOR DISORDERS	55.5	39.5	23.0	0.0	7.5	0.0	9.0	2.0
GIFTED	33.5	27	7.5	0.0	16.0	0.0	3.5	2.0
HEARING IMPAIRED	9	8	6.0	0.0	0.0	0.0	2.0	0.0
MENTALLY IMPAIRED	47	38	25.0	0.0	4.0	2.0	7.0	1.0
MULTI-CATEGORICAL	302.5	257.5	146.5	0.0	33.5	4.0	73.5	17.0
PRESCHOOL SPECIAL NEEDS	64	54.5	25.0	0.0	13.5	0.0	16.0	4.0
SEVERELY/PROFOUNDLY IMPAIRED	13	9.5	6.5	0.0	1.0	0.0	3.0	0.0
SPECIFIC LEARNING DISABILITIES	52.5	46.5	36.0	0.0	1.5	0.0	8.0	0.5
VISUALLY IMPAIRED	11	9.5	2.0	0.0	2.0	0.0	5.5	1.0
SPECIAL EDUCATION TOTALS	688	569	295	0	94.5	6	173.5	35
ADMINISTRATIVE/SUPPORT								
ATHLETIC TRAINER	24	18	4.0	2.0	1.0	2.0	9.0	2.0
COUNSELOR	90	84	77.5	0.0	0.5	0.0	6.0	1.0
EDUCATIONAL AUDIOLOGIST	0	0	0.0	0.0	0.0	0.0	0.0	0.0
PRINCIPAL	158	157.5	164.5	3.0	0.0	0.0	0.0	0.0
SCHOOL BUSINESS OFFICIAL	13	13	5.0	7.0	0.0	1.0	0.0	0.0
SCHOOL NURSE	27	26	13.0	1.0	1.0	2.0	8.0	0.0
SCHOOL PSYCHOLOGIST	15	15	12.0	0.0	0.0	0.0	3.0	0.0
SOCIAL SERVICE AND ATTENDANCE	13	13	9.5	1.0	0.0	0.5	2.0	1.0
SPEECH LANGUAGE PATHOLOGIST	61	35	27.0	5.0	0.0	1.0	2.0	0.0
SUPERINTENDENT	12	11	11.0	0.0	0.0	0.0	0.0	0.0
SUPERVISOR OF INSTRUCTION	32	29	29.0	0.0	0.0	0.0	0.0	0.0
VOCATIONAL ADMINISTRATION	6.5	5.5	5.0	0.0	0.0	0.0	0.5	0.0
ADMINISTRATIVE/SUPPORT TOTALS	451.5	406	347.5	19	2.5	6.5	30.5	4
CAREER EDUCATION								
AGRICULTURE	6.5	6.5	6.0	0.0	0.5	0.0	0.0	0.0
BUSINESS EDUCATION	36.5	33.5	30.5	0.0	0.0	0.0	3.0	0.0
COMPUTER SCIENCE	5.5	5.5	5.0	0.0	0.0	0.0	0.5	0.5
FAMILY AND CONSUMER SCIENCE	19	15.5	8.5	0.0	2.0	0.0	5.0	0.0
MARKETING	0.5	0.5	0.5	0.0	0.0	0.0	0.0	0.0
TECHNOLOGY EDUCATION	45	43	38.5	0.5	1.0	0.0	3.0	0.0
CAREER EDUCATION TOTALS	113	104.5	89	0.5	3.5	0	11.5	0.5
OTHER SPECIALIZATIONS								
OTHER	100	94	74.0	4.0	0.0	7.0	9.0	1.0
TOTALS	3800.5	3480	2949	41.5	137	25	327.5	59.5

TABLE B4
WEST VIRGINIA FULL-TIME EQUIVALENCY
REASONS FOR NON-RETURNING EDUCATORS
2008 - 2010 SCHOOL YEAR

PROFESSIONAL SPECIALIZATIONS	TOTAL NON-RETURNING EDUCATORS	REASONS FOR PROFESSIONAL EDUCATORS EMPLOYED IN 2008 - 2009 NOT RETURNING IN 2009 - 2010									
		RETIRED	DECEASED	TERMINATED DUE TO A REDUCTION IN FORCE (RIF)	TERMINATED DUE TO REASONS OTHER THAN RIF	RESIGNED TO ACCEPT AN EDUCATION POSITION IN WV	RESIGNED TO ACCEPT AN EDUCATION POSITION OUT-OF-STATE	RESIGNED TO ACCEPT EMPLOYMENT IN A NON-EDUCATION POSITION	RESIGNED TO PURSUE FULL-TIME GRADUATE STUDIES	RECEIVED A LEAVE OF ABSENCE	OTHER / UNKNOWN
	(1)	(2)	(3)	(4)	(5)	(6)	(7)	(8)	(9)	(10)	(11)
GENERAL EDUCATION											
ALTERNATIVE EDUCATION	4	0.0	0.0	0.0	0.0	3.0	0.0	0.0	0.0	0.0	1.0
ART	19.5	13.0	0.0	0.0	2.0	0.5	0.0	0.0	0.0	2.0	2.0
BIOLOGY	12.5	7.0	0.0	0.0	0.5	2.5	1.5	0.5	0.0	0.0	0.5
CHEMISTRY	4.5	1.0	0.0	0.0	0.0	2.5	0.0	0.5	0.0	0.0	0.5
CHINESE	1	0.0	0.0	0.0	0.0	0.0	0.0	0.0	0.0	0.0	1.0
DANCE	0	0.0	0.0	0.0	0.0	0.0	0.0	0.0	0.0	0.0	0.0
DRIVER EDUCATION/SAFETY EDUCATION	10	6.0	0.0	0.0	1.0	1.0	0.5	0.0	0.0	0.0	1.5
EARLY CHILDHOOD K-4	80	42.0	0.0	0.0	0.0	26.0	1.0	1.0	1.0	3.0	6.0
EARLY EDUCATION	12	6.0	0.0	1.0	0.0	5.0	0.0	0.0	0.0	0.0	0.0
ELEMENTARY EDUCATION	295.5	194.0	4.0	1.0	0.0	55.0	14.0	4.5	1.0	4.0	18.0
ENGLISH AS A SECOND LANGUAGE	0.5	0.0	0.0	0.0	0.0	0.0	0.0	0.0	0.0	0.0	0.5
ENGLISH LANGUAGE ARTS	104	65.5	0.0	1.0	2.0	16.5	7.0	3.0	0.0	1.0	8.0
FRENCH	2.5	2.5	0.0	0.0	0.0	0.0	0.0	0.0	0.0	0.0	0.0
GENERAL SCIENCE	37	17.5	1.0	0.0	1.5	4.5	4.0	2.0	0.0	4.0	2.5
GERMAN	0	0.0	0.0	0.0	0.0	0.0	0.0	0.0	0.0	0.0	0.0
HEALTH	17.5	10.0	0.0	0.0	1.0	1.5	1.0	2.5	0.0	1.0	0.5
JAPANESE	0	0.0	0.0	0.0	0.0	0.0	0.0	0.0	0.0	0.0	0.0
JOURNALISM	2	2.0	0.0	0.0	0.0	0.0	0.0	0.0	0.0	0.0	0.0
LATIN	0.5	0.5	0.0	0.0	0.0	0.0	0.0	0.0	0.0	0.0	0.0
MATHEMATICS	57.5	31.0	0.0	0.0	1.0	9.0	6.0	5.0	0.0	3.0	2.5
MUSIC	39	18.5	0.0	2.0	0.0	9.0	3.0	1.0	0.0	0.0	5.5
ORAL COMMUNICATIONS	0	0.0	0.0	0.0	0.0	0.0	0.0	0.0	0.0	0.0	0.0
PHYSICAL EDUCATION	36.5	20.0	0.0	0.5	0.0	4.5	2.5	1.0	0.0	4.0	3.0
PHYSICS	4	2.5	0.0	0.0	0.0	1.0	0.0	0.0	0.0	0.0	0.5
PRESCHOOL EDUCATION	8.5	2.5	0.0	1.0	0.0	3.0	0.0	0.0	0.0	1.0	1.0
READING	13	4.0	0.0	0.0	0.0	4.0	0.0	0.0	0.0	3.0	2.0
READING SPECIALIST	32.5	13.5	0.0	0.0	1.0	9.0	3.0	3.0	0.0	0.0	3.0
RUSSIAN	0	0.0	0.0	0.0	0.0	0.0	0.0	0.0	0.0	0.0	0.0
SAFETY EDUCATION	1	1.0	0.0	0.0	0.0	0.0	0.0	0.0	0.0	0.0	0.0
SCHOOL LIBRARY/MEDIA	12.5	11.0	0.0	0.0	0.0	0.0	1.0	0.0	0.0	0.0	0.5
SOCIAL STUDIES	74.5	48.5	1.0	1.0	0.0	10.0	5.0	4.5	1.0	2.0	3.5
SPANISH	18.5	7.0	1.0	0.0	0.0	3.5	1.0	2.0	0.0	0.0	4.0
THEATER	0	0.0	0.0	0.0	0.0	0.0	0.0	0.0	0.0	0.0	0.0
WELLNESS	0	0.0	0.0	0.0	0.0	0.0	0.0	0.0	0.0	0.0	0.0
GENERAL EDUCATION TOTALS	899.5	524.5	7	7.5	10	171	50.5	30.5	3	28	67.5
SPECIAL EDUCATION											
AMERICAN SIGN LANGUAGE	0	0.0	0.0	0.0	0.0	0.0	0.0	0.0	0.0	0.0	0.0
AUTISM	19	12.0	0.0	0.0	0.0	5.0	1.0	0.0	0.0	0.0	1.0
BEHAVIOR DISORDERS	7.5	3.0	0.0	0.5	0.0	4.0	0.0	0.0	0.0	0.0	0.0
GIFTED	13.5	8.0	0.0	0.0	0.0	1.0	0.0	0.0	0.0	0.0	4.5
HEARING IMPAIRED	4	2.0	0.0	0.0	0.0	2.0	0.0	0.0	0.0	0.0	0.0
MENTALLY IMPAIRED	9.5	2.5	1.0	2.0	0.0	2.0	1.0	0.0	0.0	0.0	1.0
MULTI-CATEGORICAL	86	27.0	1.0	3.0	0.0	28.0	6.0	2.0	0.0	4.0	15.0
PRESCHOOL SPECIAL NEEDS	13	1.0	0.0	0.0	0.0	4.0	5.0	1.0	0.0	1.0	1.0
SEVERELY/PROFOUNDLY IMPAIRED	4	1.0	0.0	0.0	0.0	2.0	1.0	0.0	0.0	0.0	0.0
SPECIFIC LEARNING DISABILITIES	20.5	7.5	1.0	0.5	0.0	4.5	1.0	1.0	0.0	0.0	5.0
VISUALLY IMPAIRED	4.5	0.0	0.0	0.0	0.0	2.5	0.0	0.0	0.0	0.0	2.0
SPECIAL EDUCATION TOTALS	181.5	64	3	6	0	55	15	4	0	5	29.5
ADMINISTRATIVE/SUPPORT											
ATHLETIC TRAINER	5	0.0	0.0	0.0	0.0	1.0	0.0	2.0	0.0	0.0	2.0
COUNSELOR	41.5	18.0	0.0	0.0	0.0	10.5	4.0	2.0	0.0	0.0	7.0
EDUCATIONAL AUDIOLOGIST	0	0.0	0.0	0.0	0.0	0.0	0.0	0.0	0.0	0.0	0.0
PRINCIPAL	72.5	42.0	1.0	0.0	1.0	24.0	1.0	0.5	1.0	0.0	2.0
SCHOOL BUSINESS OFFICIAL	9	5.0	0.0	0.0	1.0	3.0	0.0	0.0	0.0	0.0	0.0
SCHOOL NURSE	11	5.0	0.0	0.0	0.0	0.0	0.0	5.0	0.0	0.0	1.0
SCHOOL PSYCHOLOGIST	7	4.0	0.0	0.0	0.0	2.0	1.0	0.0	0.0	0.0	0.0
SOCIAL SERVICE AND ATTENDANCE	6.5	1.5	0.0	0.0	1.0	1.0	1.0	0.0	0.0	0.0	2.0
SPEECH LANGUAGE PATHOLOGIST	31	11.5	0.0	1.0	0.0	5.0	2.0	3.0	0.0	0.0	8.5
SUPERINTENDENT	11	6.0	0.0	0.0	1.0	3.0	0.0	0.0	0.0	0.0	1.0
SUPERVISOR OF INSTRUCTION	8	6.0	0.0	0.0	0.0	2.0	0.0	0.0	0.0	0.0	0.0
VOCATIONAL ADMINISTRATION	7.5	4.0	0.0	0.0	0.0	2.5	1.0	0.0	0.0	0.0	0.0
ADMINISTRATIVE/SUPPORT TOTALS	210	103	1	1	4	54	10	12.5	1	0	23.5
CAREER EDUCATION											
AGRICULTURE	4	2.0	0.0	0.0	0.0	2.0	0.0	0.0	0.0	0.0	0.0
BUSINESS EDUCATION	19	14.0	1.0	0.0	0.0	2.0	0.0	0.0	0.0	1.0	1.0
COMPUTER SCIENCE	0	0.0	0.0	0.0	0.0	0.0	0.0	0.0	0.0	0.0	0.0
FAMILY AND CONSUMER SCIENCE	11.5	9.0	0.0	0.0	0.0	0.0	0.0	0.0	0.0	1.0	1.5
MARKETING	0.5	0.0	0.0	0.0	0.0	0.0	0.0	0.0	0.0	0.0	0.5
TECHNOLOGY EDUCATION	17	4.0	0.0	1.0	0.0	5.0	0.0	2.0	0.0	0.0	5.0
CAREER EDUCATION TOTALS	52	29	1	1	0	9	0	2	0	2	8
OTHER SPECIALIZATIONS											
OTHER	27	13.0	0.0	0.0	0.0	5.5	1.0	6.0	0.0	0.0	1.5
TOTALS	1370	733.5	12	15.5	14	294.5	76.5	55	4	35	130

TABLE B5
WEST VIRGINIA TREND DATA AS REPORTED BY COUNTIES RELATED TO THE
EMPLOYMENT OF EDUCATORS ON LESS THAN A PROFESSIONAL LICENSE
BETWEEN 2008- 2010

PROFESSIONAL SPECIALIZATIONS	2007- 2008			2008- 2009			2009- 2010		
	OUT OF FIELD AUTHORIZATION	PERMIT	PERMIT HELD WITH PROFESSIONAL LICENSE	OUT OF FIELD AUTHORIZATION	PERMIT	PERMIT HELD WITH PROFESSIONAL LICENSE	OUT OF FIELD AUTHORIZATION	PERMIT	PERMIT HELD WITH PROFESSIONAL LICENSE
	(1)	(2)	(3)	(4)	(5)	(6)	(7)	(8)	(9)
GENERAL EDUCATION									
ALTERNATIVE EDUCATION	0.0	2.0	2.0	1.0	0.0	3.5	0.0	4.0	1.0
ART	1.5	0.0	2.0	0.0	4.5	0.0	2.0	1.0	0.0
BIOLOGY	0.0	2.0	1.0	2.0	3.0	0.0	1.0	8.0	0.5
CHEMISTRY	0.5	2.0	1.5	1.0	5.5	0.0	1.0	5.5	0.0
CHINESE	0.0	0.0	0.0	0.0	0.0	0.0	0.0	1.0	0.0
DANCE	0.0	0.0	0.0	0.0	0.0	0.0	0.0	0.0	0.0
DRIVER/SAFETY EDUCATION	0.0	0.5	0.0	0.5	0.5	0.0	0.0	0.5	0.0
EARLY CHILDHOOD K- 4	0.0	0.0	0.0	0.0	0.0	0.0	0.0	5.0	2.0
EARLY EDUCATION	4.0	0.0	2.0	4.5	3.0	2.0	1.0	3.0	1.0
ELEMENTARY EDUCATION	0.0	3.0	0.0	0.0	4.0	0.0	0.0	3.0	1.0
ENGLISH AS A SECOND LANGUAGE	0.0	0.0	0.0	0.0	0.0	0.0	0.5	1.0	0.0
ENGLISH/LANGUAGE ARTS	4.0	11.5	6.5	4.5	17.0	0.0	0.5	6.0	0.5
FRENCH	0.0	0.0	0.0	0.0	0.0	0.0	0.0	0.0	0.0
GENERAL SCIENCE	1.5	14.0	2.5	4.0	17.5	0.0	1.5	6.0	1.5
GERMAN	0.0	0.0	0.0	0.0	0.0	0.0	0.0	0.0	0.0
HEALTH	2.3	2.8	2.8	2.0	4.0	2.0	2.0	3.0	1.0
JAPANESE	0.0	0.0	0.0	0.0	0.0	0.0	0.0	0.0	0.0
JOURNALISM	0.0	0.0	0.0	0.0	0.0	0.0	0.0	0.0	0.0
LATIN	0.0	1.0	0.0	0.0	0.0	0.0	0.0	0.0	0.0
MATHEMATICS	4.0	13.0	4.0	6.0	21.0	1.0	3.0	12.0	1.0
MUSIC	0.0	2.0	0.0	0.0	2.5	0.0	1.0	1.0	0.0
ORAL COMMUNICATIONS	0.0	0.0	0.0	0.0	0.0	0.0	0.0	0.0	0.0
PHYSICAL EDUCATION	4.1	2.3	0.0	1.0	0.0	1.0	0.0	1.0	0.0
PHYSICS	0.0	2.5	0.0	0.0	1.0	0.0	0.0	4.0	0.0
PRESCHOOL EDUCATION	0.0	0.0	0.0	0.0	0.0	0.0	0.0	3.5	1.5
READING	0.0	0.0	0.0	0.0	0.0	0.0	1.0	4.5	1.0
READING SPECIALIST	21.0	14.0	16.0	33.5	35.5	21.5	18.0	14.5	6.0
RUSSIAN	0.0	0.0	0.0	0.0	0.0	0.0	0.0	0.0	0.0
SCHOOL LIBRARY/MEDIA	6.5	1.0	3.0	5.5	7.5	7.0	0.0	0.0	0.0
SOCIAL STUDIES	2.5	2.0	2.8	0.5	3.0	0.0	1.5	7.0	1.0
SPANISH	3.0	7.0	2.0	1.0	9.0	2.0	0.0	1.0	0.0
THEATER	0.0	0.0	0.0	0.0	0.0	0.0	2.5	7.5	0.0
WELLNESS	0.0	0.0	0.0	0.0	0.0	0.0	0.0	0.0	0.0
GENERAL EDUCATION TOTALS	54.8	82.5	48.1	67.0	138.5	40.0	36.5	103.0	19.0
SPECIAL EDUCATION									
AMERICAN SIGN LANGUAGE							0.0	0.0	0.0
AUTISM				12.0	18.0	3.0	15.5	46.0	7.5
BEHAVIOR DISORDERS	8.3	7.0	3.0	2.0	3.0	0.0	7.5	9.0	2.0
GIFTED	11.0	4.0	4.0	14.5	7.5	8.0	16.0	3.5	2.0
HEARING IMPAIRED	2.0	0.0	0.0	2.0	3.0	1.0	0.0	2.0	0.0
MENTALLY IMPAIRED	6.8	6.0	2.0	3.0	3.0	0.0	4.0	7.0	1.0
MULTI-CATEGORICAL	48.5	53.5	46.5	42.5	110.5	40.5	33.5	73.5	17.0
PRESCHOOL SPECIAL NEEDS	7.0	0.0	5.0	21.0	14.0	10.0	13.5	16.0	4.0
SEVERELY/PROFOUNDLY IMPAIRED	4.5	0.0	5.0	4.5	8.0	5.5	1.0	3.0	0.0
SPECIFIC LEARNING DISABILITIES	4.8	11.0	3.0	6.0	5.5	0.0	1.5	8.0	0.5
VISUALLY IMPAIRED	2.0	1.5	1.0	2.5	3.5	1.0	2.0	5.5	1.0
SPECIAL EDUCATION TOTALS	95.0	83.0	69.5	110.0	176.0	69.0	94.5	173.5	35.0
ADMINISTRATIVE/SUPPORT									
ATHLETIC TRAINER	0.0	3.0	0.0	0.0	5.0	0.0	1.0	9.0	2.0
COUNSELOR	2.0	7.0	0.0	2.0	18.0	0.0	0.5	6.0	1.0
EDUCATIONAL AUDIOLOGIST	0.0	0.0	0.0	0.0	0.0	0.0	0.0	0.0	0.0
PRINCIPAL	0.0	0.0	1.0	0.0	2.0	1.0	0.0	0.0	0.0
SCHOOL BUSINESS OFFICIAL	0.0	0.0	0.0	0.0	0.0	0.0	0.0	0.0	0.0
SCHOOL NURSE	0.0	12.0	0.0	0.0	15.0	0.0	1.0	8.0	0.0
SCHOOL PSYCHOLOGIST	0.0	0.0	0.0	0.0	0.0	0.0	0.0	3.0	0.0
SOCIAL SERVICE & ATTENDANCE	0.0	2.0	0.0	0.0	2.0	0.0	0.0	2.0	1.0
SPEECH LANGUAGE PATHOLOGIST	1.0	2.0	0.0	0.0	2.5	0.0	0.0	2.0	0.0
SUPERINTENDENT	0.0	0.0	0.0	0.0	1.0	0.0	0.0	0.0	0.0
SUPERVISOR OF INSTRUCTION	0.0	1.0	1.0	0.0	0.0	0.0	0.0	0.0	0.0
VOCATIONAL ADMINISTRATION	0.0	1.0	1.0	0.0	0.5	0.0	0.0	0.5	0.0
ADMIN/SUPPORT TOTALS	3.0	28.0	3.0	2.0	46.0	1.0	2.5	30.5	4.0
CAREER EDUCATION									
AGRICULTURE	0.0	0.0	0.0	0.0	3.0	2.0	0.5	0.0	0.0
BUSINESS EDUCATION	0.0	2.0	0.0	1.0	2.5	1.0	0.0	3.0	0.0
COMPUTER SCIENCE	0.0	0.0	0.0	0.0	0.0	0.0	0.0	0.5	0.5
FAMILY & CONSUMER SCIENCE	3.0	1.0	0.0	2.5	2.5	1.0	2.0	5.0	0.0
MARKETING	0.0	0.5	0.0	0.0	2.0	1.0	0.0	0.0	0.0
TECHNOLOGY EDUCATION	2.0	8.5	0.0	0.0	3.5	4.0	1.0	3.0	0.0
VOCATIONAL EDUCATION TOTALS	5.0	12.0	0.0	3.5	13.5	9.0	3.5	11.5	0.5
OTHER SPECIALIZATIONS	4.1	16.0	3.0	3.5	11.0	8.0	0.0	9.0	1.0
TOTALS	161.9	221.5	123.6	186.0	385.0	127.0	137.0	327.5	59.5

TABLE B6
WEST VIRGINIA TREND DATA FOR TOTAL POSITIONS POSTED
TOTAL NON-RETURNING EDUCATORS
TERMINATED DUE TO A REDUCATION IN FORCE
BETWEEN 2008-2010

PROFESSIONAL SPECIALIZATIONS	2007-2008			2008-2009			2009-2010		
	TOTAL POSITIONS POSTED	TOTAL NON-RETURNING EDUCATORS	TERMINATED DUE TO A REDUCATION IN FORCE	TOTAL POSITIONS POSTED	TOTAL NON-RETURNING EDUCATORS	TERMINATED DUE TO A REDUCATION IN FORCE	TOTAL POSITIONS POSTED	TOTAL NON-RETURNING EDUCATORS	TERMINATED DUE TO A REDUCATION IN FORCE
	(1)	(2)	(3)	(4)	(5)	(6)	(7)	(8)	(9)
GENERAL EDUCATION									
ALTERNATIVE EDUCATION	28.00	8.00	1.00	28.50	15.00	1.00	25.50	4.00	0.00
ART	66.50	28.50	0.00	71.50	31.50	0.00	48.00	19.50	0.00
BIOLOGY	26.00	13.00	1.00	35.50	20.00	0.00	40.50	12.50	0.00
CHEMISTRY	18.00	7.50	0.00	30.00	20.00	1.00	20.00	4.50	0.00
CHINESE	0.00	0.00	0.00	0.00	0.00	0.00	1.00	1.00	0.00
DANCE	0.00	0.00	0.00	0.00	0.00	0.00	0.00	0.00	0.00
DRIVER SAFETY EDUCATION	0.00	0.00	0.00	0.00	0.00	0.00	15.50	10.00	0.00
EARLY CHILDHOOD K-4	0.00	0.00	0.00	0.00	0.00	0.00	186.00	80.00	0.00
EARLY EDUCATION	140.50	46.66	0.00	181.50	38.50	2.00	54.00	12.00	1.00
ELEMENTARY EDUCATION	1028.00	390.16	52.00	1189.50	362.50	7.00	924.00	295.50	1.00
ENGLISH AS A SECOND LANGUAGE	0.00	0.00	0.00	0.00	0.00	0.00	6.50	0.50	0.00
ENGLISH LANGUAGE ARTS	253.00	148.50	5.00	281.00	117.50	2.50	202.50	104.00	1.00
FRENCH	8.50	7.00	0.00	9.50	6.00	0.00	9.50	2.50	0.00
GENERAL SCIENCE	128.50	54.00	0.00	125.00	44.50	1.00	87.00	37.00	0.00
GERMAN	1.00	0.00	0.00	1.00	1.00	0.00	0.50	0.00	0.00
HEALTH	46.91	20.33	0.00	46.50	16.50	1.00	43.50	17.50	0.00
JAPANESE	0.00	0.00	0.00	0.00	0.00	0.00	0.00	0.00	0.00
KORNEAN	0.50	1.00	0.00	2.50	0.00	0.00	2.50	2.00	0.00
LATIN	1.00	1.00	0.00	0.00	0.00	0.00	0.50	0.50	0.00
MATHEMATICS	213.50	71.50	1.00	229.00	80.00	1.50	173.50	57.50	0.00
MUSIC	58.50	60.00	1.00	106.00	34.00	2.00	77.00	39.00	2.00
ORAL COMMUNICATIONS	2.00	0.00	0.00	8.00	2.00	0.00	1.00	0.00	0.00
PHYSICAL EDUCATION	121.50	52.17	0.00	107.50	32.00	0.50	74.00	35.50	0.50
PHYSICS	8.50	5.50	0.00	10.00	1.50	0.00	8.50	4.00	0.00
PRESCHOOL EDUCATION	0.00	0.00	0.00	0.00	0.00	0.00	45.00	8.50	1.00
READING	0.00	0.00	0.00	0.00	0.00	0.00	57.00	13.00	0.00
READING SPECIALIST	208.50	58.50	0.00	243.50	80.50	3.00	155.50	32.50	0.00
RUSSIAN	0.00	0.00	0.00	0.00	0.00	0.00	0.00	0.00	0.00
SAFETY EDUCATION	15.83	9.83	1.00	12.50	7.00	0.00	5.00	1.00	0.00
SCHOOL LIBRARY/MEDIA	36.50	24.50	0.00	40.50	19.50	1.00	36.00	12.50	0.00
SOCIAL STUDIES	168.82	72.43	2.50	153.00	75.00	2.50	132.00	74.50	1.00
SPANISH	64.50	20.50	0.00	57.50	19.00	0.00	34.50	18.50	0.00
THEATRE	0.00	0.00	0.00	0.00	0.00	0.00	2.00	0.00	0.00
WELLNESS	0.00	0.00	0.00	0.00	0.00	0.00	0.00	0.00	0.00
GENERAL EDUCATION TOTALS	2686.76	1100.58	64.50	2969.50	1005.50	26.00	2448.00	899.50	7.50
SPECIAL EDUCATION									
AFRICAN SIGN LANGUAGE							0.00	0.00	0.00
ALBEM				66.00	12.00	0.00	100.00	19.00	0.00
BEHAVIOR DISORDERS	54.33	12.32	0.00	47.00	3.50	0.00	65.50	7.50	0.50
GIFTED	41.00	9.00	0.00	45.50	12.00	0.00	33.50	13.50	0.00
HEARING IMPAIRED	9.17	1.00	0.00	13.50	4.00	0.00	9.00	4.00	0.00
MENTALLY IMPAIRED	57.33	13.32	0.00	39.50	12.00	1.50	47.00	9.50	2.00
MULTI-CULTURAL	387.00	84.50	8.50	432.00	106.50	2.00	302.50	86.00	3.00
PRESCHOOL SPECIAL NEEDS	75.75	14.50	0.00	88.00	16.00	0.00	64.00	13.00	0.00
SEVERELY/PROFOUNDLY IMPAIRED	22.50	12.00	0.00	33.50	6.00	0.00	13.00	4.00	0.00
SPECIFIC LEARNING DISABILITIES	45.84	14.38	0.00	47.50	6.50	0.00	52.50	20.50	0.50
VISUALLY IMPAIRED	9.00	3.00	0.00	15.00	6.00	0.00	11.00	4.50	0.00
SPECIAL EDUCATION TOTALS	701.92	164.00	8.50	827.50	186.50	3.50	688.00	181.50	6.00
ADMINISTRATIVE SUPPORT									
ATHLETIC TRAINER	27.00	9.00	0.00	28.00	3.00	0.00	24.00	5.00	0.00
COUNSELOR	102.00	48.00	1.00	137.00	52.50	0.00	90.00	41.50	0.00
EDUCATIONAL AUDIOLOGIST	0.16	0.00	0.00	0.60	0.00	0.00	0.00	0.00	0.00
PRINCIPAL	180.00	95.00	0.00	180.50	86.00	0.00	158.00	72.50	0.00
SCHOOL BUSINESS OFFICIAL	9.00	6.00	0.00	4.00	2.00	0.00	13.00	9.00	0.00
SCHOOL NURSE	23.50	9.00	0.00	27.50	15.00	0.00	27.00	11.00	0.00
SCHOOL PSYCHOLOGIST	8.00	7.00	0.00	9.00	4.00	0.00	15.00	7.00	0.00
SOCIAL SERVICE & ATTENDANCE	14.50	6.00	0.00	6.00	3.00	1.00	13.00	6.50	0.00
SPEECH LANGUAGE PATHOLOGIST	61.17	26.50	0.00	73.50	27.50	0.00	61.00	31.00	1.00
SUPERINTENDENT	12.00	12.00	0.00	8.00	4.00	0.00	12.00	11.00	0.00
SUPERVISOR OF INSTRUCTION	33.00	22.00	0.00	36.00	12.00	0.00	32.00	8.00	0.00
VOCATIONAL ADMINISTRATION	4.00	2.00	0.00	1.50	2.00	0.00	6.50	7.50	0.00
ADMINISTRATIVE SUPPORT TOTALS	474.33	242.50	1.00	511.00	211.00	1.00	451.50	210.00	1.00
CAREER EDUCATION									
AGRICULTURE	10.00	8.00	0.00	14.00	7.00	1.00	6.50	4.00	0.00
BUSINESS EDUCATION	31.50	19.00	1.00	39.50	27.50	1.00	36.50	19.00	0.00
COMPUTER SCIENCE	0.00	0.00	0.00	0.00	0.00	0.00	5.50	0.00	0.00
FAMILY & CONSUMER SCIENCE	24.50	17.00	0.50	29.00	11.00	0.00	19.00	11.50	0.00
MARKETING	0.50	0.50	0.00	2.50	2.50	0.00	0.50	0.50	0.00
TECHNOLOGY EDUCATION	37.50	16.50	0.00	34.00	15.00	0.00	45.00	17.00	1.00
VOCATIONAL EDUCATION TOTALS	104.00	59.00	1.50	119.00	63.00	2.00	113.00	52.00	1.00
OTHER SPECIALIZATIONS	107.10	38.00	0.00	165.50	54.00	0.00	100.00	27.00	0.00
TOTALS	4074.11	1604.08	75.50	4582.50	1520.00	32.50	3800.50	1370.00	15.50

**CLASSIFICATION OF SERVICE PERSONNEL
BY ASSIGNMENT AND FUNDING SOURCE (FTE BASIS)*
AS OF SECOND SCHOOL MONTH
(EXCLUDING RESA PERSONNEL)
2009-10 YEAR**

Position Assignment	State Aid Eligible	Other State Funds	Federal Funds	County Funds	Other Sources	Total
Aide	2,149.16	5.00	498.33	4.75	-	2,657.24
Licensed Practical Nurse	61.50	-	12.20	-	-	73.70
Paraprofessional	306.76	1.37	112.00	1.00	-	421.13
Autism Mentor	257.85	0.50	114.40	0.25	-	373.00
Director or Coordinator of Services	109.17	-	4.50	2.00	-	115.67
Accountant	122.17	-	6.72	0.50	-	129.39
Auditor	22.25	-	1.00	-	-	23.25
Buyer	6.00	-	-	-	-	6.00
Braille/Sign Language Specialist	53.24	0.50	27.52	-	-	81.26
Clerk	80.10	1.00	5.15	0.25	-	86.50
Secretary	1,434.08	8.40	52.85	5.58	-	1,500.91
Switchboard Operator/Receptionist	4.15	-	-	-	-	4.15
Computer Operator	39.98	-	-	-	-	39.98
Programmer	25.65	-	-	-	-	25.65
Draftsman	2.00	-	-	-	-	2.00
Graphic Artist	2.00	-	-	-	-	2.00
Inventory Supervisor	10.31	-	-	-	-	10.31
Printing Operator	0.25	-	-	-	-	0.25
Printing Supervisor	1.00	-	-	-	-	1.00
Accounts Payable Supervisor	21.00	-	-	-	-	21.00
Payroll Supervisor	17.58	-	-	-	-	17.58
Supervisor of Maintenance	36.75	-	-	-	-	36.75
Audiovisual Technician	1.00	-	-	-	-	1.00
Cabinet Maker	23.00	-	-	-	-	23.00
Carpenter	71.65	1.00	-	-	-	72.65
Chief Mechanic	39.65	-	-	-	-	39.65
Crew Leader	18.10	-	-	-	-	18.10
Electrician	96.22	-	-	-	-	96.22
Electronic Technician	33.93	-	-	-	-	33.93
Foreman	46.94	-	-	-	-	46.94
General Maintenance	50.53	-	-	-	-	50.53
Glazier	3.58	-	-	-	-	3.58
Handyman	8.49	-	-	-	-	8.49
Heating & Air Conditioning Mechanic	67.01	-	-	-	-	67.01
Locksmith	15.83	-	-	-	-	15.83
Lubrication Man	0.50	-	-	-	-	0.50
Mason	27.07	-	-	-	-	27.07
Mechanic Assistant	3.75	-	-	-	-	3.75
Mechanic	192.00	-	-	-	-	192.00
Office Equipment Repairman	5.25	-	-	-	-	5.25
Painter	35.21	-	-	-	-	35.21
Plumber	87.49	-	-	-	-	87.49
Roofing/Sheet Metal Mechanic	9.37	-	-	-	-	9.37
Welder	9.52	-	-	-	-	9.52
Supervisor of Transportation	36.00	-	-	-	-	36.00
School Bus Supervisor	11.50	-	-	-	-	11.50
Bus Operator	2,846.54	-	16.00	-	-	2,862.54
Heavy Equipment Operator	13.33	-	-	-	-	13.33
Truck Driver	51.22	-	0.50	-	-	51.72
Food Services Supervisor	4.00	-	-	-	-	4.00
Cafeteria Manager	405.44	-	-	-	-	405.44
Cook	1,768.40	-	-	-	-	1,768.40
Custodian	2,197.26	0.66	1.80	1.00	-	2,200.72
Groundsman	4.61	-	-	-	-	4.61
Watchman	1.15	-	-	-	-	1.15
Sanitation Plant Operator	16.94	-	0.50	-	-	17.44
Total	12,965.43	18.43	853.47	15.33	-	13,852.66

Note: Service personnel are presented on a regular FTE basis with full-time personnel employed beyond 200 days counted as 1.00, as opposed to an extended FTE basis where the FTE is determined by dividing each employee's number of days employed by 200 days.

OSF

01/13/10

Classification Report 10

**DISTRIBUTION OF SERVICE PERSONNEL (FTE BASIS)
BY PAY GRADE AND YEARS OF EXPERIENCE
ALL FUNDING SOURCES - ALL DISTRICTS
2009-10 YEAR**

Years Exp.	PAY GRADE										Total
	A	B	C	D	E	F	G	H	Total		
0	35,615	50,920	126,133	133,679	52,283	61,568	37,721	3,810	501,727		
1	57,883	47,285	133,995	175,875	66,003	65,620	26,750	4,200	577,610		
2	65,333	56,598	161,471	245,723	72,575	91,447	56,366	14,985	764,497		
3	60,080	65,378	155,010	221,070	87,959	78,316	49,635	7,625	725,072		
4	48,025	90,038	137,583	234,493	66,635	70,337	27,035	12,450	686,595		
5	31,577	67,640	145,435	210,825	64,623	61,687	32,303	9,235	623,323		
6	19,612	79,160	112,605	192,340	73,898	59,018	37,730	7,710	582,072		
7	18,947	67,103	118,970	199,484	63,463	56,597	41,845	17,300	583,708		
8	14,800	78,655	102,912	186,200	42,080	60,255	53,853	8,920	547,675		
9	9,355	78,010	123,682	167,750	37,778	81,309	56,200	13,310	567,393		
10	15,524	75,313	119,293	159,515	34,335	67,705	56,185	12,620	540,489		
11	5,374	61,795	106,655	170,015	46,115	65,985	41,147	9,744	506,831		
12	3,212	87,961	182,725	41,913	82,623	82,623	42,910	9,505	510,438		
13	7,112	96,358	160,078	33,700	63,198	63,198	50,240	8,435	451,265		
14	4,250	41,285	97,805	147,590	30,305	50,425	42,945	16,565	431,170		
15	3,825	29,185	95,930	136,450	29,710	57,482	35,499	16,290	404,371		
16	2,150	31,040	68,118	133,130	23,280	39,117	37,615	8,755	343,205		
17	2,075	24,580	55,860	95,555	16,805	34,923	37,060	5,110	271,968		
18	1,100	16,680	54,105	86,325	16,000	27,528	19,198	10,010	230,945		
19	3,480	20,545	52,788	103,715	22,048	33,495	32,852	5,610	274,532		
20	2,788	16,245	61,540	135,245	28,370	73,695	37,268	19,475	374,625		
21	1,075	29,945	62,385	125,705	15,305	51,433	32,617	11,620	330,085		
22	0,500	10,005	58,345	115,425	23,465	43,020	43,128	3,605	297,493		
23	1,000	7,840	64,200	103,529	19,015	39,695	50,904	12,710	298,892		
24	-	17,605	34,015	79,310	27,930	34,658	33,750	11,025	238,292		
25	4,990	5,000	39,940	97,190	14,555	30,262	34,180	8,620	234,737		
26	-	4,500	42,405	81,400	17,515	23,100	31,808	12,275	213,003		
27	-	5,000	20,500	58,875	12,305	36,945	20,562	6,365	160,552		
28	1,075	4,040	23,785	65,175	16,530	34,861	37,415	13,340	196,221		
29	-	1,000	32,593	91,855	21,270	39,775	43,447	28,340	258,279		
30	2,200	1,000	25,320	64,688	19,310	36,495	40,988	16,140	206,141		
31	-	5,305	30,575	58,960	13,610	28,135	43,398	18,166	198,149		
32	-	2,500	15,190	41,625	10,230	18,051	28,145	8,815	124,556		
33	-	2,100	19,965	35,230	16,710	23,800	27,742	9,680	135,227		
34	-	1,100	17,505	29,490	12,220	17,945	21,140	10,820	110,220		
35	-	-	6,755	17,515	13,305	15,443	27,171	9,461	89,650		
36	-	-	3,610	19,325	12,305	17,578	15,118	7,830	75,765		
37	-	1,000	5,050	8,700	7,305	9,560	10,280	6,315	48,210		
38	-	1,000	1,000	10,305	7,000	15,135	8,830	7,575	50,845		
39	-	1,000	3,740	3,610	3,000	8,015	12,435	3,915	35,715		
40+	-	-	1,305	7,605	3,000	16,760	10,160	4,540	43,370		
Total	422,956	1,189,128	2,722,389	4,593,296	1,235,758	1,822,994	1,425,572	432,821	13,844,914		

Note: Service personnel are presented on a regular FTE basis with full-time personnel employed beyond 200 days counted as 1.00, as opposed to an extended FTE basis where the FTE is determined by dividing each employee's number of days employed by 200 days.

**COUNTY BOARDS OF EDUCATION
AVERAGE CONTRACTED SALARIES - SERVICE PERSONNEL
(EXCLUDING RESA PERSONNEL)
2009-10 YEAR**

County	FTE	Average Salary
Barbour	120.000	\$ 24,042.60
Berkeley	889.800	25,623.18
Boone	233.500	27,195.55
Braxton	122.500	24,250.36
Brooke	167.500	26,432.43
Cabell	556.000	27,253.52
Calhoun	57.500	26,956.26
Clay	113.500	23,931.07
Doddridge	70.000	24,399.17
Fayette	341.000	25,679.76
Gilmer	48.500	24,616.60
Grant	96.000	24,073.55
Greenbrier	310.500	24,280.58
Hampshire	185.000	24,003.49
Hancock	198.500	26,959.20
Hardy	106.500	23,672.44
Harrison	525.750	26,397.32
Jackson	244.000	28,065.20
Jefferson	444.000	25,212.29
Kanawha	1,298.500	26,712.25
Lewis	143.500	24,763.81
Lincoln	185.000	24,833.14
Logan	324.000	25,671.72
Marion	419.000	25,406.36
Marshall	268.000	25,325.91
Mason	222.500	25,415.57
McDowell	216.000	26,653.05
Mercer	439.450	24,679.09
Mineral	237.500	26,654.91
Mingo	248.400	25,650.89
Monongalia	488.000	26,201.29
Monroe	119.010	23,570.53
Morgan	126.750	26,173.78
Nicholas	223.500	23,729.20
Ohio	240.500	28,443.70
Pendleton	64.000	25,783.91
Pleasants	79.000	27,919.68
Pocahontas	72.000	26,556.81
Preston	226.500	24,266.42
Putnam	416.500	27,326.53
Raleigh	530.500	25,624.83
Randolph	202.500	23,964.29
Ritchie	90.966	24,690.49
Roane	131.000	24,207.36
Summers	77.000	23,970.92
Taylor	121.000	24,547.59
Tucker	58.000	24,789.64
Tyler	80.500	25,094.20
Upshur	191.500	24,064.00
Wayne	384.040	23,618.24
Webster	80.500	23,897.93
Wetzel	149.000	26,144.51
Wirt	49.000	24,216.23
Wood	604.990	28,073.61
Wyoming	214.500	24,352.59
Total	13,852.656	\$ 25,761.62

OSF3

03/10/10

Avg Contracted Salary SP - All positions 10

**SERVICE PERSONNEL STATE MINIMUM MONTHLY PAY SCALE
STATE BASIC PAY SCALE WITHOUT EQUITY
FOR THE 2009-10 YEAR**

Years Exp.	PAY GRADE							
	A	B	C	D	E	F	G	H
0	1,577	1,598	1,639	1,691	1,743	1,805	1,836	1,908
1	1,609	1,630	1,671	1,723	1,775	1,837	1,868	1,940
2	1,641	1,662	1,703	1,755	1,807	1,869	1,900	1,972
3	1,673	1,694	1,735	1,787	1,839	1,901	1,932	2,004
4	1,705	1,726	1,767	1,819	1,871	1,933	1,964	2,037
5	1,737	1,758	1,799	1,851	1,903	1,965	1,996	2,069
6	1,769	1,790	1,832	1,883	1,935	1,997	2,028	2,101
7	1,802	1,822	1,864	1,915	1,967	2,029	2,060	2,133
8	1,834	1,854	1,896	1,947	1,999	2,061	2,092	2,165
9	1,866	1,886	1,928	1,980	2,031	2,093	2,124	2,197
10	1,898	1,919	1,960	2,012	2,063	2,126	2,157	2,229
11	1,930	1,951	1,992	2,044	2,095	2,158	2,189	2,261
12	1,962	1,983	2,024	2,076	2,128	2,190	2,221	2,293
13	1,994	2,015	2,056	2,108	2,160	2,222	2,253	2,325
14	2,026	2,047	2,088	2,140	2,192	2,254	2,285	2,357
15	2,058	2,079	2,120	2,172	2,224	2,286	2,317	2,389
16	2,090	2,111	2,152	2,204	2,256	2,318	2,349	2,422
17	2,122	2,143	2,185	2,236	2,288	2,350	2,381	2,454
18	2,154	2,175	2,217	2,268	2,320	2,382	2,413	2,486
19	2,187	2,207	2,249	2,300	2,352	2,414	2,445	2,518
20	2,219	2,239	2,281	2,333	2,384	2,446	2,477	2,550
21	2,251	2,271	2,313	2,365	2,416	2,478	2,509	2,582
22	2,283	2,304	2,345	2,397	2,448	2,511	2,542	2,614
23	2,315	2,336	2,377	2,429	2,481	2,543	2,574	2,646
24	2,347	2,368	2,409	2,461	2,513	2,575	2,606	2,678
25	2,379	2,400	2,441	2,493	2,545	2,607	2,638	2,710
26	2,411	2,432	2,473	2,525	2,577	2,639	2,670	2,742
27	2,443	2,464	2,505	2,557	2,609	2,671	2,702	2,774
28	2,475	2,496	2,537	2,589	2,641	2,703	2,734	2,807
29	2,507	2,528	2,570	2,621	2,673	2,735	2,766	2,839
30	2,540	2,560	2,602	2,653	2,705	2,767	2,798	2,871
31	2,572	2,592	2,634	2,685	2,737	2,799	2,830	2,903
32	2,604	2,624	2,666	2,718	2,769	2,831	2,862	2,935
33	2,636	2,656	2,698	2,750	2,801	2,863	2,895	2,967
34	2,668	2,689	2,730	2,782	2,833	2,896	2,927	2,999
35	2,700	2,721	2,762	2,814	2,866	2,928	2,959	3,031
36	2,732	2,753	2,794	2,846	2,898	2,960	2,991	3,063
37	2,764	2,785	2,826	2,878	2,930	2,992	3,023	3,095
38	2,796	2,817	2,858	2,910	2,962	3,024	3,055	3,127
39	2,828	2,849	2,890	2,942	2,994	3,056	3,087	3,159
40	2,860	2,881	2,922	2,974	3,026	3,088	3,119	3,192

Note: This schedule does not include the \$12/month supplemental pay for having a high school diploma or GED; the educational bonuses of: \$11/month for each of the following levels of college credit or comparable training in a trade or vocational school: 12, 24, 36, 48, 60, 72, 84, 96, 108, or 120 hours; \$40/month for an associate, bachelor's, master's, or doctorate degree; or \$11/month for each of the following: BA+15, MA+15, MA+30, MA+45, or MA+60: or the \$10/month shift differential pay.

OSF
04/14/09
State Salary Schedules 10

**SERVICE PERSONNEL STATE MINIMUM MONTHLY PAY SCALE
STATE EQUITY SUPPLEMENT PAY SCALE
FOR THE 2009-10 YEAR**

Years Exp.	PAY GRADE							
	A	B	C	D	E	F	G	H
0	115	115	115	115	115	115	115	115
1	115	115	115	115	115	115	115	115
2	115	115	115	115	115	115	115	115
3	115	115	115	115	115	115	115	115
4	115	115	115	115	115	115	115	115
5	115	115	115	115	115	115	115	115
6	115	115	115	115	115	115	115	115
7	115	115	115	115	115	115	115	115
8	115	115	115	115	115	115	115	115
9	115	115	115	115	115	115	115	115
10	115	115	115	115	115	115	115	115
11	115	115	115	115	115	115	115	115
12	115	115	115	115	115	115	115	115
13	115	115	115	115	115	115	115	115
14	115	115	115	115	115	115	115	115
15	115	115	115	115	115	115	115	115
16	115	115	115	115	115	115	115	115
17	115	115	115	115	115	115	115	115
18	115	115	115	115	115	115	115	115
19	115	115	115	115	115	115	115	115
20	115	115	115	115	115	115	115	115
21	115	115	115	115	115	115	115	115
22	115	115	115	115	115	115	115	115
23	115	115	115	115	115	115	115	115
24	115	115	115	115	115	115	115	115
25	115	115	115	115	115	115	115	115
26	115	115	115	115	115	115	115	115
27	115	115	115	115	115	115	115	115
28	115	115	115	115	115	115	115	115
29	115	115	115	115	115	115	115	115
30	115	115	115	115	115	115	115	115
31	115	115	115	115	115	115	115	115
32	115	115	115	115	115	115	115	115
33	115	115	115	115	115	115	115	115
34	115	115	115	115	115	115	115	115
35	115	115	115	115	115	115	115	115
36	115	115	115	115	115	115	115	115
37	115	115	115	115	115	115	115	115
38	115	115	115	115	115	115	115	115
39	115	115	115	115	115	115	115	115
40	115	115	115	115	115	115	115	115

Note: This schedule does not include the \$12/month supplemental pay for having a high school diploma or GED; the educational bonuses of: \$11/month for each of the following levels of college credit or comparable training in a trade or vocational school: 12, 24, 36, 48, 60, 72, 84, 96, 108, or 120 hours; \$40/month for an associate, bachelor's, master's, or doctorate degree; or \$11/month for each of the following: BA+15, MA+15, MA+30, MA+45, or MA+60; or the \$10/month shift differential pay.

OSF
04/14/09
State Salary Schedules 10

**SERVICE PERSONNEL STATE MINIMUM MONTHLY PAY SCALE
TOTAL MINIMUM REQUIRED PAY SCALE (BASIC PLUS EQUITY)
FOR THE 2009-10 YEAR**

Years Exp.	PAY GRADE							
	A	B	C	D	E	F	G	H
0	1,692	1,713	1,754	1,806	1,858	1,920	1,951	2,023
1	1,724	1,745	1,786	1,838	1,890	1,952	1,983	2,055
2	1,756	1,777	1,818	1,870	1,922	1,984	2,015	2,087
3	1,788	1,809	1,850	1,902	1,954	2,016	2,047	2,119
4	1,820	1,841	1,882	1,934	1,986	2,048	2,079	2,152
5	1,852	1,873	1,914	1,966	2,018	2,080	2,111	2,184
6	1,884	1,905	1,947	1,998	2,050	2,112	2,143	2,216
7	1,917	1,937	1,979	2,030	2,082	2,144	2,175	2,248
8	1,949	1,969	2,011	2,062	2,114	2,176	2,207	2,280
9	1,981	2,001	2,043	2,095	2,146	2,208	2,239	2,312
10	2,013	2,034	2,075	2,127	2,178	2,241	2,272	2,344
11	2,045	2,066	2,107	2,159	2,210	2,273	2,304	2,376
12	2,077	2,098	2,139	2,191	2,243	2,305	2,336	2,408
13	2,109	2,130	2,171	2,223	2,275	2,337	2,368	2,440
14	2,141	2,162	2,203	2,255	2,307	2,369	2,400	2,472
15	2,173	2,194	2,235	2,287	2,339	2,401	2,432	2,504
16	2,205	2,226	2,267	2,319	2,371	2,433	2,464	2,537
17	2,237	2,258	2,300	2,351	2,403	2,465	2,496	2,569
18	2,269	2,290	2,332	2,383	2,435	2,497	2,528	2,601
19	2,302	2,322	2,364	2,415	2,467	2,529	2,560	2,633
20	2,334	2,354	2,396	2,448	2,499	2,561	2,592	2,665
21	2,366	2,386	2,428	2,480	2,531	2,593	2,624	2,697
22	2,398	2,419	2,460	2,512	2,563	2,626	2,657	2,729
23	2,430	2,451	2,492	2,544	2,596	2,658	2,689	2,761
24	2,462	2,483	2,524	2,576	2,628	2,690	2,721	2,793
25	2,494	2,515	2,556	2,608	2,660	2,722	2,753	2,825
26	2,526	2,547	2,588	2,640	2,692	2,754	2,785	2,857
27	2,558	2,579	2,620	2,672	2,724	2,786	2,817	2,889
28	2,590	2,611	2,652	2,704	2,756	2,818	2,849	2,922
29	2,622	2,643	2,685	2,736	2,788	2,850	2,881	2,954
30	2,655	2,675	2,717	2,768	2,820	2,882	2,913	2,986
31	2,687	2,707	2,749	2,800	2,852	2,914	2,945	3,018
32	2,719	2,739	2,781	2,833	2,884	2,946	2,977	3,050
33	2,751	2,771	2,813	2,865	2,916	2,978	3,010	3,082
34	2,783	2,804	2,845	2,897	2,948	3,011	3,042	3,114
35	2,815	2,836	2,877	2,929	2,981	3,043	3,074	3,146
36	2,847	2,868	2,909	2,961	3,013	3,075	3,106	3,178
37	2,879	2,900	2,941	2,993	3,045	3,107	3,138	3,210
38	2,911	2,932	2,973	3,025	3,077	3,139	3,170	3,242
39	2,943	2,964	3,005	3,057	3,109	3,171	3,202	3,274
40	2,975	2,996	3,037	3,089	3,141	3,203	3,234	3,307

Note: This schedule does not include the \$12/month supplemental pay for having a high school diploma or GED; the educational bonuses of: \$11/month for each of the following levels of college credit or comparable training in a trade or vocational school: 12, 24, 36, 48, 60, 72, 84, 96, 108, or 120 hours; \$40/month for an associate, bachelor's, master's, or doctorate degree; or \$11/month for each of the following: BA+15, MA+15, MA+30, MA+45, or MA+60; or the \$10/month shift differential pay.

OSF
04/14/09
State Salary Schedules 10

**SUMMARY OF INCREASES TO SERVICE PERSONNEL
MONTHLY STATE BASIC PAY SCALE
1975-76 THROUGH 2009-10**

	Pay Grade								Exp. Incr.
	A	B	C	D	E	F	G	H	
Basic salary - 1975-76	350	370	410	460	510	570	600	670	10
Basic salary increases:									
1976-77	100	100	100	100	100	100	100	100	-
1977-78 (a)	25	25	25	25	25	25	25	25	-
1978-79	35	35	35	35	35	35	35	35	-
1979-80	28	28	28	28	28	28	28	28	3
1980-81	80	80	80	80	80	80	80	80	-
1981-82 (b)	56	56	56	56	56	56	56	56	5
1982-83	-	-	-	-	-	-	-	-	-
1983-84	-	-	-	-	-	-	-	-	-
1984-85 (c)	44	44	44	44	44	44	44	44	2
1985-86 (d)	44	44	44	44	44	44	44	44	-
1986-87	60	60	60	60	60	60	60	60	-
1987-88	-	-	-	-	-	-	-	-	-
1988-89	-	-	-	-	-	-	-	-	-
1989-90 (e)	27	27	27	27	27	27	27	27	2
1990-91	84	84	84	84	84	84	84	84	-
1991-92	17	17	17	17	17	17	17	17	-
1992-93	-	-	-	-	-	-	-	-	-
1993-94	-	-	-	-	-	-	-	-	-
1994-95 (f)	60	60	60	60	60	60	60	60	3
1995-96	-	-	-	-	-	-	-	-	-
1996-97	30	30	30	30	30	30	30	30	1
1997-98	-	-	-	-	-	-	-	-	-
1998-99 (g)	60	60	60	60	60	60	60	60	1
1999-2000 (h)	60	60	60	60	60	60	60	60	1
2000-01 (i)	60	60	60	60	60	60	60	60	1
2001-02 (j)	75	75	75	75	75	75	75	75	1
2002-03 (k)	71	71	71	71	71	71	71	71	1
2003-04	-	-	-	-	-	-	-	-	-
2004-05	-	-	-	-	-	-	-	-	-
2005-06	90	90	90	90	90	90	90	90	-
2006-07	-	-	-	-	-	-	-	-	-
2007-08 (m)	51	52	53	55	57	59	60	62	1
2008-09	70	70	70	70	70	70	70	70	-
2009-10	-	-	-	-	-	-	-	-	-
Total increases	1,227	1,228	1,229	1,231	1,233	1,235	1,236	1,238	22
Basic salary 2009-10	1,577	1,598	1,639	1,691	1,743	1,805	1,836	1,908	32
Annual experience increment:									
Years 1 - 40	32	32	32	32	32	32	32	32	(m)
Maximum years for increase	40	40	40	40	40	40	40	40	
Maximum incremental increase	1,280	1,283	1,283	1,283	1,283	1,283	1,283	1,284	
Basic salary with maximum experience increment 2009-10	2,860	2,881	2,922	2,974	3,026	3,088	3,119	3,192	

Notes:

- (a) Experience increment increase extended from 10 years to 13 years.
- (b) Experience increment increase extended from 13 years to 16 years.
- (c) Salary equity began in 1984-85; salaries shown do not include salary equity. Exp. Incr. extended from 16 years to 20 years.
- (d) Experience increment increase extended from 20 years to 25 years.
- (e) Experience increment increase extended from 25 years to 30 years. Additional \$10/month provided for a high school diploma or equivalent; increase in salary was provided in second half of year.
- (f) Additional \$10/month provided for 12 college hours or comparable training in a trade or vocational school and add'l \$10/month provided for working between 6pm and 5am, or which only \$5/month is funded by the State.
- (g) Experience increment increase extended from 30 years to 36 years.
- (h) Additional \$10/month pay for college or comparable training extended to 24, 36, and 48 hours.
- (i) Exp. increment increase extended from 36 to 40 years & add'l \$10/mo. pay for college or comparable trn. extended to 60 and 72 hrs.
- (j) In addition to the \$75/mo. increase in basic salaries, the experience increment was increased by \$1/mo, HS bonus increased to \$12/mo, and the \$10 educational bonuses were extended to 84, 96, 104, and 120 college hours or comparable training and to those with BA and MA degrees; all increases were made effective the 2nd quarter.
- (k) In addition to the \$71/month increase in basic salaries, educational bonuses were extended to include BA+15, MA+15, MA+30, MA+45, MA+60, and associate and doctorate degrees; bonuses for a college degree were increased to \$40/mo. for each degree level, and remaining bonuses were increased to \$11/mo.
- (l) Increase in basic salary made effective the first day of second quarter.
- (m) Basic salaries increased by 3.5% for the 2007-08 year, which also increased the experience increment by \$1.09 per month.

OSF - 12/09/09

Salary History

**SERVICE PERSONNEL JOB TITLES BY PAY GRADE
FOR THE 2009-10 YEAR**

Pay Grade A:

501 Aide I
675 Cook I
681 Custodian I

Pay Grade B:

502 Aide II
528 Clerk I
533 WVEIS Data Entry & Admin. Clerk
547 Key Punch Operator
557 Printing Operator
601 Handyman
676 Cook II
682 Custodian II
686 Groundsman
688 Watchman

Pay Grade C:

503 Aide III
529 Clerk II
531 Clerk - Maintenance
532 Clerk - Warehouse
574 Audiovisual Technician
597 General Maintenance
613 Lubrication Man
677 Cook III
683 Custodian III

Pay Grade D:

504 Aide IV
522 Accountant I
530 Clerk - Mail
535 Secretary I
541 Switchboard Operator/Recpt.
549 Draftsman
551 Graphic Artist
555 Inventory Supervisor
559 Printing Supervisor
599 Glazier
655 Bus Operator
659 Truck Driver
672 Cafeteria Manger
684 Custodian IV

Pay Grade E:

523 Accountant II
527 Braille or Sign Language Specialist
536 Secretary II
545 Computer Operator
578 Carpenter I

Pay Grade E (Continued):

605 Heating & Air Cond. Mechanic I
623 Mechanic Assistant
635 Painter
638 Plumber I
652 School Bus Supervisor
657 Heavy Equipment Operator

Pay Grade F:

511 Licensed Practical Nurse
515 Paraprofessional
519 Autism Mentor
524 Accountant III
526 Buyer
537 Secretary III
579 Carpenter II
583 Crew Leader
587 Electrician I
591 Electronic Technician I
617 Machinist
625 Mechanic
631 Office Equipment Repairman I
641 Roofing/Sheet Metal Mechanic
644 Welder

Pay Grade G:

525 Auditor
538 Executive Secretary
560 Accounts Payable Supervisor
561 Payroll Supervisor
576 Cabinet Maker
581 Chief Mechanic
588 Electrician II
592 Electronic Technician II
595 Foreman
606 Heating & Air Cond. Mechanic II
609 Locksmith
619 Mason
633 Office Equip. Repairman II
639 Plumber II
670 Food Services Supervisor
690 Sanitation Plant Operator

Pay Grade H:

521 Director/Coordinator of Services
546 Programmer
570 Supervisor of Maintenance
650 Supervisor of Transportation

Service Job Titles

PROGRAMS

WEST VIRGINIA DEPARTMENT OF EDUCATION
Charleston, West Virginia

OFFICE OF CHILD NUTRITION

The Department administers six United States Department of Agriculture (USDA) nutrition programs for children. They include the National School Lunch Program, School Breakfast Program, Child and Adult Care Food Program, Summer Food Service Program, Fresh Fruit and Vegetable Program and the Special Milk Program. In West Virginia more than 85 million dollars assist program sponsors to provide healthful, low-cost or free meals and snacks to children and functionally impaired adults in a variety of settings, including public and private schools, child care centers, residential institutions, shelters, family day care homes, summer camps and parks. In addition to providing nutritious meals and snacks, child nutrition programs promote lifelong healthful eating practices by integrating nutrition education, creating healthy learning environments and promoting nutrition in the community.

Child nutrition programs are intended to serve the nutrition needs of all children, regardless of family income. Since the inception of the National School Lunch Act more than 50 years ago, Congress has affirmed the importance of sound nutrition to the health and welfare of children. Nutrition programs enhance learning and quality of life. Children who are well nourished achieve and perform better than those who are not.

The School Lunch Program provides lunches to students in all public schools, 19 private schools and 30 institutions. The School Breakfast Program provides breakfasts in 710 public and 8 private schools and 30 institutions. The Child and Adult Care Food Program is sponsored by 275 child care agencies and subsidizes meals and snacks in 526 centers and 1,323 homes. Seven agencies sponsor nutrition programs in adult day care. The Summer Food Service Program provides meals to children in 489 summer programs (98 sponsors). The Special Milk Program provides milk to children in 9 camps and 9 private schools. Based on current records, West Virginia participants receive daily:

192,586	school lunches (57% free and reduced price)
85,927	school breakfasts (70% free and reduced price)
2,490	afterschool snacks
34,985	meals to children under child care (64% free and reduced price)
12,873	summer meals (100% free)
249	meals to functionally impaired adults
17,524	meals to children in family day care homes

The USDA Team Nutrition Training grants provide grant opportunities to schools, child care institutions, and in-service training to food service and teaching personnel.

The Fresh Fruit and Vegetable Program (FFVP) provides all children in participating schools with a variety of free fresh fruits and vegetables throughout the school day. It is an effective and creative way of introducing fresh fruits and vegetables as healthy snack options. The FFVP also encourages community partnerships to support the schools when they offer free fruit and vegetables to children during the school day. West Virginia will receive \$1,421,269 in funding to support this program in the 2010/11 school year.

Title I

Federally funded compensatory education programs in West Virginia operate under Public Law 107-110, known as the *No Child Left Behind Act of 2001* (NCLB). Title I is the largest single program of federal aid for elementary and secondary education. Therefore, Title I funding impacts the ability of districts to implement and accomplish the two missions of the United States Department of Education: enforcing equity and promoting excellence in education. The purpose of Title I is to ensure that all children have a fair, equal, and significant opportunity to obtain a high quality education and reach, at a minimum, proficiency on challenging State academic achievement standards and assessments.

The parts of Title I and the amount of funding allocated in 2009-2010 to various programs in the state are summarized in the chart below.

Title I			
Section of Title I	Purpose	Amount of Funding	Number of Districts/Schools
Part A	Provide assistance students in high poverty schools	\$86,262,430	55 districts
Part A - school imp. 4% set aside from SEA allocation	Provide assistance to Title I schools identified for improvement	\$6,167,200	18 districts 23 schools
Part C – Migrant	Provide educational assistance to migratory children to reduce educational disruptions and problems associated with repeated moves	\$78,046	1 district plus the salary costs for the migrant recruiter
Part D – Subpart 1 State agency programs for Neglected and Delinquent	Provide services and support to children in institutions for neglected and delinquent to assist these students in making a successful transition from institutionalization to further education or employment	\$721,925 non BOE centers	6 non BOE institutions receive services from this funding
Part D – Subpart 2 Local agency programs for Neglected and Delinquent	Provide support for the operation of local educational agency programs that involve collaboration with locally operated correctional facilities	\$371,949	5 districts

**Description of Approved IASA Title I Expenditures in West Virginia
For Instruction, By County, By Delivery Model 2009-2010**

County	Schoolwide Programs	Targeted Assistance Schools	Other Programs	Total Instruction
Barbour	\$ 934,119.00	\$ -	\$ 204,859.17	\$ 1,138,978.17
Berkeley	\$ 2,876,206.00	\$ -	\$ 18,728.28	\$ 2,894,934.28
Boone	\$ 1,302,094.00	\$ -	\$ 312,345.53	\$ 1,614,439.53
Braxton	\$ 1,096,169.00	\$ -	\$ 201,991.72	\$ 1,298,160.72
Brooke	\$ 657,954.00	\$ -	\$ 103,893.21	\$ 761,847.21
Cabell	\$ 4,496,882.00	\$ -	\$ 2,270,905.06	\$ 6,767,787.06
Calhoun	\$ 456,010.00	\$ -	\$ 1,400.00	\$ 457,410.00
Clay	\$ 994,615.00	\$ -	\$ 10,000.00	\$ 1,004,615.00
Doddridge	\$ 354,368.00	\$ -	\$ 40,835.00	\$ 395,203.00
Fayette	\$ 2,954,154.00	\$ -	\$ 8,000.00	\$ 2,962,154.00
Gilmer	\$ 342,085.00	\$ -	\$ 40,483.24	\$ 382,568.24
Grant	\$ 464,309.00	\$ -	\$ -	\$ 464,309.00
Greenbrier	\$ 1,473,360.00	\$ -	\$ 1,065,718.26	\$ 2,539,078.26
Hampshire	\$ 1,083,967.00	\$ -	\$ 53,600.00	\$ 1,137,567.00
Hancock	\$ 919,757.00	\$ -	\$ 41,000.00	\$ 960,757.00
Hardy	\$ 422,842.00	\$ -	\$ 4,228.42	\$ 427,070.42
Harrison	\$ 3,720,139.00	\$ -	\$ 178,496.89	\$ 3,898,635.89
Jackson	\$ 1,123,383.00	\$ -	\$ 141,140.33	\$ 1,264,523.33
Jefferson	\$ 925,242.00	\$ -	\$ 12,796.16	\$ 938,038.16
Kanawha	\$ 8,772,342.00	\$ -	\$ 10,763,127.46	\$ 19,535,469.46
Lewis	\$ 852,665.00	\$ -	\$ 442,526.15	\$ 1,295,191.15
Lincoln	\$ 1,659,299.00	\$ -	\$ -	\$ 1,659,299.00
Logan	\$ 2,636,483.00	\$ -	\$ 149,206.81	\$ 2,785,689.81
Marion	\$ 2,245,332.00	\$ -	\$ 1,635,653.88	\$ 3,880,985.88
Marshall	\$ 1,414,447.00	\$ -	\$ 24,943.04	\$ 1,439,390.04
Mason	\$ 1,197,099.00	\$ -	\$ 2,850.00	\$ 1,199,949.00
McDowell	\$ 3,823,824.00	\$ -	\$ 2,332,974.10	\$ 6,156,798.10
Mercer	\$ 3,570,751.00	\$ -	\$ 678,665.00	\$ 4,249,416.00
Mineral	\$ 1,109,160.00	\$ -	\$ 484,247.00	\$ 1,593,407.00
Mingo	\$ 2,428,735.00	\$ -	\$ -	\$ 2,428,735.00
Monongalia	\$ 1,921,571.00	\$ -	\$ 180,674.84	\$ 2,102,245.84
Monroe	\$ 478,875.00	\$ -	\$ 6,000.00	\$ 484,875.00
Morgan	\$ 424,106.00	\$ -	\$ 2,500.00	\$ 426,606.00
Nicholas	\$ 1,286,169.00	\$ -	\$ 343,586.07	\$ 1,629,755.07
Ohio	\$ 1,696,231.00	\$ -	\$ 210,951.76	\$ 1,907,182.76
Pendleton	\$ 194,627.00	\$ -	\$ 44,018.81	\$ 238,645.81
Pleasants	\$ 193,272.00	\$ -	\$ -	\$ 193,272.00
Pocahontas	\$ 338,010.00	\$ -	\$ 18,500.00	\$ 356,510.00
Preston	\$ 1,272,737.00	\$ -	\$ 129,547.00	\$ 1,402,284.00
Putnam	\$ 1,202,232.00	\$ -	\$ -	\$ 1,202,232.00
Raleigh	\$ 3,874,593.00	\$ -	\$ 40,000.00	\$ 3,914,593.00
Randolph	\$ 1,484,454.00	\$ -	\$ 396,609.85	\$ 1,881,063.85
Ritchie	\$ 442,651.00	\$ -	\$ 3,300.00	\$ 445,951.00
Roane	\$ 951,291.00	\$ -	\$ -	\$ 951,291.00
Summers	\$ 866,682.00	\$ -	\$ -	\$ 866,682.00
Taylor	\$ 742,877.00	\$ -	\$ -	\$ 742,877.00
Tucker	\$ 268,624.00	\$ -	\$ -	\$ 268,624.00
Tyler	\$ 456,648.00	\$ -	\$ 59,463.35	\$ 516,111.35
Upshur	\$ 1,356,195.00	\$ -	\$ 163,557.09	\$ 1,519,752.09
Wayne	\$ 2,399,187.00	\$ -	\$ 40,000.00	\$ 2,439,187.00
Webster	\$ 948,968.00	\$ -	\$ 307,547.66	\$ 1,256,515.66
Wetzel	\$ 758,649.00	\$ -	\$ 223,654.07	\$ 982,303.07
Wirt	\$ 327,263.00	\$ 123,484.68	\$ 2,000.00	\$ 452,747.68
Wood	\$ 4,309,201.00	\$ -	\$ 4,295,543.14	\$ 8,604,744.14
Wyoming	\$ 1,759,525.00	\$ -	\$ -	\$ 1,759,525.00
Totals	\$ 86,262,430.00	\$ 123,484.68	\$ 27,692,068.35	\$114,077,983.03

County	Administrative Salaries	Professional/Service Salaries	Fixed Charges	Supplies	Equipment
Barbour	\$ 91,549.05	\$ 448,421.67	\$ 160,700.57	\$ 3,283.74	\$ 45,506.00
Berkeley	\$ 177,244.00	\$1,101,721.33	\$ 529,157.38	\$ 65,825.43	\$ 11,029.99
Boone	\$ 124,637.42	\$ 479,735.63	\$ 215,955.76	\$ 95,087.21	\$ 10,005.74
Braxton	\$ 46,788.50	\$ 569,369.55	\$ 203,326.63	\$ 50,105.00	\$ 9,536.00
Brooke	\$ 17,245.58	\$ 227,314.20	\$ 136,571.25	\$ 60,629.46	\$ 151,794.16
Cabell	\$ 144,464.00	\$1,586,877.60	\$ 758,430.40	\$ 183,779.65	\$ 80,844.35
Calhoun	\$ 35,170.80	\$ 224,153.82	\$ 106,898.85	\$ 4,879.94	\$ 15,732.41
Clay	\$ 81,321.77	\$ 527,056.29	\$ 205,640.22	\$ 40,125.19	\$ -
Doddridge	\$ 20,497.00	\$ 165,003.89	\$ 77,463.00	\$ 1,464.46	\$ -
Fayette	\$ 148,000.00	\$1,705,780.30	\$ 618,835.89	\$ 35,318.51	\$ 19,376.34
Gilmer	\$ 75,616.03	\$ 145,413.00	\$ 61,612.74	\$ 1,660.04	\$ -
Grant	\$ 21,540.42	\$ 189,743.96	\$ 81,488.12	\$ 17,322.98	\$ -
Greenbrier	\$ 115,381.65	\$ 743,875.20	\$ 321,567.26	\$ 23,775.66	\$ 600.00
Hampshire	\$ 50,678.89	\$ 399,781.96	\$ 195,533.94	\$ 69,400.00	\$ 9,000.00
Hancock	\$ 43,046.00	\$ 278,321.00	\$ 127,575.36	\$ 32,467.76	\$ 10,383.89
Hardy	\$ 32,355.24	\$ 240,241.00	\$ 92,832.44	\$ 3,310.77	\$ -
Harrison	\$ 254,274.00	\$1,637,712.00	\$ 590,889.00	\$ 117,558.00	\$ -
Jackson	\$ 85,556.80	\$1,100,227.71	\$ 389,560.05	\$ 1,954.59	\$ 29,634.87
Jefferson	\$ 143,928.00	\$ 471,992.00	\$ 276,606.00	\$ 20,913.00	\$ -
Kanawha	\$ 192,330.03	\$5,386,723.33	\$ 2,242,243.87	\$ 121,666.96	\$ 102,755.73
Lewis	\$ 57,963.07	\$ 461,677.00	\$ 191,818.13	\$ 25,838.32	\$ 32,000.00
Lincoln	\$ 94,650.00	\$ 818,328.07	\$ 364,421.32	\$ 12,885.94	\$ -
Logan	\$ 192,500.00	\$1,324,078.48	\$ 621,893.66	\$ 167,185.96	\$ 761,000.00
Marion	\$ 108,500.00	\$1,729,876.84	\$ 793,481.45	\$ 206,452.82	\$ 48,301.00
Marshall	\$ 67,885.00	\$ -	\$ 263,621.14	\$ 49,725.61	\$ 4,577.55
Mason	\$ 67,522.00	\$ 18,574.00	\$ 25,033.00	\$ 29,000.00	\$ -
McDowell	\$ 242,952.88	\$1,658,091.00	\$ 1,025,423.72	\$ 81,433.27	\$ 4,172.00
Mercer	\$ 73,000.00	\$1,837,125.00	\$ 750,373.69	\$ 174,468.23	\$ 324,732.92
Mineral	\$ 48,107.00	\$ 585,089.00	\$ 206,283.14	\$ 1,232.00	\$ 650.00
Mingo	\$ 130,000.00	\$1,130,104.00	\$ 508,073.29	\$ 54,113.45	\$ 70,000.00
Monongalia	\$ 121,714.00	\$1,112,137.50	\$ 387,592.00	\$ 152,649.80	\$ 414,170.92
Monroe	\$ 38,022.65	\$ 184,511.70	\$ 76,775.61	\$ 800.00	\$ -
Morgan	\$ 8,511.34	\$ 181,935.50	\$ 57,139.94	\$ 38,505.45	\$ -
Nicholas	\$ 76,709.00	\$ 573,007.00	\$ 247,739.23	\$ 17,418.16	111,327.31
Ohio	\$ 97,657.10	\$ 1,116,087.00	\$ 419,413.00	-	\$ -
Pendleton	\$ 3,000.00	\$ 184,058.60	\$ 52,750.30	\$ 16,211.05	\$ 20,398.10
Pleasants	\$ -	\$ 106,045.77	\$ 34,350.00	\$ 6,769.74	\$ -
Pocahontas	\$ 22,432.00	\$ 304,198.99	\$ 90,494.00	\$ 25,558.39	127,512.20
Preston	\$ 77,484.48	\$ 603,762.29	\$ 238,617.52	\$ 16,729.58	\$ 16,295.00
Putnam	\$ 63,927.60	\$ 668,075.94	\$ 234,914.44	\$ 7,974.56	\$ 21,091.00
Raleigh	\$ 264,499.00	\$ 1,746,600.08	\$ 954,202.13	\$ 1,911.60	\$ -
Randolph	\$ 69,207.60	\$ 736,053.74	\$ 151,411.40	\$ 35,514.94	\$ 26,648.90
Ritchie	\$ 54,990.35	\$ 219,135.50	\$ 77,035.02	\$ 3,696.91	\$ 28,401.50
Roane	\$ -	\$ 593,840.07	\$ 274,575.00	\$ 9,500.00	\$ -
Summers	\$ 31,632.50	\$ 503,060.33	\$ 214,871.42	\$ 11,841.70	\$ -
Taylor	\$ 54,622.81	\$ 226,238.53	\$ 141,886.59	\$ 7,480.20	\$ -
Tucker	\$ 27,836.00	\$ 146,763.61	\$ 47,415.58	\$ 4,689.80	\$ -
Tyler	\$ 37,671.01	\$ 269,189.24	\$ 98,232.07	\$ 5,589.30	\$ 1,499.99
Upshur	\$ 109,581.08	\$ 713,263.53	\$ 242,617.13	\$ 30,394.87	\$ 12,000.00
Wayne	\$ 102,293.74	\$ 903,143.00	\$ 447,320.82	\$ 202,324.10	\$ 68,050.00
Webster	\$ 38,000.00	\$ 454,507.66	\$ 238,175.08	\$ 13,263.11	\$ -

County	Administrative Salaries	Professional/Service Salaries	Fixed Charges	Supplies	Equipment
Wetzel	\$ 63,425.75	\$ 170,463.83	\$ 72,762.62	\$ 186,288.00	\$ 71,060.74
Wirt	\$ 44,229.25	\$ 187,965.00	\$ 76,680.65	\$ 9,404.44	\$ 1,947.19
Wood	\$ 112,000.00	\$2,244,686.19	\$ 1,162,511.32	\$ 27,107.02	\$ 4,500.00
Wyoming	\$ 67,000.00	\$ 874,946.55	\$ 417,536.11	\$ 86,534.81	\$ 19,689.99
Totals	\$4,571,152.39	\$42,216,085.98	\$18,600,330.25	\$2,671,021.48	\$2,686,225.79

County	Teachers Number	FTE	Aides Number	FTE
Barbour	15	10	0	0
Berkeley	27	26.6	2	2
Boone	17	17	0	0
Braxton	12	12	0	0
Brooke	5	5	0	0
Cabell	35	35	2	2
Calhoun	5	5	0	0
Clay	11	11	0	0
Doddridge	6	5.25	1	0.25
Fayette	35	34.5	0	0
Gilmer	4	4	0	0
Grant	6	5	0	0
Greenbrier	16	15	1	0
Hampshire	11	11	1	1
Hancock	6	6	0	0
Hardy	5	5	0	0
Harrison	32	32	0	0
Jackson	21	21	0	0
Jefferson	9	9	0	0
Kanawha	102	101.5	0	0
Lewis	9	8.5	0	0
Lincoln	18	18	0	0
Logan	32	30.55	0	0
Marion	28	28	0	0
Marshall	13	13	0	0
Mason	11	11	0	0
McDowell	20	20	8	8
Mercer	46	44.5	9	9
Mineral	10	7.1	0	0
Mingo	22	22	3	3
Monongalia	19	18.5	0	0
Monroe	6	6	0	0
Morgan	6	5.5	0	0
Nicholas	12	11	0	0
Ohio	19	19	0	0
Pendleton	3	3	0	0
Pleasants	2	2	0	0
Pocahontas	5	4.5	1	1
Preston	12	12	0	0
Putnam	18	17.5	0	0
Raleigh	47	43.5	0	0
Randolph	21	20.5	2	2
Ritchie	3	2.5	0	0
Roane	14	13.5	3	3
Summers	8	8	0	0
Taylor	9	8.5	0	0
Tucker	4	3.5	1	1
Tyler	6	6	0	0
Upshur	13	13	0	0
Wayne	24	24	5	5
Webster	11	10.5	4	4
Wetzel	5	5	4	0
Wirt	5	5	0	0
Wood	49	48.5	1	1
Wyoming	27	27	0	0
Totals	937	911.5	48	42.25

Title II, Part A

Preparing, Training, and Recruiting Quality Teachers and Principals

Title II, Preparing, Training, and Recruiting High Quality Teachers and Principals was reauthorized under the Elementary and Secondary Education Act of 1965, as amended by the No Child Left Behind Act of 2002. The purpose of this program is to provide grants to State Educational Agencies, Local Educational Agencies, State agencies for higher education, and eligible partnerships in order to increase student academic achievement through strategies such as improving teacher and principal quality and increasing the number of highly qualified teachers in classrooms and highly qualified principals and assistant principals in schools. Title II also has the responsibility of holding Local Educational Agencies and schools accountable for improvements in student academic achievement. The West Virginia Department of Education's Office of Title II, School & School System Improvement administers the elementary and secondary education portion of the Title II grant.

West Virginia received \$22,769,351 as the FY 2010 allocation; of that amount \$21,985,935 was allocated for local county school systems. The West Virginia Department of Education was allocated \$783,416 for state level training and administration. Of the funds received and administered by the West Virginia Department of Education, less than one half of one percent of the funds retained at the state level are used for statewide administration of the program.

A total of \$21,985,935 of the state allocation flowed to the 55 county school systems. Each county's allocation was based upon the total public and private non-profit school enrollments and in proportion to the county's allocation received under part A of Title I.

Examples of the variety of programs and services provided in school year 2009-2010 include:

- Participation in a variety of research based professional development activities for teachers targeted to individual county needs, including Title I and special education teachers, in collaboration and coordination with other funding sources such as Title I.
- Hiring of qualified teachers to reduce class size especially in lower grades.
- Participation by RESA model Arts Teams in receiving intensive professional in three strands: Critical Thinking and Problem Solving Skills, Strengthening of Arts Programs' Relationships with Parents and Community, and Strengthening of Instructional Management Skills. All three strands will be applied to the core content areas of dance, music, theatre, and visual art. The trainers will be arts teachers whose programs are outstanding MODEL programs in their respective content areas. These teachers will become trainers to develop model programs for arts

teams in each of the eight RESAs in the second year. The third year the arts teams in each RESA will continue professional development for teachers of the arts for all schools in each RESA.

- Continued development of high quality classrooms for pre-kindergarten and kindergarten children because of the growth in this population of professionals as a result of W.Va. Code §18-5-44. This development includes: three week-long college courses specifically designed for WV Pre-k teachers and assistants, an instructional coach to help move professional development for WV Pre-k teachers from awareness to implementation, and the development of a cadre of kindergarten teachers to address issues specific to kindergarten teaching and children.
- Provision of professional development for social studies teachers in civics and personal finance as a 21st Century Skill.
- Development of laboratory modules to provide secondary school science teachers with professional development, curriculum materials, and the necessary technology to conduct rigorous laboratory units in the sciences. These modules will be based on WV CSO's, aligned with state standards and assessments, and designed with consideration of the needs of higher education. The modules will be developed using the concepts set forth by the Partnership for 21st Century Skills and will also be designed to improve student performance on state and college assessments. The laboratory units will include activities on a variety of topics such as digital photography, precise site location using hand-held GPS units, computer-based mapping and software packages, and various other chemical and physical science topics. Teachers who participate in the development of the modules will return for a follow-up session each year to refine and develop their skills and knowledge and to provide professional development to additional teachers.
- Provision of *West Virginia Writes* as a state-wide plan for the professional development of RESAs, administrators and teachers in the core areas of process writing, writing rubrics/assessments, content area writing, on-demand writing, teaching writing with technology and the role of writing in higher education.
- Development of a state team of experts for Classroom Assessment for Learning that will help lead the development of professional learning communities for this 21st century system of assessment for the classrooms of West Virginia.

Math Science Partnership Program
Title II, Part B

The Math Science Partnership (MSP) program was created under the No Child Left Behind Act of 2001 (NCLB), which reauthorized the Elementary and Secondary Education Act (ESEA). The goal of the MSP program is to improve academic achievements of elementary and secondary students in mathematics and science by increasing instructional quality. In achieving this aim, the MSP must provide a minimum of a two-week summer institute for teachers with at least four follow-up days of support for teachers' learning during the school year.

The MSP is a competitive grant program awarded to partnerships between eligible county school systems and institutions of higher education. The partnerships must contain these: museums, professional societies, research laboratories, and business and industry organizations may participate. Successful partnerships are ones in which all the participants are willing to take risks. Each partner must have a stake in the outcome, something to gain if the partnership is successful and something to lose if it is not.

The grants are approximately \$189,000 per year for three years. Five projects completed the their funding cycle during FY 2010. For the FY 2011, the West Virginia Department of Education will award two new grants. The FY 2011 allocation to West Virginia is \$1,058,763.

Title III

Authorized under Public Law 107-110, *No Child Left Behind*, Title III subgrants support the efforts of school districts to assist limited English proficient (LEP) students to learn English and meet challenging State Content Standards and Objectives. Districts are eligible to apply for two types of Title III funding. Formula-based Title III grants are awarded based on the number of LEP students enrolled. Immigrant grants are awarded based on significant increases in the number of immigrant LEP students. Title III funds must be used to carry out activities that use approaches and methodologies that are based on scientifically-based research on teaching LEP children and immigrant children. The funds should be used for developing and implementing new language instruction educational programs; expanding or enhancing existing language instruction educational programs; implementing school-wide or system-wide programs designed to restructure, reform, and upgrade all programs, activities, and operations related to the education of limited English proficient students. The following school systems/consortia received Title III funding in FY10.

County/Consortia	Type of Funding	Amount of Funding
Berkeley	Title III Formula	\$115,070.00
Cabell	Title III Formula	\$42,180.00
Greenbrier	Title III Formula	\$10,730.00
Hardy	Title III Formula	\$21,830.00
Harrison	Title III Formula	\$26,270.00
Jefferson	Title III Formula	\$109,150.00
Kanawha	Title III Formula	\$86,950.00
Monongalia	Title III Formula	\$93,610.00
Raleigh	Title III Formula	\$11,840.00
Wood	Title III Formula	\$15,170.00
Putnam/Jackson Consortium	Title III Formula	\$18,130.00
RESA IV Consortium	Title III Formula	\$25,530.00
RESA VI Consortium	Title III Formula	\$27,380.00
	Immigrant	
TOTAL		\$603,840.00

Title IV Part A

21st Century Community Learning Center Grant Program

The West Virginia Department of Education serves as the administrator for the federally funded 21st Century Learning Center (21st CCLC) grant program. The purpose of the 21st CCLC is to establish and expand community learning centers that will assist learning and development for school age children and their families during out-of-school time. The program is authorized under Title IV, Part B of the Elementary and Secondary Act, H.R.-1. Allocations for each state are based upon the state's student enrollment and Title I participation. Since 2004, West Virginia's 21st Century CCLC programs have served 102,917 children in 152 centers through the provision of meaningful academic enrichment opportunities.

The 21st Century Community Learning Center Program name, county or area served, yearly amount of funding and current year of the five-year cycle of funding is indicated in the chart below:

County/Area Served	Project Name	Current year of 5-year cycle*	Current Year of Funding 10
RESA IV(Braxton, Fayette, Greenbrier, Pocahontas, Webster)	Block 21 (School Programs to Accelerate Curricular Excellence) Expansion	Fifth	\$212,150.25
RESA VII (Barbour, Upshur , Harrison)	Project ISAAC (Increasing Student Achievement Advancing Communities) (Expansion 2)	Fifth	\$316,482.75
Wayne County	Playmates Preschool and Child Care Centers	Fifth	\$212,150.25
Monroe County	Our Own Back Yard	Fourth	\$100,000.00
RESA VII (Berkley Jefferson)	Project ISAAC (Increasing Student Achievement Advancing Communities)	Fourth	\$200,000.00

County/Area Served	Project Name	Current year of 5-year cycle*	Current Year of Funding 10
Jackson County	PATCH 21 st CCLC		\$241,272.00
RESA VII(Barbour, Doddridge , Marion)	Project ISSAC	Third	\$350,000.00
Monroe County	Our Own Back Yard	Third	\$250,000.00
Marion County	Marion County 21 st CCLC	Third	\$250,000.00
Roane County	PATCH 21 st CCLC	Third	\$250,000.00
Wayne County	Playmates Preschool and Childcare	Third	\$250,000.00
Mercer County	Mercer County CCLC	Third	\$200,000.00
Clay County	Clay County 21 st CCLC	Third	\$200,000.00
Jackson County	PATCH 21 st CCLC	Third	\$200,000.00
Cabell/ Wayne County	Boy's and Girls Club of Huntington	Third	\$200,000.00
RESA IV Fayette, Greenbrier, Nicholas,	Sound Track	Third	\$274,400.36
McDowell County	DREAMS(Developing Realistic Expectations Among McDowell Students)	Third	\$200,000.00
Barbour	KidREACH	Second	\$200,000.00
Wayne County	Playmates Preschool and Child Care Centers	Second	\$225,000.00
Monongalia	Kaleidoscope 21st CCLC	Second	\$200,000.00
RESA IV(Braxton Fayette, Webster)	Connections	Second	\$250,000.00
Partnership of African American Churches	Communities Closing the Gap	Second	\$200,000.00

County/Area Served	Project Name	Current year of 5-year cycle*	Current Year of Funding 10
Preston	Preston Co. Community Learning Centers	Second	\$200,000.00
Ritchie County	S.T.A.R.S (Strategies To Accelerate Ritchie Students)	Second	\$200,000.00
RESA VII(Lewis, Preston, Harrison)	Project ISSAC	Second	\$200,000.00
Clay County	Clay County 21st CLC Expansion Project	Second	\$163,113.00
Fayette County	New River Health Association, Inc./Accent Education	Second	\$150,749.54
Kanawha- The Bob Burdette Center	Charleston Extended Learning Centers	Second	\$200,000.00
Ohio County	Anchor II	Second	\$200,000.00
Lincoln County	Lincoln Co. Schools 21st Century Community Learning Center	Second	\$200,000.00
Calhoun County	Heads Up	Second	\$150,000.00
McDowell County	DREAMS 2 (Developing Realistic Expectations Among McDowell Students)	Second	\$172,920.00
Step by Step (Lincoln, Logan)	WV Dreamers Afterschool Program (21st CCLC)	Second	\$180,000.00
RESA I(Raleigh, Summers)	Project Challenge	Second	\$200,000.00
Nicholas	Project Connect	Second	\$150,000.00

Rural and Low Income School Program
Title VI, Part B, Subpart 2

The Rural and Low-Income School Program is a new program as of the passing of the No Child Left Behind Amendments to ESEA in 2001. The program targets rural school districts that serve high numbers of poor students. Not all West Virginia counties are eligible for the program, and the number of eligible counties varies from year to year. County school systems are eligible if they have 20 percent or more of the children aged 5 through 17 served by the system from families with incomes below the poverty line and all the schools served by the county are rural as defined by this program. For FY 2010 the allocation for the Rural and Low-Income School Program was \$2,923,975. Of this amount, \$2,779,677 was allocated to county school systems and \$144,298 was retained by the state for administration, monitoring, and technical assistance. The twenty-eight (28) county school systems eligible for Rural and Low-Income School program funding have a great amount of flexibility in how to use the funds from this grant. The funding for this program can be used for any expense that would be eligible for funding in any of the following programs:

1. Title I, Part A - Improving academic achievement of the disadvantaged.
2. Title II, Part A - Recruitment, retention and professional development for teachers and principals.
3. Title II, Part D – Educational technology.
4. Title III - Language instruction for limited English proficient students.
5. Title IV – Providing for safe and drug free schools and communities.
6. Parental Involvement in any program.

Once a county school system is identified for improvement they may only continue to use the funds in this program if it is spent for school improvement activities targeted at the reason they were identified.

The largest portion of this grant in eligible counties in West Virginia supports teacher professional development activities and provides for integration of technology into the curriculum.

SECOND MONTH REPORT ELIGIBLE COUNT

The eligible count of students with exceptionalities is reported to the Office of School Finance for computation of adjusted enrollment in the Public School Support Program. Prior to 2008-2009, students with exceptionalities receiving special education services by the end of the second school month received additional weighting in the school-aid formula to yield the county's adjusted enrollment. Beginning in FY09, legislative revisions to the Public School Support Program based funding primarily on net enrollment. For the first five years, however, districts projected to receive less funding under the new computation continue to receive an adjustment based on the amount they would have received using the adjusted enrollment calculation.

The total number of exceptional students at the end of the second school month for the 2009-2010 school year was 49,827. The eligible count for the 2008-2009 school year was 50,500. Therefore, FY10 shows a decrease of 673 students.

**Second Month Count of Students with Exceptionalities
2009-2010**

Barbour	439	Mingo	695
Berkeley	3,011	Monongalia	2,017
Boone	907	Monroe	331
Braxton	432	Morgan	360
Brooke	771	McDowell	663
Cabell	1,981	Nicholas	820
Calhoun	163	Ohio	1,036
Clay	352	Pendleton	238
Doddridge	254	Pleasants	236
Fayette	953	Pocahontas	215
Gilmer	154	Preston	967
Grant	407	Putnam	1,748
Greenbrier	998	Raleigh	1,943
Hampshire	646	Randolph	818
Hancock	869	Ritchie	304
Hardy	332	Roane	441
Harrison	2,254	Summers	212
Jackson	883	Taylor	396
Jefferson	1,271	Tucker	180
Kanawha	4,982	Tyler	332
Lewis	551	Upshur	719
Lincoln	746	Wayne	1,441
Logan	809	Webster	214
Marion	1,305	Wetzel	552
Marshall	1,007	Wirt	131
Mason	819	Wood	2,392
Mercer	1,402	Wyoming	882
Mineral	846	State Total	49,827

MEDICAID

For more than 15 years, the West Virginia Department of Education (WVDE) has been authorized to seek federal Medicaid reimbursement for health-related services that are part of a student's Individualized Education Program (IEP). The reimbursable services are speech, physical and occupational therapies, psychological services, audiology and private duty nursing services provided to eligible students.

In January 2000, in collaboration with the Department of Health and Human Resources, the WVDE included six (6) additional services to be reimbursed by Medicaid. Those services are initial/reevaluation treatment planning, annual/update treatment planning, care coordination, personal care services and specialized transportation vehicles and aides. The rates for these services are calculated based on school districts' costs.

The WVDE developed a system for billing these services directly with the eight (8) Regional Education Service Agencies (RESAs) acting as the billing/processing agents for the Local Education Agencies (LEAs). The billing system was incorporated into the West Virginia Education Information System (WVEIS), establishing an electronic billing record. Data may be entered from either the LEA or RESA level.

As a result, \$48.3 million in federal Medicaid reimbursement was received by LEAs statewide in FY 2010. West Virginia returns 100 percent of its federal Medicaid reimbursement to the LEAs and RESAs using state and local education funds to certify the State's match.

PRESCHOOL CHILDREN WITH DISABILITIES

In the 2009-2010 school year, special education and related services were provided to 5754 children ages 3-5, including children identified as preschool special needs, speech-language impaired and other disabilities as per available information. These services promoted their skills in all developmental areas. In addition, each eligible family is involved in an active partnership with education to enhance the child's development and promote family empowerment.

SERVICES TO STUDENTS WITH DEAFBLINDNESS

One hundred twenty (120) children, birth through 21, have been identified as deafblind in West Virginia based on the DeafBlind Census, conducted annually by the WVDE. These are children with hearing and visual impairments occurring together, the combination of which causes such severe communication and other developmental and educational challenges that they cannot be appropriately educated in special education programs solely for children with deafness or blindness. Federal funds appropriated under this program are to improve special education and related services for these children. The project currently serves the one hundred twenty (120) children who are deafblind and their families, teachers and service providers throughout the state.

WV SCHOOL TRANSPORTATION

The Office of School Transportation acts as the agency for the Department of Education in providing safe and efficient school transportation for all public students in West Virginia. School bus transportation is the safest way to transport a child to school. Fatal crashes involving occupants are extremely rare events, even though school buses serve daily in every community. Every school day across West Virginia, 3795 buses transport 236,000 students. Last year West Virginia did not have a single child killed as a school bus occupant while traveling over 42,000,000 miles. The Office of School Transportation provides the following services to the county school systems:

- Provide certification, training, inspections, coordination, and technical assistance to assure the performance of safe, efficient transportation of all students riding a school bus to and from school.
- Ensure all school bus operators in West Virginia are properly licensed, certified, trained, and are physically fit to perform their duties safely and effectively.
- Ensure all public school buses in West Virginia are in the best possible mechanical condition by regularly scheduled inspections.
- Promote school bus safety programs.

The minimum requirement of forty hours of classroom and 12 hours of skills training for all school bus operator applicants, required annual refresher training of twelve hours, written examinations, annual physical examinations, criminal records checks, motor vehicle records checks, and pre-employment and random drug and alcohol screening combine to make West Virginia among the leaders in our nation in the amount of training and testing required for school bus operators.

Each summer, more than 400 people attend the school transportation conference. During the conference many timely and informative workshops and in-service sessions are held for county transportation administrators and maintenance mechanics.

The Office of School Transportation is responsible for regulating the minimum requirements for design and equipment of school buses. West Virginia leads the way in school bus safety and school bus design and construction. School transportation officials from around the United States recognize and respect the performance, efficiency, and safety record of school transportation in West Virginia.

OFFICE OF SCHOOL FACILITIES

The Office of School Facilities (OSFac) provides facilities oversight and technical assistance for West Virginia's county school systems in the following ways: 1) indoor air quality investigation and remediation, 2) building automation design and operational technical support, 3) Heating Ventilating technical support, 4) Federal and State regulatory implementation and evaluations, 5) energy management and utilization, 6) plant operations and maintenance, 7) Comprehensive Educational Facilities Plans (CEFPs) development and administration, 9) accountability and responsibility for the West Virginia State Board of Education Policies' 6200, 6201, 6202, 6203, and 6204, and 10) facilities reviews for all School Building Authority financed schools. The professional staff supports and enhances a safe and comfortable environment for children to learn and play. The Executive Director is the State Superintendent's liaison with Department of Military Affairs and Public Safety, Homeland Security, and the State Office of Emergency Management.

In March 1999, the West Virginia Legislature enacted legislation that provides for investigation and resolution of indoor air quality issues in public schools. The OSFac in conjunction with the West Virginia Department of Health and Human Resources, Radiation, Toxics and Indoor Air Division developed a policy for investigating complaints of compromised indoor air quality in school facilities.

The progress made in improving school facilities in recent years has drawn national recognition defining the West Virginia Department of Education's, Office of School Facilities, as a world-class leader in enhancing the indoor learning environment.

The OSFac has saved the county systems millions of dollars in operational costs since its inception. The cost savings include technical assistance in energy, maintenance, indoor air quality, engineering, construction and design, risk management, and training that we provide at no expense to the county school systems.

Our staff members include a Certified Indoor Environmentalist, a Certified Mold Environmentalist, a mechanical engineer, and a Registered Educational Facilities Manager (REFP).

Additionally, staff members are members of the Association of Physical Plant Administrators, the American Society of Heating, Refrigeration and Air Conditioning Engineers (ASHRAE), the Construction Owners Association of America, and the Indoor Air Quality Association of America.

**WEST VIRGINIA
TECHNICAL AND ADULT EDUCATION SUMMARY
2008-2009**

ENROLLMENT:

Secondary, Occupational	52,304
Secondary, Family & Consumer Sciences	13,502
Secondary, Technology Education	14,105
Secondary, Applied Academics and Prevocational	17,105
Sub Total	97,016
Postsecondary, College	21,827
Postsecondary, Non-College	1,622
Sub Total	23,449
Adult Supplemental, Occupational	133,031
Adult Supplemental, Public Service	46,139
Sub Total	179,170
Adult Basic Education (ABE)	32,996
Sub Total	32,996
Grand Total.....	332,631

NUMBER OF PROGRAMS:

Secondary, Occupational.....	1018
Secondary, All Other.....	3463
Postsecondary, College	148
Postsecondary, Non-College	88
Adult Supplemental and Public Service Training	3,526
Total.....	5,126

NUMBER OF FACILITIES:

Multi-County Centers	7
County Vocational Centers, Five or More Programs	23
High Schools, Five or More Programs	25
Special Schools, Five or More Programs	3
Colleges, Five or More Programs	14
Colleges, Less than Five Programs	2
All Other	194
Total.....	268

ADULT BASIC EDUCATION ENROLLMENT AND FUNDING

Fiscal Year	Enrollment	Federal Amount	State Amount
1979	11,511	\$ 995,582	\$ 700,000
1980	14,628	\$ 1,089,943	\$ 700,000
1981	14,663	\$ 1,089,943	\$ 700,000
1982	14,529	\$ 1,089,973	\$ 768,994
1983	16,588	\$ 951,177	\$ 825,635
1984	15,618	\$ 1,050,749	\$ 950,784
1985	17,795	\$ 1,102,444	\$ 1,248,000
1986	17,746	\$ 1,150,132	\$ 1,248,000
1987	19,634	\$ 11,006,810	\$ 1,282,400
1988	20,738	\$ 1,209,933	\$ 1,282,400
1989	20,019	\$ 1,307,994	\$ 1,282,400
1990	21,186	\$ 15,432,917	\$ 1,226,500
1991	23,077	\$ 1,756,166	\$ 1,707,000
1992	26,133	\$ 2,206,982	\$ 1,789,000
1993	25,866	\$ 2,566,069	\$ 1,901,127
1994	24,028	\$ 2,493,878	\$ 1,899,450
1995	26,232	\$ 2,493,882	\$ 2,052,666
1996	24,712	\$ 2,472,850	\$ 2,085,524
1997	24,892	\$ 2,427,162	\$ 2,360,207
1998	25,556	\$ 3,292,467	\$ 2,425,358
1999	23,751	\$ 339,039	\$ 2,600,500
2000	29,817	\$ 3,597,698	\$ 2,743,941
2001	28,184	\$ 4,088,283	\$ 2,887,437
2002	32,109	\$ 4,507,025	\$ 3,076,481
2003	29,228	\$ 4,516,055	\$ 3,276,216
2004	30,982	\$ 4,412,561	\$ 2,987,191
2005	29,942	\$ 3,977,305	\$ 3,113,039
2006	28,940	\$ 3,879,445	\$ 3,229,263
2007	30,132	\$ 3,842,198	\$ 3,523,655
2008	30,552	\$ 3,842,198	\$ 3,693,116
2009	32,996	\$ 3,837,905	\$ 3,895,435

**TECHNICAL AND ADULT EDUCATION
PLACEMENT OF GRADUATES AVAILABLE FOR EMPLOYMENT***

YEAR	LEVEL	PERCENTAGE
1983	SECONDARY	76.2
	ADULT	87.0
1984	SECONDARY	79.6
	ADULT	88.7
1985	SECONDARY	81.3
	ADULT	87.1
1986	SECONDARY	84.3
	ADULT	93.5
1987	SECONDARY	86.7
	ADULT	88.9
1988	SECONDARY	88.3
	ADULT	93.0
1989	SECONDARY	85.6
	ADULT	88.9
1990	(DATA NOT AVAILABLE)	(DATA NOT AVAILABLE)
1991	SECONDARY	88.0
	ADULT	95.8
1992	SECONDARY	89.4
	ADULT	97.9
1993	SECONDARY	87.6
	ADULT	92.3
1994	SECONDARY	77.9
	ADULT	93.4
1995	SECONDARY	87.5
	ADULT	92.0
1996	SECONDARY and ADULT	93.7
1997	SECONDARY and ADULT	86.4
1998	SECONDARY and ADULT	90.5
1999	SECONDARY and ADULT	87.9
2000	SECONDARY and ADULT	88.8
2001	SECONDARY and ADULT	91.2
2002	SECONDARY and ADULT	82.8
2003	SECONDARY and ADULT	73.0
2004	SECONDARY and ADULT	91.7
2005	SECONDARY and ADULT	92.8
2006	SECONDARY and ADULT	89.7
2007	SECONDARY and ADULT	90.8
2008	SECONDARY AND ADULT	94.7
2009	SECONDARY AND ADULT	92.7

*Placement as indicated by this data shows the percentage of students who were actively seeking employment who found a job.

**TECHNICAL AND ADULT EDUCATION
STATE APPROPRIATIONS**

FISCAL YEAR	STATE APPROPRIATION
1980-1981	10,017,604
1981-1982	9,685,509
1982-1983	10,542,529
1983-1984	10,832,669
1984-1985	11,080,000
1985-1986	11,608,009
1986-1987	11,509,945
1987-1988	10,934,945
1988-1989	11,667,147
1989-1990	11,559,064
1990-1991	11,501,167
1991-1992	11,864,632
1992-1993	11,798,561
1993-1994	11,734,183
1994-1995	11,739,925
1995-1996	11,791,881
1996-1997	12,689,369
1997-1998	13,708,374
1998-1999	13,730,996
1999-2000	13,976,812
2000-2001	14,053,724
2001-2002	15,721,333
2002-2003	16,358,734
2003-2004	15,554,960
2004-2005	16,226,673
2005-2006	17,532,365
2006-2007	18,323,877
2007-2008	19,181,878
2008-2009	20,389,215
2009-2010	20,404,926

DISTRIBUTION OF TECHNICAL AND ADULT EDUCATION FACILITIES

Technical and Adult Education programs, utilizing over 300 schools, are available to students in every county in the state. Students at secondary, post-secondary and adult levels are within easy accessibility of career/technical training with a minimum of inconvenience.

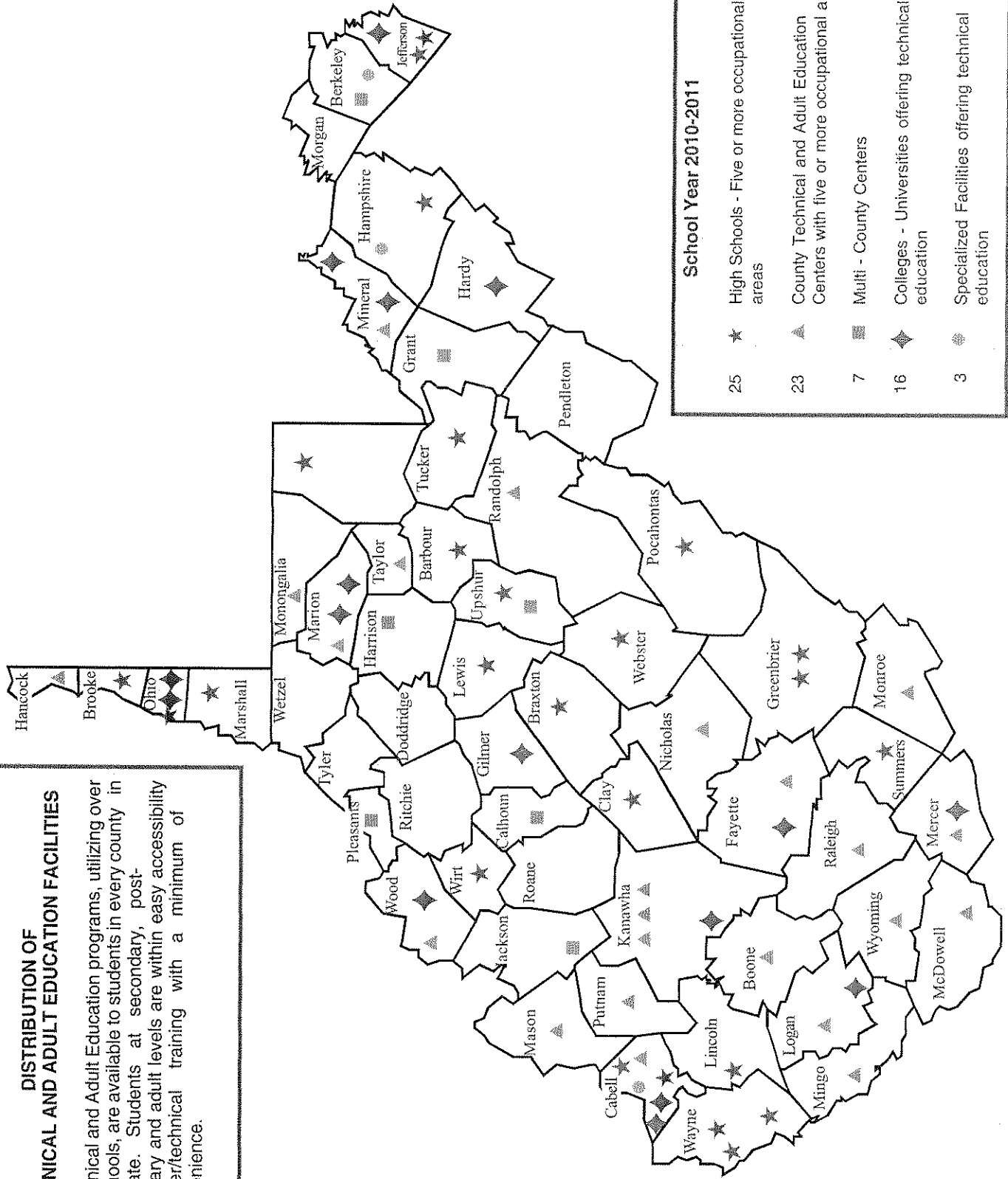

**West Virginia Department of Education
High Schools That Work Sites
 and
21st Century High Schools That Work Sites
 and
*Technical Centers That Work Sites***

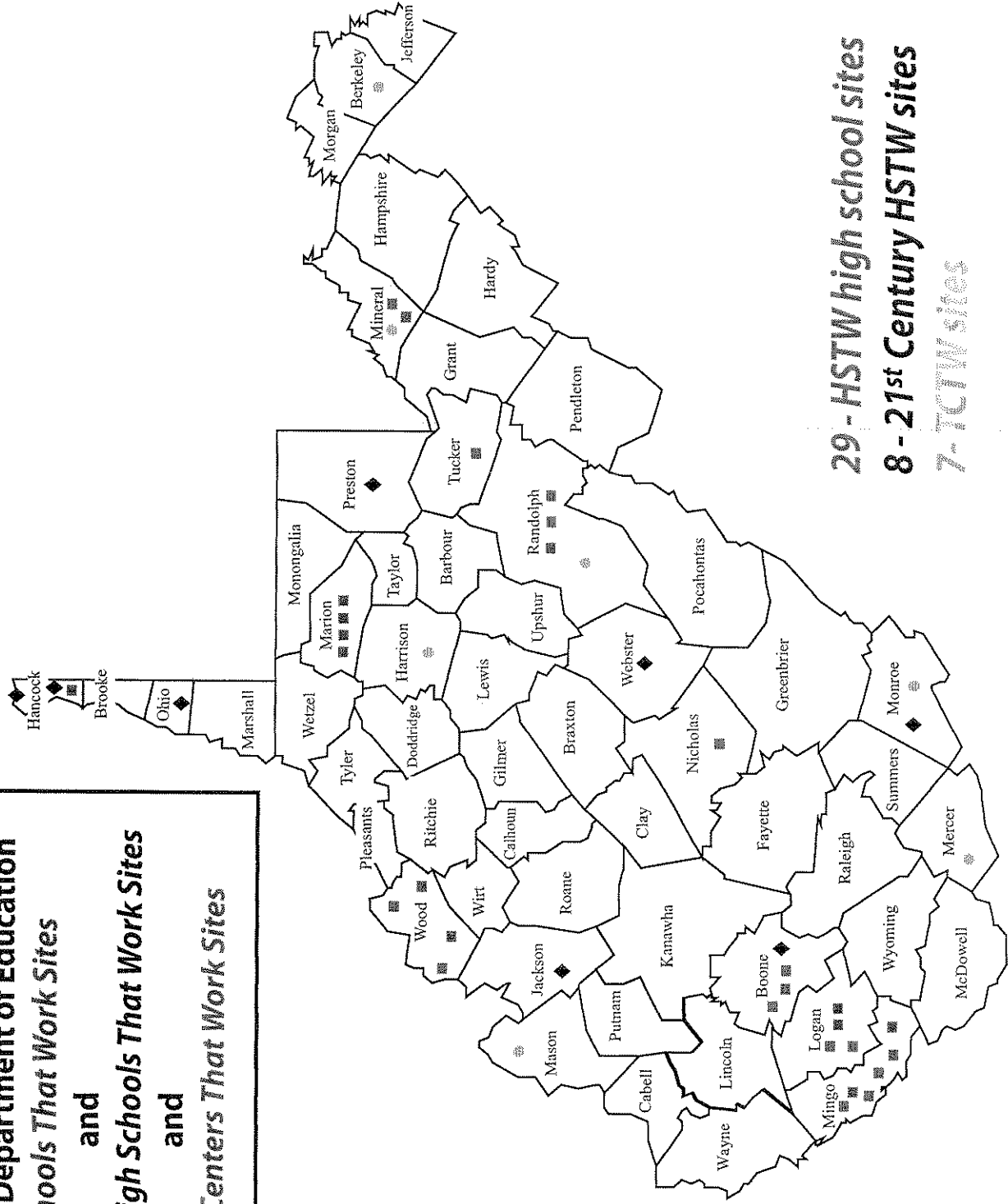

29 - HSTW high school sites
8 - 21st Century HSTW sites
7 - TCTW sites

Cedar Lakes Conference Center
Ripley, West Virginia
(304) 372-7860

Cedar Lakes Conference Center was established by an act of the Legislature in 1949 as the home for the West Virginia Future Farmers of America and the West Virginia Future Homemakers of America. Officially opened in 1955, the camp continues to grow each year. The name more commonly used is Cedar Lakes Conference Center, which more accurately reflects its growing role in the state.

Cedar Lakes has approximately 275 acres of land and 52 buildings to provide lodging, meeting and food facilities for over 700 people. Cedar Lakes was constructed primarily with contributions that were supplemented by state and federal funds. It is estimated that the total assets of Cedar Lakes Conference Center are valued at over \$15,000,000.

Over 182,500 people utilized Cedar Lakes' facilities last year. In 2010, the guest population represented all 55 states, the District of Columbia and many foreign countries. Cedar Lakes offers an inspirational retreat setting for business, education and recreation. The facilities are adaptable to meet the needs of corporate, civic, church, camp, family, social and government groups.

Cedar Lakes has dedicated itself to serving the youth of West Virginia by providing an affordable conference center where youth can meet and be housed while developing their leadership skills. In addition to the FFA and FCCLA, Cedar Lakes provides facilities to other organizations such as the Distributive Education Clubs of America (DECA), Technology Student Association (TSA) many other school sponsored activities, including 24 high school bands during the summer.

The 6th Annual Winterfest Activities and Light Show drew over 30,200 people through the center during the end of November through the end of December 2009. The total value of displays, grants and cash donated exceeds \$585,000. Career and Technical students from Mingo County, Roane-Jackson Technical Center, and Mason County won awards in the 2009 Winterfest Light Competition.

Of major cultural importance, Cedar Lakes Craft Center offers a variety of weekend and week long craft classes along with nationally recognized Elderhostel workshops. Cedar Lakes is also home to the Mountain State Art & Craft Fair. The 2009 Fair drew over 16,000 visitors who purchased \$565,000 from 150+ crafters and artisans. The Fair adds over one million dollars annually to the economy of West Virginia.

GLOBAL21

Students deserve it • The world demands it



Jorea M. Marple, Ed.D.
State Superintendent of Schools